

up

Universitatea
Politehnica
din Timișoara

Research Report 2012

**Research
Annual
Report**

Politehnica
University
of Timișoara

2012

Research Report 2012

Research Report, 2012

Copyright © Editura Politehnică 2013

All rights reserved to *Politehnica University of Timisoara*.

No part of this booklet may be reproduced or transmitted in any form or by any means, electronic or mechanical, including photocopy, recording, or any information storage and retrieval system now known or to be invented, without permission in writing from the publisher, except by a reviewer who wishes to quote brief passages in connection with a review written for inclusion in a magazine, newspaper, or broadcast.

Editorial team

Editor:
Prof. Marius-Emil OTEȘTEANU, PhD

Co-Editors:
Iris MIHAI
Simina DĂRĂBANȚ

Layout & cover design: IDEAtm

Editura Politehnică
Bv. Republicii, nr. 9, 300159
Timișoara, România
Phone: +40 256 403823
Fax: +40 256 403021

ISSN 1841-2769

Research
Report 2012

**Research
Annual
Report**
Politehnica
University
of Timișoara
2012

Structure of the report

Introducing the Report	5
Research Centers.....	7
Projects supported by public funds.....	11
Projects supported by private funds.....	89
Patents.....	127
Doctor Honoris Causa and Honorary Professor	129
Habilitation Theses	131
PhD Theses	135
Scientific conferences and events	147
Scientific Journals.....	149
ISI Publications.....	151

Introducing the Report

Politehnica University of Timisoara (UPT) is more than a simple teaching institution, it stands as a bastion of knowledge, a university of advanced research and education, which undertakes with devotion its goal to fulfill the requirements for competences of the societal environment by ensuring superior professional training for students and graduates.

The present document gathers the main results obtained through the research activities carried out within the university, *Politehnica* being renowned as a remarkable actor on the stage of scientific research, both at national and international level. Our research activity is facilitated by the existence of twenty-five research centres specialized in fields that are capital for the sustainable development of any modern society. Each of these research centres brings together various prestigious researchers, whom, by their effort and vision, provide UPT with the incentives needed to contribute to the progress of our society.

Most of the research activity carried out by our institution is financed through external sources, obtained either from national and international calls for projects, or through agreements with private companies. This represents a confirmation of the superior quality of the research, but also of the prestige and professional deontology of the researchers affiliated to our institution. *Politehnica's* reputation as an institution of advanced research is emphasized also by the patents obtained by its researchers, by the medals and prizes obtained in both national and international competitions, and by the collaborations with important research centres and institutes from Romania and from abroad.

Each year, we select the most talented young researchers for our doctoral school, providing them with the opportunity to transform their knowledge and ideas into the innovations of tomorrow. Many of them take part in peer learning programs consolidating the relationship between our university and similar partner institutions. They strive for becoming doctors in science and for making the world a better place.

This report is divided into ten sections, each one presenting a specific component of the research activity performed within the institution. Therefore, we will start by presenting the research infrastructure, comprising the twenty-five research centres hosted by the university. The order in which they are presented is given by the research fields.

The second and third sections include the research projects implemented by the university. The second section includes the projects supported by public funds, both national and international, while the third one includes the projects supported by private funds awarded by companies. For the purposes of this report, we have chosen the most relevant projects for our research capacity, encompassing 42 public funded projects and 36 private funded ones. Within each section, the projects are arranged by research fields.

In 2012 our institution was awarded five patents, having also submitted applications for another seven. Besides these twelve patents, some of our researchers have been nominated inventors as part of research projects carried out within other institutions and for which there have been submitted applications for patents. All these will be presented in the fourth section.

The fifth section presents two of our honorary members, one that has been awarded the *Professor Honoris Causa* recognition and one that has become *Honorary Professor*.

Section six and seven include habilitation theses and PhD theses. In 2012, four of our colleagues became habilitated, while 109 of our PhD research students became doctors.

Section eight presents an overview of the most relevant scientific conferences and events that brought together professionals from Romania and from abroad, hosting and encouraging the dialogue, exchange of ideas and the opportunity for new collaborations.

The ninth section gathers the scientific journals that have been edited by our institution. This category includes 12 journals specialized in various fields like computer science, chemistry and environmental engineering, electronics and communications, electrical engineering, hydrotechnics, physical education and sport, modern languages etc.

And, finally, the tenth section includes a bibliographic list of the ISI publications that were realized in 2012, comprising the results obtained by our researchers in several fields, papers that obtained recognition from some of the most prestigious journals, both from Romania and from abroad.

Through research we generate ideas, through ideas we generate innovation and through innovation we contribute to the improvement of the quality of life; this is why research is our priority.



Research Centre for Computers and Information Technology

Director: prof. Crețu Vladimir-Ioan
Contact: vladimir.cretu@cs.upt.ro, <http://www.cs.upt.ro/~vcretu>
Research projects under implementation can be found at pages: 11-16; 89;



Research Centre for Automatic Systems Engineering

Director: prof. Precup Radu – Emil
Contact: radu.precup@aut.upt.ro
<http://www.aut.upt.ro/centru-cercetare>
Research projects under implementation can be found at pages: 17-22;

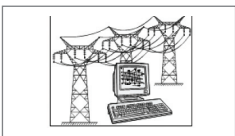

Research Centre for Power Systems Analysis and Optimization

Director: prof. Kilyeni Ștefan
Contact: stefan.kilyeni@et.upt.ro
Research projects under implementation can be found at pages: 23-26; 90-91;



Research Centre for Smart Energy Conversion and Storage

Director: prof. Muntean Nicolae
Contact: nicolae.muntean@et.upt.ro
Research projects under implementation can be found at pages: 29-30; 92;



Research Centre for Intelligent Electronic Systems

Director: prof. Oteșteanu Marius
Contact: marius.otesteanu@etc.upt.ro
<http://www.ccesi.etc.upt.ro/index.php/ro>
Research projects under implementation can be found at pages: 94-95;



Research Centre for Intelligent Signal Processing

Director: prof. Isar Alexandu
Contact: isar@etc.upt.ro, <http://www.tc.etc.upt.ro/isprc>
Research projects under implementation can be found at pages: 31-34;



Research Centre for Multimedia

Director: prof. VasIU Radu
Contact: radu.vasiu@etc.upt.ro, <http://www.cm.upt.ro>



Research Centre for Environmental Science and Engineering

Director: prof. Pode Rodica
Contact: rodica.pode@chim.upt.ro
http://www.chim.upt.ro/Facultatea-de-Chimie-Industrial-a-si-Ingineria-Mediului-Centru_GF.html
Research projects under implementation can be found at pages: 35-40; 96;



Research Centre for Inorganic Materials and Alternative Energies

Director: prof. Lazău Ioan

Contact: ioan.lazau@chim.upt.ro, http://www.chim.upt.ro/Facultatea-de-Chimie-Industriala-si-Ingineria-Mediului-Centru_Zx.html



Research Centre for Organic, Macromolecular and Natural Compounds' Chemistry and Engineering

Director: prof. Davidescu Corneliu

Contact: corneliu.davidescu@chim.upt.ro,
http://www.chim.upt.ro/Facultatea-de-Chimie-Industriala-si-Ingineria-Mediului-Centru_VT.html

Research projects under implementation can be found at pages: 41-42; 97;



Research Centre for Mechanics of Materials and Structural Safety

Director: prof. Dubină Dan

Contact: dan.dubina@ct.upt.ro

Research projects under implementation can be found at pages: 45-54; 57-58; 83-84;



Research Centre for Hidrotechnics

Director: prof. Man Teodor Eugen

Contact: eugen@zavoi.ro, <http://www.ct.upt.ro/centre/cchpm.htm>

Research projects under implementation can be found at page: 100;

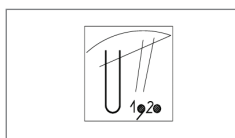

Research Centre for Building Services

Director: prof. Borza Ioan

Contact: ioan.borza@ct.upt.ro



Research Centre for Retrofitting of Constructions

Director: prof. Stoian Valeriu

Contact: valeriu.stoian@ct.upt.ro <http://www.ct.upt.ro/centre/reco.htm>

Research projects under implementation can be found at pages: 43-44; 55-56; 99;



Research Centre for Construction and Transportation Substructures

Director: prof. Marin Marin

Contact: marin.marin@ct.upt.ro



Research Centre for Mechatronics and Robotics

Director: prof. Maniu Inocențiu

Contact: inocentiu.maniu@mec.upt.ro

Research projects under implementation can be found at pages: 59-60;



Research Centre for Medical Engineering

Director: prof. Toth-Tașcău Mirela

Contact: mirela@mec.upt.ro, <http://cmpicsu.upt.ro>

Research projects under implementation can be found at pages: 61-62;



Research Centre for Integrated Engineering

Director: prof. Drăghici George

Contact: gdraghici@eng.upt.ro

Research projects under implementation can be found at pages: 63-64; 104;



Research Centre for Processing and Characterization of Advanced Materials

Director: prof. Șerban Viorel-Aurel

Contact: serban@mec.upt.ro, <http://eng.upt.ro/ccpcma>

Research projects under implementation can be found at pages: 65-70; 101-103; 105-107;



Research Centre for Complex Fluid Systems Engineering

Director: prof. Susan-Resiga Romeo

Contact: resiga@mh.mec.upt.ro, <http://mh.mec.upt.ro/cnisfc>

Research projects under implementation can be found at pages: 71-72; 121;



Research Centre for Thermal Machines and Equipments, Transportation and Environmental Pollution Control

Director: prof. Ionel Ioana

Contact: ioana.ionel@mec.upt.ro

Research projects under implementation can be found at pages: 73-80; 108-120;



Research Centre for Engineering and Management

Director: prof. Izvercianu Monica

Contact: monica.izvercianu@mpt.upt.ro

<http://www.mpt.upt.ro/pag/centru%20cercetare.html>

Research projects under implementation can be found at pages: 81-82; 122-123;



Research Centre for Urban Planning

Director: prof. Radoslav Radu

Contact: raduradoslav@gmail.com <http://ccddt.blogspot.ro>

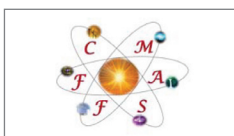

Research Centre for Advanced Study Methods for Physical Phenomena

Director: prof. Toader Dumitru

Contact: dumitru.toader@et.upt.ro

Research projects under implementation can be found at pages: 27-28;



Research Institute for Renewable Energy

Contact: www.icer.ro

Field	Total number of projects	Source of financing	Number of projects
Computers and Information Technology	4	Structural Funds*	1
		Cross-border Cooperation HU-RO	1
		National Funds**	2
Systems Engineering	3	National Funds	3
Energetic Engineering	3	National Funds	3
Electrical Engineering	1	National Funds	1
Electronics and International Telecommunication Engineering	2	International Programs***	1
		National Funds	1
Chemistry	3	National Funds	3
Chemical Engineering	2	National Funds	1
		Cross-border Cooperation HU-RO	1
Civil Engineering	7	International Programs	3
		Cross-border Cooperation HU-RO	1
		National Funds	3
Industrial Engineering	3	International Programs	2
		National Funds	1
Materials Engineering	4	National Funds	4
Mechanical Engineering	7	International Programs	2
		Cross-border Cooperation HU-RO	2
		National Funds	3
Management and Engineering	1	National Funds	1
Architecture and urbanism	1	National Funds	1
Mathematics	1	National Funds	1

* Structural Funds - European Regional Development Fund, European Social Fund and the Romanian National Authority for Scientific Research

** National Funds – funds awarded by the Romanian govern through UEFISCDI

***International Programs – EU 7th Framework Program, Research Fund for Coal and Steel or the Information and Communication Technologies Policy Support Program

Goal of the project: Research of the various types of advanced software applications for state-of-the-art multi-core systems, with focus on the field of multimedia on mobile phones, and development of appropriate semi-automatic tools and processes to increase the productivity of such applications.

Short description of the project: The field of mobile devices and applications is currently of key interest for the scientific and industrial communities in the world. In this field, Movidius Ltd. Ireland and its branch in Timisoara have been developing a state-of-the-art multi-core processing platform for advanced multimedia applications. For instance, this architecture is able to perform complex real-time image and video processing. This project aims to study and implement the necessary software development processes and tools, to cover and optimize all the layers involved in the production of advanced multimedia applications for mobile devices, from design to operation and testing.

Project implemented by: Research and development partnership between Movidius SRL. and "Politehnica" University of Timisoara.

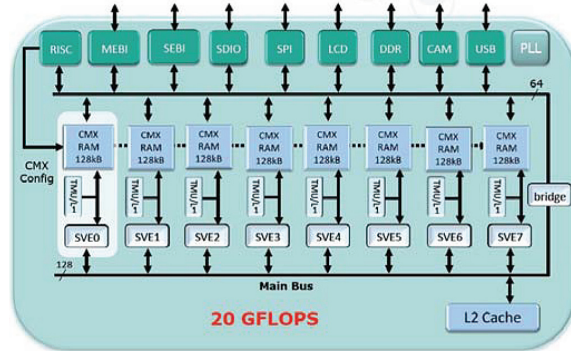
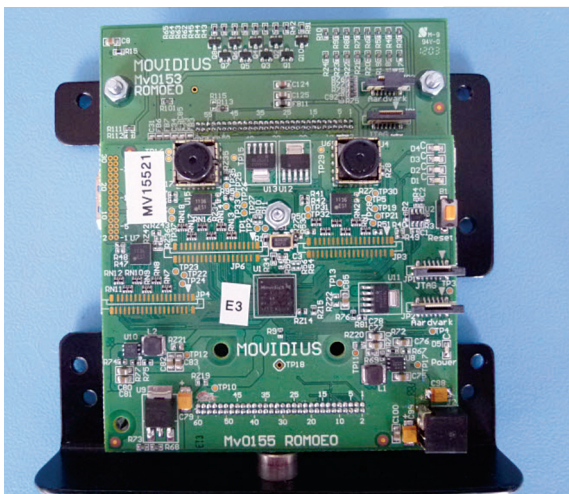

Implementation period:
04.06.2010 - 03.06.2012

Main activities:

- Analysis of state of the art applications for the next generation of mobile devices;
- Development of a hardware accelerator architecture model for advanced multimedia and mobile applications;
- Tools for low-level software development and automatic code generation on the Movidius multi-core execution platforms;
- Tool for automatic partitioning of advanced application code on multi-core architectures;
- VLIW compiler for the Movidius devices.

Results:

- Models and implementations of hardware interface modules in a multiprocessor system-on-chip simulator;
- Specification and requirements of a real-time multiprocessor operating system for multimedia applications;
- *moviTest* automatic application validation environment;
- *moviOS* multi-core real-time and parallel operating system;
- *moviSim* multi-core simulator;
- *moviAsm* assembler for the Sabre processor;

"Computer Science is no more about computers than astronomy is about telescopes"

Edsger Wybe DIJKSTRA

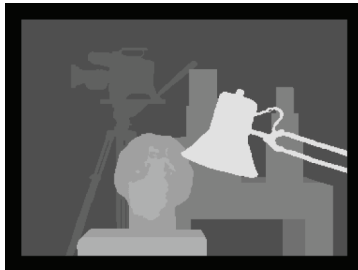

- *moviDebug* application loader and debugger for the Movidius execution platforms;
- *moviCompile* C and C++ compiler;
- 2 patent applications filed at the OSIM and WIPO patent offices;
- 9 scientific papers published at international conferences and symposiums;
- 11 new jobs created for highly-qualified personnel.

Fields of interest: Multimedia, mobile applications, multi-core architectures, digital image and video processing, real-time systems, parallel processing, compilers and software tools.

Financed through/by: European Regional Development Fund, European Social Fund and the Romanian National Authority for Scientific Research, ANCS. Total value: ~506400 EUR.

Research team:

Project management: Dr. eng. Valentin Muresan (Movidius, project director), A/Prof. Dr. eng. Mihai Micea (UPT, project manager), eng. Cristian Cuna (Movidius, tools team leader);

Scientific council (UPT): Prof. Dr. eng. Vladimir Cretu, Prof. Dr. eng. Mircea Vladutiu, Prof. Dr. eng. Horia Ciocarlie, A/Prof. Dr. eng. Doru Todinca, Lect. Dr. eng. Mihai Udrescu-Milosav, Lect. Dr. eng. Lucian Prodan;

R&D team (UPT): Dr. eng. Alexandru Amaricai- Boncalo, Dr. eng. Oana Amaricai-Boncalo, Dr. eng. Georgiana Macariu, Gheorghe Guran, Andrei Tanase, Valentin Stangaciu, Cristina Stangaciu, Luminita Daraban, Cristiana Crisan, Caius Brindescu, Catalin Mihai, Raluca Veleanu, Camelia Valuch, Teodor Tite, Ancuta Ivascu, Ivan Velciov, Adelina Vig, Alexandru Dura, Demis Diaconescu, Madalina Ghidovit, Marius Cosma;

Support team (UPT): ec. Florian Miclea, eng. Dorina Ruset, eng. Claudia Micea, eng. Mihaela Ciuleanu, Lidia Jebelean, Alina Mondoc, Alina Atanasescu, Nicolina Adamescu.

Research centre: Research Center for Computers and Information Technology, "Politehnica" University of Timisoara

Aplicability and transferability of the results: All the results have been directly assimilated by Movidius. Patent application "Method and System for Detecting Frame Compatible 3D Content" filed at national (OSIM, no. A00376/05.2012) and international (WIPO, no. PCT/RO2012/000010/05.2012) patent offices.

Contact information:

Project Website: <http://www.falx-daciae.ro/>

SC. Movidius SRL.

2/A, Paris Str., Room 01, 300003, Timisoara

Tel: +40 356 170271

Fax: +40 356 170272

mihaela.tunsoiu@movidius.com

Assoc. Prof. Dr. eng. Mihai V. Micea, Dept. of Computer and Software Engineering DSPLabs - Digital Signal Processing Laboratories

"Politehnica" University of Timisoara 2, Vasile Parvan Blvd., 300223, Timisoara

Tel: +40 256 403271

E-mail: mihai.micea@cs.upt.ro

Web: <http://dsplabs.cs.upt.ro/~micha/>

"Computer Science is no more about computers than astronomy is about telescopes"

Edsger Wybe DIJKSTRA

Goal of the project: The project implementation is carried out on two main directions: (1) to strengthen the education process of both universities in the fields of image processing, mobile applications development and data mining and (2) to propose and develop an image based recommendation solution running on mobile devices for educational purposes within the border region.

Short description of the project: The educational process is developed by an extensive exchange of know-how and by joint development of a real life mobile client-server application. The knowledge is transferred between universities and also between experts and students involved in the project development. Therefore a number of joint seminars have been proposed and delivered to the team of students. The development process of a mobile application involved the students in lifecycle of a mobile application.

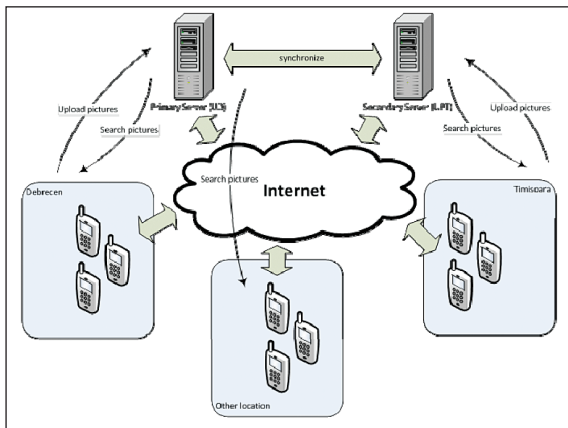

Project implemented by: Mobile Computing, Sensors Network and Embedded Systems Laboratory and Real-Time Systems, Robotics and Digital Signal Processing Laboratory

Implementation period:
01.01.2012-31.01.2013

Main activities: Development activities address three research domains: (1) image processing and image retrieval, (2) data mining algorithms applied to images and (3) mobile applications development using augmented reality and user context detection. Using the theoretical and practical knowledge transferred to the participating students, an image-based recommendation solution has been developed.

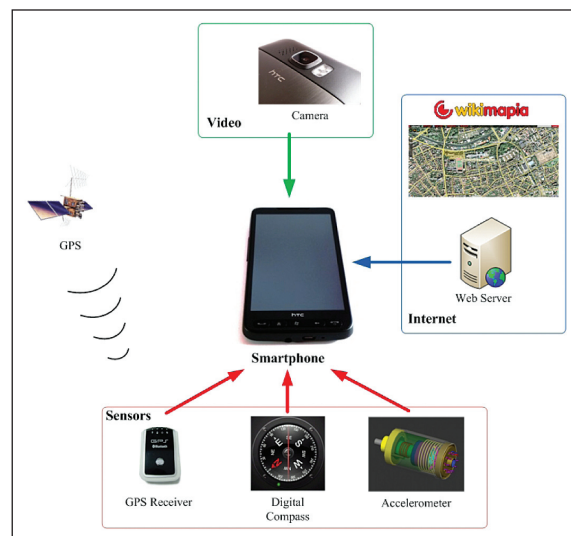

The recommendation solution is based on clientserver architecture. The client side is running on the mobile devices and the server side is deployed within the server infrastructure. Mobile client application takes the input from the users as picture, then augments the picture with relevant information for data mining process and sends this information to the server component.

The user can add specific keywords to the taken pictures and sends them together with the other information. The server stores the received images together with their associated augmented information and applies the data mining algorithms.

"Innovation distinguishes between a leader and a follower."

Steve Jobs

When the user searches for specific keywords, the server responds with relevant information and associated images stored in the database. The retrieved information is displayed on the mobile screen and the user can select and view the requested data.

Results: This project addresses the main aspects of the smart growth strategy in Europe 2020 program: education, research/innovation and digital society. We try to use our common research experience on mobile devices, image recognition and data mining to introduce and adapt educational process to the modern mobile digital society. We aim this targeting two directions: (1) to integrate an already existing resource – mobile devices – in the educational process; (2) to increase the attractiveness of programs of study by using this infrastructure and based on a stronger orientation to labor market needs.

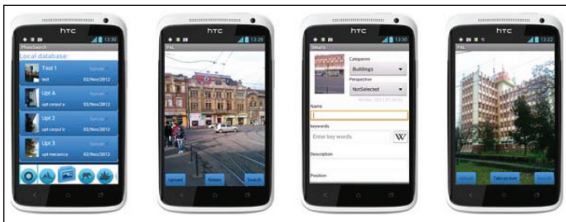

Fields of interest: image processing and image retrieval, data mining algorithms applied to images and mobile applications development.

Financed through/by: The Romanian partner of the project was funded by European Regional Development Fund through Hungary-Romania Cross-Border Co-operation Programme 2007- 2013 (www.huro-cbc.eu) with 89,202 EUR as follows 75,822 EUR ERDF contribution, 11,596 EUR national contribution and 1,784 EUR own contribution.

Research team: University of Debrecen (Lead Partner) and Politehnica University of Timisoara - Assoc. Prof. Dr. Eng. Marius Marcu – teaching expert and principal investigator; Assoc. Prof. Dr. Eng. Horatiu Moldovan, Prof. Dr. Eng. Vasile Gui – teaching expert; Prof. Dr. Eng. Mircea Popa – teaching expert; Assoc. Prof. Dr. Eng. Mihai Micea – teaching expert; Assist. Prof. Dr. Eng. Alexandru Amaricai-Boncalo – software expert; Assist. Prof. Dr. Eng. Razvan Ciorga – software expert; As. drd. Eng. Dan Chiciudean – software expert; Eng. Mihaela Ciuleanu – project assistant; Ec. Marinela Balut - financial assistant; Eng. Dan Cuc (MS student); Eng. Silvia Martin (MS student); Andrei Sirbu (student IV CTI); Georgia Papp (student III CTI); Cornel Isbiceanu (student III CTI); Robert Raut (student III CTI).

Research centre: Research Centre for Computers and Information Technology

Applicability and transferability of the results: The seminars developed during the project implementation take part of the curricula offer of Computer and Information Technology Department. The mobile recommendation application is available for free on Google Play market.

Contact information:

“Politehnica” University of Timisoara
Automation and Computers Faculty
Assoc. Prof. Dr. Eng. Marius Marcu
Address: 2 V. Parvan Blv., 300223
Tel. 0256-403263,
Fax. 0256-403214
E-mail.: marius.marcu@cs.upt.ro
Web page: www.mobileassistant.ro
Google Play: TravelPAL



“Innovation distinguishes between a leader and a follower.”

Steve Jobs

Goal of the project:

This project proposes to develop dedicated floating point architectures on FPGAs to suit the growing demand of graphic application on these platforms.

Short description of the project:

Recent studies indicate that FPGAs provide better watts/flops performance compared to graphical processing units (GPUs). Adding features such as flexibility and high degree of parallelism makes suitable candidates for implementing graphical accelerators on future embedded systems. The major novelty of the proposal consists in the design of high performance FP units using an efficient exploitation of the FPGA arithmetic resources, such as the embedded multipliers or block RAM modules. Thus, dedicated arithmetic units for reconfigurable devices will be provided. Two types of FP operations are targeted: multiply and multiply-accumulate architectures (used for matrix products, vector and matrix products and dot products) and combined division and square roots (used for matrix inversions, Euclidean distance computations, etc). These units will be the backbone of dedicated hardware accelerators (for vertex, geometry and pixel shader operations) for these types of applications.

Project implemented by:

University Politehnica of Timisoara,
Computer Engineering Department

Implementation period:

October 2011 - October 2014

Aplicability and transferability of the results:

A major goal of the research is represented by providing adequate floating point support for Open Hardware initiatives. We intend to add high performance floating point functionality to open source graphics accelerators, such as the one provided for OpenRISC based platforms.

Main activities:

1. Development of FP multiply and MAF architectures for FPGA. FP multiply and MAF operations are especially important in multiplications between vector and matrices.
2. Development of FP combined division and square root for FPGA.
3. Development of hardware accelerators for graphic operations and applications implementation based on designed hardware.

Results: We have provided floating point units for very high radix division and square root. These units have the smallest DSP count for multiplication based division/square root methods. On the other hand, we have researched floating point units for multiplication and multiply-add fused operations. We have provided a hybrid integer-floating point multiplier and a high performance floating point multiply-add fused which relies on architectures of the DSP blocks in modern FPGAs. Our research has resulted in one ISI rated journal paper and four published or accepted conferences.

Research centre: Research Centre for Computers and Information Technology.

Financed through/by: CNCS PNII Human Resources - Young Researchers

Research team: Dr. Alexandru Amaricai - Principal Investigator, Assoc. Prof. Marius Marcu, Prof. Mircea Popa, Dan Chiciudean, Ovidiu Sicoe.

Contact information:

Dr. Alexandru Amaricai
Email: alexandru.amaricai@cs.upt.ro
Telephone: +40256403272
Web: www.cs.upt.ro/~amaricai/flag.html

"People who are really serious about software should make their own hardware."

Alan Kay

Goal of the project:

The GEMSCLAIM project aims at introducing novel approaches for reducing the “greed for energy” of modern battery powered systems, thereby improving the user experience and enabling new opportunities for mobile computing.

Short description of the project: Mobile terminals and consumer devices are among the fastest growing markets in computing. In the long term, further growth is endangered by the “power/ energy wall”. The purpose of GEMSCLAIM is to explore new techniques in energy optimization via an interdisciplinary vertical approach: a novel combined optimization across the major HW/SW system layers (compiler/OS/ HW platform).

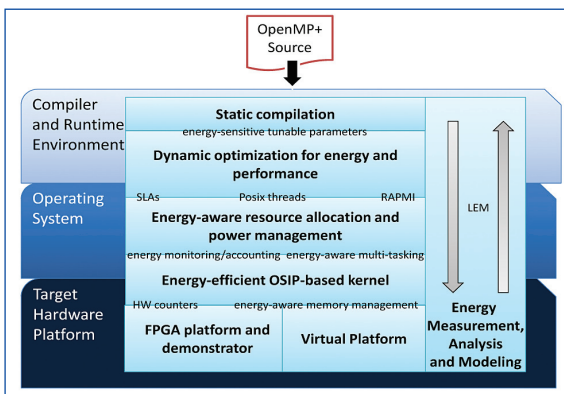

Project implemented by: Mobile Computing, Sensors Network and Embedded Systems Research Laboratory

Implementation period:
01.09.2012-31.08.2015

Main activities: In a world of de-facto standards as well as huge amounts of legacy HW and SW, it is very difficult to achieve real breakthrough in system-wide energy savings beyond fragmented point solutions, e.g. at the HW or OS level.

GEMSCLAIM’s mission is to overcome this hurdle by a novel cross layer energy optimization approach that combines the following major research activities: (1) Development of an energy-aware optimizing and parallelizing compiler; (2) Component aware energy-efficient operating system and (3) Customizable HW modelling with energy monitoring facilities.

Results: (1) The Virtual Prototype of the experimental HW/OS/Compiler platform and (2) FPGA Prototype experimental HW/ OS/Compiler with Power Monitors.

Fields of interest: Heterogenous multi-core embedded systems

Financed through/by:
CHIST-ERA partnership projects, PNII-IDEI – 1/CHIST-ERA/01.10.2012

Research team: Innsbruck University (LP), Queen’s University Belfast, RWTH Aachen University, Politehnica University of Timisoara:

- Assoc. Prof. Marius Marcu (PI)
- Dr. Oana Boncalo
- Dr. Sebastian Fuicu
- Dr. Gabriel Garban
- Dr. Alexandru Amaricai
- Dr. Razvan Bogdan
- Eng. Lucian Bara

Research centre: Research Centre for Computers and Information Technology

Aplicability and transferability of the results:
Mobile HW/OS/SW solutions development.

Contact information:
Marius MARCU, 2 V. Parvan Blv., Timisoara
E-mail.: marius.marcu@cs.upt.ro

“People who are really serious about software should make their own hardware.”

Goal of the project:

Enhance the existing techniques and develop new techniques dedicated to the improvement of control system performance using experimental data.

Short description of the project:

The project aims to:

- Enhance and develop data-based (data-driven) techniques and algorithms for improving control system performances using experimental data.
- Enhance and develop nature-inspired algorithms in optimization of control system performance.
- Develop optical character recognition (OCR) applications.
- Develop new fuzzy control solutions for a wide range of industrial processes.

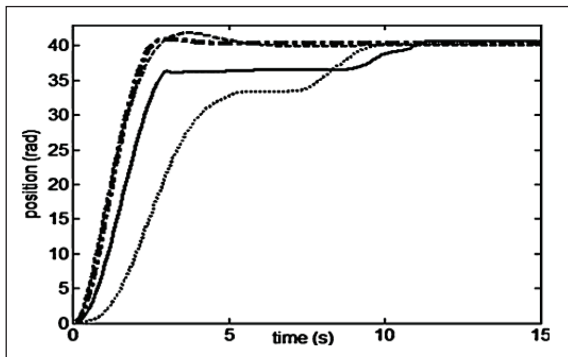

Application of stable Iterative Correlation-based Tuning (ICbT) to servo systems. An experiment-based approach to Reference Trajectory Tracking optimal control problem.

Validation of iterative techniques on laboratory equipment such as: liquid level control, motion control systems with motor actuation (speed and position control, inverted pendulum).

Enhancement of control systems performance by fuzzy control and IFT.

Enhancement of existing nature-inspired algorithms such as Gravitational Search Algorithm (GSA) and Charged System Search (CSS).

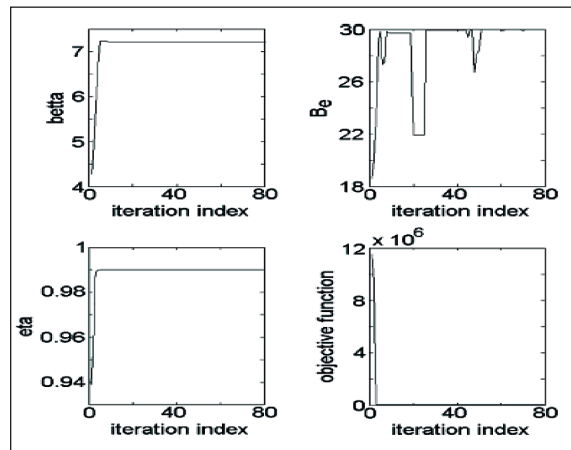

Project implemented by: Department of Automation and Applied Informatics. <http://www.aut.upt.ro/~rprecupgrant2011.html>

Implementation period: 2011-2014.

Main activities: Application of Iterative Feedback Tuning (IFT) and Simultaneous Perturbation Stochastic Approximation (SPSA) to state-feedback optimal control with Kalman filter state observers.

PI and fuzzy controller tuning to ensure a reduced sensitivity with respect to the parametric variations of processes.

Enhancement of the training algorithm of Convolutional Neural Networks using a mixed approach of Back-Propagation and Gravitational Search Algorithm.

Development of telesurgical applications and control of telerobots in space medicine, Control of nonlinear discrete-time MIMO systems.

"What we find changes who we become."

Peter Morville

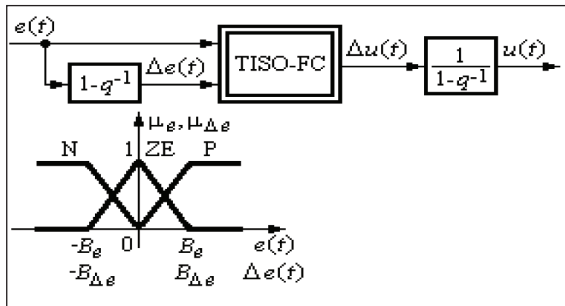

Results:

- 5 papers (ISI) published in journals with impact factors in 2012 (out of 15 reported for the research contract in 2012).
- 2 papers published in conference proceedings (ISI Proceedings).
- 2 book chapters published in Springer-Verlag volumes.
- 4 papers published in conference proceedings indexed by international databases.
- 17 independent citations received in 2012 for the papers reported in the research contract in 2011 and 2012.

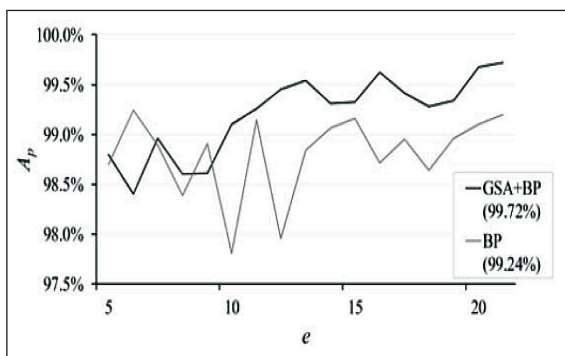

Fields of interest: control systems, optimization, motion control, robotics, nature-inspired algorithms, optical character recognition, fuzzy control.

Financed through/by:

Executive Agency for Higher Education, Research, Development and Innovation Funding – UEFISCDI, Bucharest, Romania.

Research team:

Prof. Dr. Eng. Radu-Emil Precup - director, principal investigator, Prof. Dr. Eng. StefanPreitl - senior staff member, Assoc. Prof. Dr. Eng. Florin Drăgan - senior staff member, Assist. Prof. Dr. Eng. Daniel Iercan - post doc, Assist. Prof. Dr. Eng. Mircea-Bogdan Rădac - post doc, Assist. Prof. Dr. Eng. Claudia-Adina Dragoș -post doc, M.Sc. Dipl. Eng. Alexandra-Iulia Stînean - Ph.D. student, M.Sc. Dipl. Eng. Lucian-Ovidiu Fedorovici - Ph.D. student.

Research centre: Research Centre for Automatic Systems Engineering (CCISA).

Applicability and transferability of the results:

Control systems with a reduced parametric sensitivity, tools for the computer-aided design of controllers, computer-aided techniques in iterative data-based control, nature-inspired optimization algorithms in control design and image processing, tools for the systematic development of fuzzy control systems.

Contact information:

Prof. Dr. Eng. Radu-Emil Precup - Director of the CCISA Research Centre, "Politehnica" University of Timișoara, Department of Automation and Applied Informatics
Address: Bd. V. Pârvan 2, 300223 Timișoara, Romania

Tel.: +40-256403229

Fax: +40-256403214

E-mail: radu.precup@aut.upt.ro

"What we find changes who we become."

Goal of the project: Development of control structures and algorithms and optimal tuning of fuzzy models for a wide range of industrial processes, mechatronics, mobile robots and automotive applications.

Short description of the project:

The project aims at:

- Advanced control structures for automotive and mechatronics applications.
- Improvement and development of new Takagi Sugeno (T-S) fuzzy models and control solutions for a wide range of industrial processes.
- Optimal tuning of fuzzy models for automotive and mechatronics applications.
- Improvement and development of control algorithms for mobile robots.

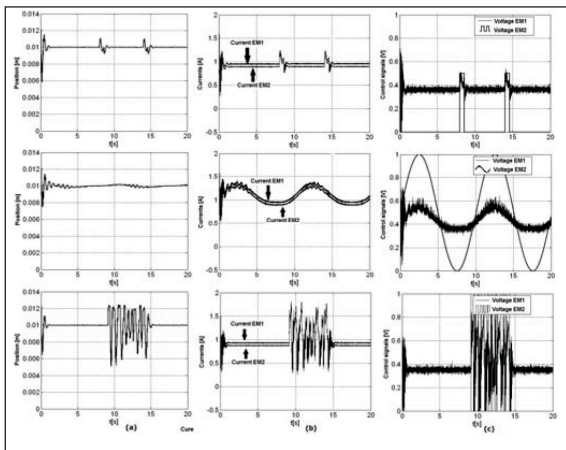

Project implemented by:

- Department of Automation and Applied Informatics as the P1 partner, coordinator: "Gheorghe Asachi"
 - Technical University of Iasi (TUIASI), P2 partner:
 - S.C. ROMUS Trading & Development SRL, director: Prof. Dr. Eng. Silvia Curteanu (TUIASI).
- http://www.romus.com/proiecte/asachi/pages/pages/phpsite_index.php

Implementation period: 2012-2015.

Main activities: Design of low-cost T-S state feedback fuzzy controllers for the position control of a class of nonlinear servo systems.

Sensitivity analysis with respect to the process parametric variations in the low-cost controller designs for vehicle power train systems with spark-ignition engine and continuously variable transmission.

Modelling, simulation, analysis and design of linear, fuzzy and variable structure control solutions for direct current electric drive systems with continuously variable reference input, variable moment of inertia and variable load disturbance input, applicable to rolling mills and to strip winding systems.

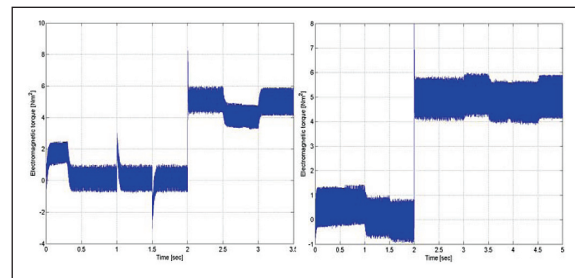

Development and experimental validation of simple T-S fuzzy models for several processes in automotive and mechatronics: anti-lock braking systems, nonlinear DC drive servo systems, magnetic levitation systems, electromagnetic actuated clutch systems, inverted pendulums.

Development of two-degree-of-freedom linear and fuzzy controllers, of hybrid T-S fuzzy controllers, of hybrid PI neuro-fuzzy controllers and of adaptive sliding mode fuzzy controllers for speed and position control of brushless DC drives with variable parameters.

"Research consists in seeing what everyone else has seen, but thinking what no one else has thought."

Albert Szent-Gyorgyi

Optimal tuning of parameters of T-S fuzzy models using nature-inspired algorithms: simulated annealing, particle swarm optimization, gravitational search algorithms.

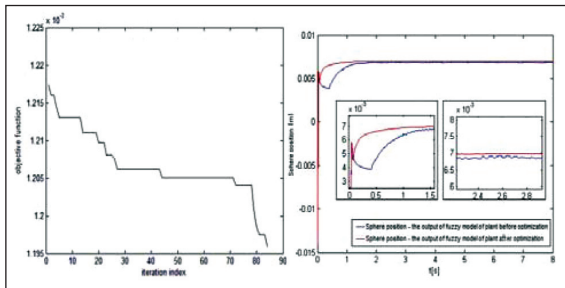

Continuous development of the nRobotic platform in the framework of path planning and collision avoidance for mobile robots in missions.

Derivation and testing of a new path planning algorithm as an extension of the vector field histogram algorithm.

Results:

- 4 papers published in ISI journals with impact factors.
- 2 papers published in journals indexed by international databases.
- 13 papers published in conference proceedings indexed by international databases.
- more than 50 independent citations in 2012.

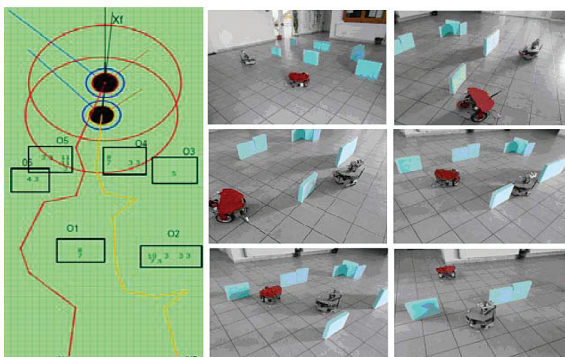

Fields of interest:

control algorithms, optimal tuning, fuzzy models, automotive, mechatronics, mobile robots, networked control systems, Programmable Logic Controllers, real-time programming, image processing.

Financed through/by:

Executive Agency for Higher Education, Research, Development and Innovation Funding (UEFISCDI), Bucharest, Romania.

Research team:

Prof. Dr. Eng. Radu-Emil Precup - director, Prof. Dr. Eng. Stefan Preitl, Prof. Dr. Eng. Ioan Filip, Assoc. Prof. Dr. Eng. Florin Drăgan, Assist. Prof. Dr. Eng. Adriana Albu, Assist. Prof. Dr. Eng. Ovidiu Baniaş, Assist. Prof. Dr. Eng. Daniel Iercan, Assist. Prof. Dr. Eng. Claudia-Adina Dragoş, Assist. Assist. Prof. Dr. Eng. Mircea-Bogdan Rădac, PhD student M.Sc. Eng. Alexandra-Lulia Stînean, PhD student M.Sc. Eng. Lucian-Ovidiu Fedorovici, PhD student M.Sc. Eng. Constantin Purcaru.

Research centre: Research Centre for AutomaticSystems Engineering (CCISA).

<http://www.aut.upt.ro/centrucercetare/index.EN.php>

Applicability and transferability of the results:

Nature-inspired optimization algorithms in modelling and control design, low-cost solutions for control problems in mechatronics, electrical drives, automotive and robotics, tools for the modelling, optimization and design of fuzzy control systems, real-time programming and operating systems for control and robotics.

Contact information:

Prof. Dr. Eng. Radu-Emil Precup - director of theCCISA Research Centre, "Politehnica" University of Timișoara, Department of Automation and Applied Informatics Bd. V. Pârvan 2, 300223 Timișoara, Romania Tel.: +40-256403229, Fax: +40-256403214 E-mail: radu.precup@aut.upt.ro

"Research consists in seeing what everyone else has seen, but thinking what no one else has thought."

Albert Szent-Gyorgyi

Goal of the project:

The project is focused on the research, development and testing of an intelligent and flexible (configurable) small scale power system based on integration of three renewable energy sources: wind, hydro, and solar (photovoltaic) power, adapted to the available resources in Romania, in various regions of the country, working independently or connected to the grid.

Short description of the project:

The project will cover the entire power conversion structure, including the design of adequate prime movers and new types of generators and power electronic converters, storage devices, power flow management system and load control.

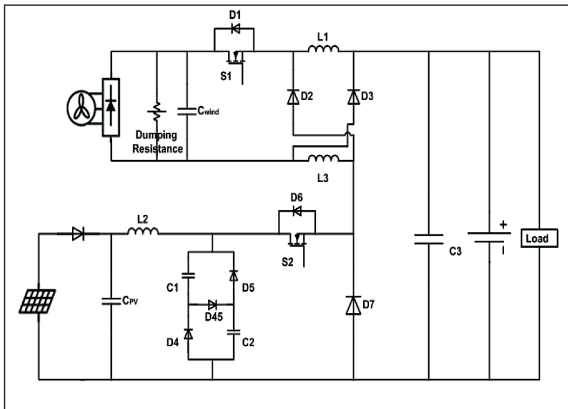

Some configurable structures (wind, micro-hydro and PV, all or a part of them, including their integration in a microgrid) will be proposed as experimental models, ready to be transferred to industry. There are proposed novelty elements regarding: low power wind turbine with integrated overspeed protection system, new generators configurations, and new topologies for power electronic converters

and microgrid structures, optimal local control strategies and intelligent power system management.

Project implemented by:

“Politehnica” University of Timisoara – Project coordinator
 Technical University of Cluj-Napoca – Project partner
 SC EETIM SA – Project partner

Implementation period: 2012 -2015

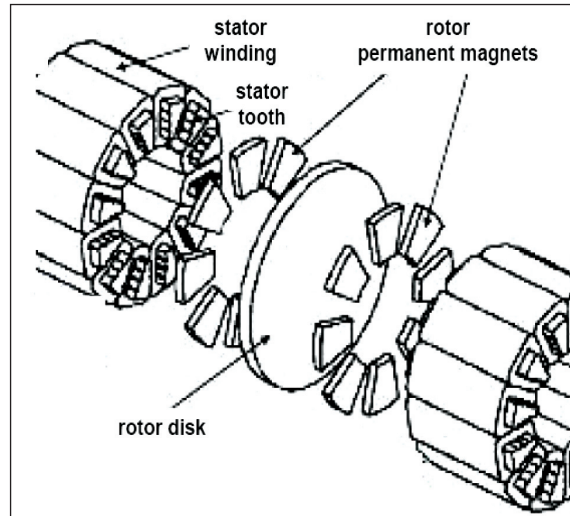

Main activities:

- Microgrid components modeling, simulation and design.
- Microgrid components manufacturing, individual testing and integration in the experimental setup.
- Design, implementation and validation of the control strategies for microgrid components.
- Design, implementation and validation of the microgrid control strategy.
- Results dissemination and know-how exchange.

“At every level the greatest obstacle to transforming the world is that we lack the clarity and imagination to conceive that it could be different”

Roberto Unger



Results:

- A new over-speed protection system for wind turbines.
- A new electrical reactive brushless dc generator with performances comparable with high energy PM generator, at low cost.
- A new RF-IPMSG with high efficiency, maintenance-free operation, and high controllability.
- A new AF-PMSG optimised for modular design. A new multiphase inverter with adequate control for the proposed generators.
- New multi-input dc-dc converters with high efficiency.
- High power tandem inverters for load management.
- Hardware and software package for power management, power flow control, individual converter control, and MPPT and other control strategies.
- Experimental microgrid system with integrated photovoltaic, wind and hydro generation.
- Technical papers will be published in top international journals and conference proceedings.

Research centre: Research Centre for Automatic Systems Engineering.

Financed through/by:

Joint Applied Research Projects-Partnership in S&T priority domains financed by the Executive Agency for Higher Education, Research, Development and Innovation Funding (UEFISCDI).

Research team:

UPT: Octavian Prostean, Nicolae Muntean, Nicolae Budisan, Ioan Filip, Mircea Barghazan, Gabriela Prostean, Stefan Kilyeni, Ilarie Bordeasu, Teodor Milos, Cristian Vasar, Lucian Tutelea, Cristian Lascu, Sorin Deaconu, Dan Ungureanu, Iosif Szeidert, Adrian Bej, Radu Boraci, Octavian Cornea, Ovidiu Tirian and Rodica Badarau



Applicability and transferability of the results:

All the research results are the property of the project coordinator and its partners.

Contact information:

Prof. eng. Octavian Prostean, PhD.
Tel: (+40) - (0) - 256 - 403.225
Fax: (+40) - (0) - 256 - 403.214
E-mail: octavian.prostean@aut.upt.ro

Goal of the project:

Developing the prototype of a high-power LED street light with superior technical performances and lower cost and developing a case with aesthetic and functional characteristics in order to be highlighted among other European producers.

Short description of the project:

This project started when the beneficiary, SC Mariomih SRL, intended to assimilate the prototype of a LED street light, with superior technical performances and lower cost compared with those of the competitors on the market.

Also, another aspect which concerned the research team was developing an esthetic and functional case for the street lamp which would consolidate its position among other European manufacturers.

This comes in a time when Chinese manufacturers monopolize the "Cobra" design and a new Romanian manufacturer – SC Electromax SRL – had to develop a case in shape of an A4 paper. So, the research team had to combine industrial with demonstrative research.

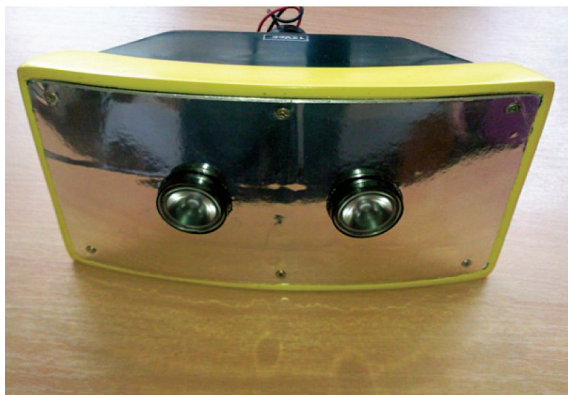

In terms of experimental industrial research, the research team tested for energy efficiency some of the best LEDs on market (Cree and Samsung). In terms of efficiency, the team turned to those LEDs which have an efficiency of 120-140 lm/W in order to have a higher grade of luminescence than other products at 40-50 absorbed Watts. So, in order to choose the LEDs the goal of the team was to reach the best ratio between the light intensity and the power consumption and also a wider light spreading angle to fulfill the minimal imposed standards.

This final task was completed both by the LED parameters provided by the manufacturer and the shape of the case.

The arc of circle model for the case - an atypical one – is certified by both OSIM (Romania) and OHIM (EU). This model was taken over by the beneficiary of the project, using the transfer of manufacturing license, for use in the future production department, where one of the models proposed by the research team will be produced.

Project implemented by:

SC MARIOMIH SRL

Main activities:

- developing the prototype of a high-power LED street light with superior technical performances and lower cost;
- choosing LEDs with a smaller ratio between the light beam intensity and power consumption, and also a large enough light scattering angle to fit into the minimal standards required by law;
- developing a case with superior aesthetic and functional characteristics.

"We cannot hold a torch to light another's path without brightening our own."

Ben Sweetland

Results:

Experimental models:

- Light bulb powered by a 12V and 1000 mA D.C. solar panel;
- Street lighting lamps for parks and parking lots fed by 12 V and 1000 mA D.C. solar panels;
- Ceiling light with 100 5mm LEDs;
- Street lighting lamp with 300 5mm LEDs;
- Street lighting lamp with 5 light bulbs in "Cobra" case, powered directly from 230 V mains;
- Street lighting lamps with MC-H chips and Samsung LEDs - powered directly from 230 V mains - or 494 lumens Cree LEDs;
- Highway lighting lamps equipped with 3 kits of 3000 lumens each.

Implementation period:

29.06.2012 - 04.12.2012

Fields of interest:

Energy and Environment

Financed through/by:

UEFISCDI – INNOVATION Program, Support Services for Innovation – Innovation Circles

Research team:

Flavius Dan Şurianu – Director, Aldo De Sabata, Mircea Nicoară, Ioan Silea, Daniel Dejica-Carţiş, Felix Traian Zamfir.

Research centre:

Research centre for Power Systems Analysis and Optimization.

Contact information:

Prof. Flavius Dan Şurianu, Ph.D.

2 Parvan Blvd., Room C112

Phone: 0256 403412

Email: flavius.surianu@et.upt.ro



*"We cannot hold a torch to light another's path
without brightening our own."*

Ben Sweetland

Goal of the project: The main objective of the project was to achieve the transfer of know-how from University to industry. With other words, the objective of the project was to develop a prototype for a voltage dip monitoring system designed within a postdoctoral research project.

Short description of the project:

The project was a joint venture between the University and industry. The idea of the project started from results obtained in a passed research project and the necessity of the implementing of these results in a voltage dip monitoring device.

The motivation of the project is due to the fact that in technical literature there are summarized the problems caused by a lack of power quality, stating that in Europe the costs consumer due to power quality problems is approximately 100 billion Euros, of which more than a half are due to voltage dips and short interruptions. In addition, the power quality monitoring devices currently available are made according to the existing international standards. These standards require identifying only two parameters of voltage dips, namely voltage amplitude and dip duration, which are reported to the acceptability curve CBEMA (Information Technology Industry Council). These conclusions are found in the technical documentation of the newest voltage quality monitoring devices. In addition these devices save data in files with special format (own), which involves the acquisition of file conversion programs.

The device was designed in order to be easily used at low voltage level from all the electricity consumers: industry and domestic. It means that is small enough as it can be installed together with the classical overcurrent protections.

Implementation period:
19.07.2012-18.12.2012

Project implemented by: Power Engineering Department from UPT in partnership with SC Rheal SRL Timisoara (SC Rheal is the beneficiary of the results)

Main activities: Starting from results of the postdoctoral project and considering the beneficiary's request, the hardware of the monitoring device was redesigned. The scope of redesigned was to implement the voltage dip monitoring device in a modular way. To achieve this criteria the printed circuit board was reduced using different techniques. First it was reduced the number of acquiring channels. Second it was used different techniques to reduce the dimensions of the printed circuit board. The minimum dimensions of the device were reached by handmade design assisted with computer of the printing circuit board.

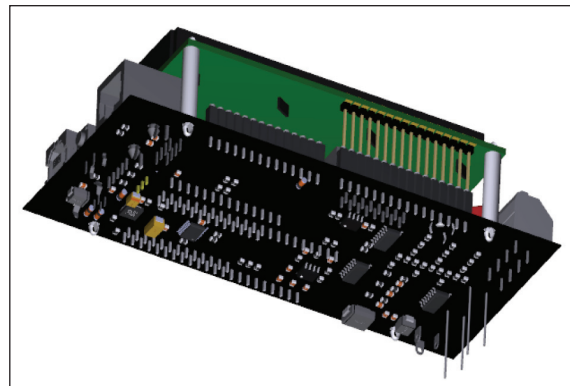

Another activity was to develop and test the device. In this sense, the necessary materials and equipments were purchased. The electronic components were attached to the printed circuit board. The device was tested in laboratory. First it was calibrated by comparing with other equipments and then was tested with standard signals by comparing with results obtained with consecrated monitoring devices.

"Intellectuals solve problems, geniuses prevent them."

Albert Einstein

Finally the device was tested with real signals obtained by applying real data to programmable signal generators

Results:

The main result of the project is the prototype of the voltage dip monitoring device. In these conditions the results can be detailed as follows:

- Prototype of the monitoring device;
- Digital document containing the electrical circuits of the printed circuit board;
- Technical details regarding mounting of electronic components;
- Technical details regarding device assembly;
- Technical documentation regarding software update;
- Technical documentation regarding using the device.

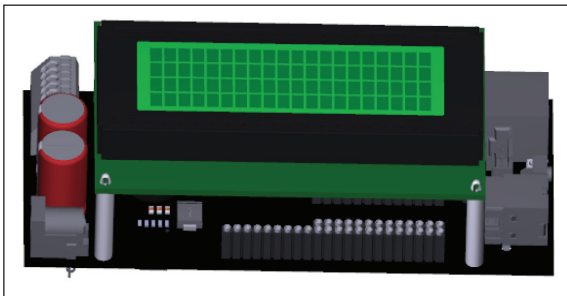

New technology used in this device and also the entire monitoring device represent intellectual properties and will be protected accordingly.

The beneficiary of the project (SC Rheel SRL) receives the prototype of the device together with all results mentioned above. Also, the beneficiary came into possession of source code of the software part of the monitoring device. The beneficiary will make all the necessary efforts to homologate the device and to insert in mass production and commercialization.

So it can be said that the goal of the project (to transfer the know-how from University to industry) was achieved.

Fields of interest: The main fields of interest connected with the project applicability and implementation, in electrical networks, are: voltage dips (monitoring and analysis), power quality (monitoring and analysis, including all power quality parameters and indices); embedded system for power engineering.

Financed through/by:

Executive Agency for Higher Education, Research, Development and Innovation Funding through Innovation Support Services (Innovation Checks) component of the Innovation Programme and is part-financed by SC Rheel SRL, contract id: PN-II-IN-CI-2012-1-0150.

Research team:

Dr. Eng. Florin MOLNAR-MATEI, Dr. Eng. Mihai MOGA, Dr. Eng. Adrian PANĂ, Dr. Eng. Alexandru BĂLOI

Research centre:

Research centre for Power Systems Analysis and Optimization

Applicability and transferability of the results:

The results obtained during research project were entirely transferred to the beneficiary of the research project and can be applied in industry for mass production. The equipment can be installed in electrical network for voltage dips monitoring, at any voltage level, both by electrical energy suppliers and consumers.

Contact information:

As. Dr. Eng. Florin MOLNAR-MATEI
 Address: V. Parvan, No. 2, 300223, Timișoara, Romania
 Tel./Fax.: (0040) 256 403 428
 Mob.: (0040) 766 647 539
 E-mail: molnar_matei@yahoo.com
florin.molnar@et.upt.ro

"Intellectuals solve problems, geniuses prevent them."

Albert Einstein

Goal of the project: The main objective of the project is designing, testing and making a prototype of a micro solar plant to produce electricity and heat using Fresnel lenses and Stirling engine at the price of 1 Euro / W. The specific cost of electricity produced by PV panels is 3Euro/W. Comparing the prices; the product will be competitive on internal and external markets.

Short description of the project: Making the installation is based on the utility model certificate no.RO 2010 U 00057/29.07.2011 issued by OSIM. The model suggests as a technological innovation the use of Fresnel lenses and Stirling engine. Energy chain links will produce at the same time mechanical energy, thermal energy and electric power. The plant will use Fresnel lenses for the concentration of the radiation and Stirling engine to convert solar energy into mechanical energy. Mechanical energy is converted into electricity by an alternator. Thermal solar conversion will provide thermal energy for the hot source of the Stirling engine.

Project implemented by: This project is implemented by the Department "Physical Fundamentals of Engineering" in collaboration with SC ENERGOSOPHIA Ltd as contractor/customer.

Implementation period:
29.06.2012 – 05.12.2012

Main activities: Studies for this project started by reinterpreting the obtained results from previous measurements on heliothermal potential in the western part of Romania. All necessary equipment's and parts were purchased for making this installation. On 16 Nov at BFI headquarters an important meeting took place.

The analyzed themes were: insolation and weather factors in the western part of Romania, using Fresnel lenses for concentrating solar radiation, using Stirling engine in solar applications, using an alternator and inverter, project management. A proposal of an invention was submitted for OSIM by Energosophia.

Results:

a) Measurement results indicate that local solar potential is comparable to that of other EU countries that are successfully implementing innovative solar installations.

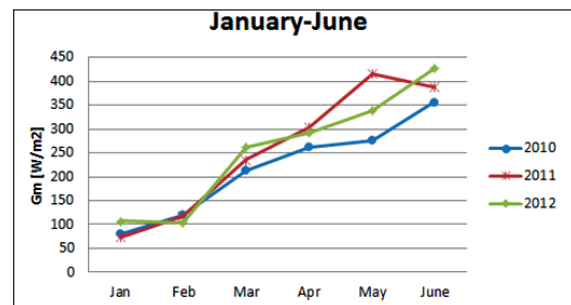

b) At „Installations for Constructions and Ambient Comfort” Conference from 11-12 April 2013, 4 scientific papers were proposed for communication and publication.

c) The invention “Solar Thermo Electrical Plant with Fresnel Lenses” was accepted for patent litigation. This invention is intellectual property of an author from Energosophia and it will be protected.

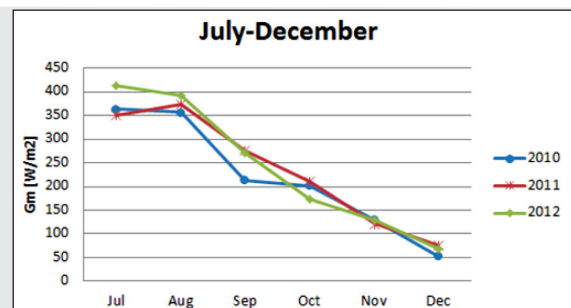

“If you want to find the secrets of the universe, think in terms of energy, frequency and vibration.”

Nikola Tesla

d) Measurements planned for the period with insolation in 2013 will lead to some papers concerning solar energy which will be presented at national and international conferences. These papers are designed to disseminate the results, and also the educational and public interest concerning renewable energy, namely solar energy.

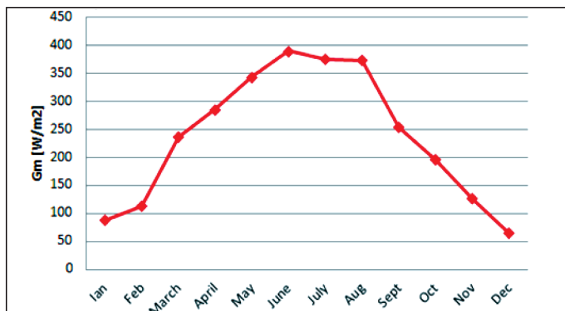

e) The installation is part of the program called Directive 2006/32/CE and part of the new energy politics of EU from 2007, called "20-20-20" which suggests the apparition in the market of new innovative products. Comparative studies will be developed concerning energy efficiency, feasibility of heat pipe tubes, PV panels and Fresnel lens installation and also Stirling engine.



f) Partnership development between BFI and Energosophia

Fields of interest:

- Areas of interest concerning this product consist of the industrial energy consumers, public and private for electricity, thermal energy and mechanical energy and also the energy supply sector.
- It is expected that electricity prices will drop from 3euro/W at 1 euro/W; installation

possibilities generated will be attractive in the medium and long term.

c) Commercial attractiveness of the product will create for Energosophia Company the possibility of developing by increasing the turnover and the number of employees.

d) Developing the theoretical basis of the functionality of the plant will stimulate paper development to be proposed in journals.

e) Didactical processing of functionality mechanisms will be interesting for students and masters students of engineering faculties.

f) At the same time the installation will be useful for PhD students in development of solar energy conversion topics and in other forms of energy.

Research Centre: Research centre for advanced study methods for physics phenomena.

Financed through/by: Ministry of Education, Research, Youth and Sports through the Program Innovation from PN II, subprogram Services for Innovation - Innovation checks.

Research team: *From BFI:* 1. Assist. Prof. Dr. Ioan Luminosu - Director; 2. Prof. Dr. Eng. Dumitru Toader; 3. Prof. Dr. Eng. Aldo De Sabata; 4. Assist. Prof. Dr. Ciprian Sorandaru; 5. Assist. Prof. Dr. Virgil Stoica; 6. Msc student Mirela Enache. *From Energosophia:* 1. Assist. Prof. Dr. Traian Zamfir; 2. Eng. Felix Zamfir; 3. Eng. I. Dinculescu.

Applicability and transferability of the results:

The results are applicable and transferable to: a) public administration, b) public and private energy consumers, c) for energy suppliers, d) industry.

Contact information:

Dr. Ioan Luminosu
Address: V. Parvan Street, No. 2, Timisoara
Phone/fax: (0040) 256 403 391
Mobile: (0040) 731 015 456
E-mail: ioan.luminosu@et.upt.ro

"Our energy is an expression of cosmic energy"

Deepak Chopra



Goal of the project:

This project is based on interaction of different areas of partial differential equations, stochastic differential equations and dynamical systems whose common denominator is the theory of semigroups of linear operators. The main objective of the project is to study the L_∞ -uniqueness of some pre-generators from mathematical-physics.

The project fits in the CD priority areas 10 - Basic Sciences, subdomain 10.1 - Mathematics.

Short description of the project:

The specific objectives of the project concern the study of some theoretical problems such as the existence, uniqueness, perturbation and approximation of C_0 -semigroups on the dual of a Banach space, and some applications on the L_∞ -uniqueness of diffusion operators, which are pregenerators.

We expect that the methods presented here can be used to attack several uniqueness problems in the infinite dimensional case.

Fields of interest:

According to the 2010 Mathematical Subject Classification of A.M.S., the fields of interest are: 47D06 (one-parameter semigroups and linear evolution equation), 60J60 (diffusion processes), 81Q10 (selfadjoint operator theory including spectral analysis).

Implementation period:

14.04.2011-30.11.2012

Project implemented by:

The Department of Electrical Engineering and Industrial Informatics from „Politehnica” University of Timișoara, Romania, in partnership with the Department of Economics Defence from Military Economics Academy of Wuhan, P. R. China.

Main activities:

The first phase of execution was held between 14.04.2011-30.11.2011. The main activity in this phase was the visit of the Romanian research team at the Military Economics Academy of Wuhan, P.R. China, from October 9 to 25, 2011. The second phase of implementation took place from 1.01.2012 to 30.11.2012.

“Attitude is a little thing that makes a big difference.”

Winston Churchill

The main activities in this phase were the visit of a Chinese research team at „Politehnica” University of Timișoara, Romania, in the period 10-21 June 2012, and the visit of a part of the Romanian team at Military Economics Academy of Wuhan, P.R. China, in the period 9-16 October 2012.

During these visits were conducted more research in accordance with the phase’s objectives and some related activities.

Results:

The main results obtained are consistent with the objectives and reflects their performance. Some of these results were presented at international conferences and published in journals included in the ISI database or other internationally recognized databases. Another part of these results are in press or under review for publication.

Also, we have organized a Chinese-Romanian Symposium on Inter-government Joint Research.

Project in 18-19 October 2011 at Wuhan and in 18-19 June 2012 at Hunedoara.



Financed through/by:

PNII Program– Capacities
Modul III – Bilateral cooperation
Contract A.N.C.S. nr.514/14.04.2011.

Research team:

Politehnica” University of Timișoara team:
L.D. Lemle, F.L. Pater, D.M. Stoica
Military Economics Academy team: Y. Jiang,
Z. Guo.

Applicability and transferability of the results: We expect that the methods presented here can be used to attack several uniqueness problems in the infinite dimensional case.

As a consequence of this project, „Politehnica” University of Timișoara in cooperation with Military Economics Academy of Wuhan, University of Wuhan and Huazhong University of Science and Technology will organize the International Conference on Applied Sciences:
<http://www.icoas2013.net/index.htm>



Contact information:

Ludovic Dan LEMLE
Universitatea “Politehnica” Timisoara
Facultatea de Inginerie din Hunedoara
Str. Revoluției, nr. 5
331128 – Hunedoara, România
Tel: +40254207500
Fax: +40254207501
E-mail: dan.lemle@fh.upt.ro
<http://www.fh.upt.ro/personal/dan.lemle>

“Attitude is a little thing that makes a big difference.”

Winston Churchill

Goal of the project: In this project, we seek suitable compact models, together with the analysis and synthesis of texture images. The overall objective is to improve existing methods of classification of textures using statistical approaches in the field of complex transforms, namely the hyperanalytic wavelet transform.

Short description of the project:

Stochastic modeling of natural images is the subject of many applications: denoising, filtering, classification, compression, synthesis. The purpose is to have a statistical model of the image information. There is a large variability for natural images so a transform domain can be more appropriate. We propose to use a new transform with enhanced selectivity and quasi shift invariance, the hyperanalytic

wavelet transform (HWT) proposed by the Romanian team and a new family of multivariate models based on copula theory proposed by the French team.

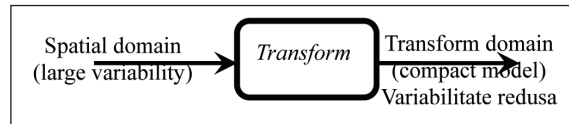

Project implemented by: Members of the Intelligent Signal Processing Research centre ISPRC, UPT, in partnership with members with members of the laboratory LAPS, of IPBENSEIRB MATMECA, from Bordeaux, France.

Implementation period: 31.03.2011-10.12.2012.



“At every level the greatest obstacle to transforming the world is that we lack the clarity and imagination to conceive that it could be different”

Roberto Unger

Main activities:

Main activities for 2011: study and simulation of texture classification techniques and statistical analysis of a new implementation of a complex transform, namely the hyperanalytic wavelet transform, HWT, which is quasi shift invariant and has an improved directional selectivity. These different properties can be expected to lead in a better estimation of relevant stochastic parameters. The main objectives for 2012 were: applying stochastic criteria for texture classification in HWT domain. A novelty is the use of the copula model together with the interdependencies inter/intra level, as well as inter/intra subband, for the complex coefficients.

Another objective was to evaluate the proposed techniques on well known texture databases, such as VISTEX or OUTEX using several criteria such as mean percentage of classification.

Results:

The final results have been disseminated in international scientific journals and conferences by the Partners. The activities were developed during the visits by the two teams: July 2011, (visit to Romania), November 2011 (visit to France), October 2012 (visit to France). In August 2012, the Romanian team as well the French director Yannick Berthoumieu participated to EUSIPCO 2012 in the framework of Brancusi, in order to present our paper on the Kullback-Leibler divergence for complex models usable in texture classification. One French collaborator attended the ISETC 2012 symposium organized in Timisoara, to present our common paper.

Fields of interest:

Signal and image processing, statistical signal processing.

Financed through/by:

ANCS/UEFISCDI, EGIDE.

Research team:

UPT team: Assist. Prof. Dr. Eng. Corina Nafornta (director), Prof. Dr. Eng. Alexandru Isar, Prof. Dr. Eng. Ioan Nafornta. *ENSEIRB MATMECA team:* Prof. Dr. Eng. Yannick Berthoumieu (director), Researcher Dr. Flavius Turcu, Researcher Dr. Ioana Turcu.

Research centre:

Research Centre for Intelligent Signal Processing- ISPRC

Applicability and transferability of the results:

The Signals Processing lab run by Professor Yannick Berthoumieu already has a known tradition in relations with industry partners, especially with Total, which allows us to believe the results obtained will be used. The Intelligent Signal Processing research centre "Adelaida Mateescu" from Timișoara had collaboration on denoising sonar images with IFREMER Brest and will continue it on image segmentation. We will use these results also in the framework of the Francophone Master Programme, Traitement du signal from the Communications department.

Contact information:

Corina NAFORNITA
Address: 2 Blvd Parvan, 300222, Timișoara, Romania
Phone/Fax.: (0040) 256 403 318
E-mail: corina.nafornta@gmail.com
Web: <http://www.tc.etc.upt.ro/isprc>
<http://www.tc.etc.upt.ro/isprc/context.html>

Goal of the project: ARTRAC aims to develop an active safety system to protect vulnerable road users (VRUs) from vehicles in motion that is economically viable in the volume vehicle market.

The safety system will consist of both actuators for controlling vehicle driving dynamics and the perception component for the vehicle's surroundings. It will be tested on two types of vehicles that pose the biggest hazard to VRUs in urban settings, namely cars and light delivery goods vehicles.

Short description of the project:

The environmental sensing used in ARTRAC project will be based on a single automotive 24 GHz narrowband radar sensor. This sensor offers the potential to overcome the hitherto price barrier that has prevented VRU protection systems from entering widespread use. To meet the challenging technical requirements for extremely short measurement time, reliable target detection, ego motion and road condition estimation that have to be met, a new transmit/receive antenna and multi-channel receiver will be developed. Existing microwave technology in the 24 GHz band is utilised as much as possible to facilitate low-cost mass production applications.

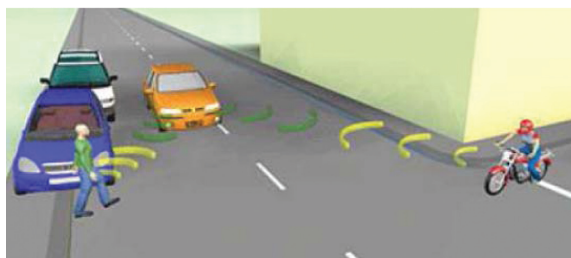

Implementation period:

01.11.2011-31.10.2014

Project implemented by: A consortium that comprises 7 partners well experienced in this sector and worldwide leaders in automotive industry and research:

- 2 car manufacturers (VOLKSWAGEN, FIAT through CRF),

- 2 research organizations (VTT - Finland, CTAG - Spain),
- 2 universities (TUHH – Technical University Hamburg-Harburg, UPT),
- one SME specialized in car sensors (SMS Germany).

Main activities: The environmental sensing will be conducted with a novel high performance but low-cost 24 GHz narrowband radar system. From an operational viewpoint, this RF frequency fits exactly into the existing ISM band from 24,000 GHz to 24,250 GHz. Due to this techno-political feature this radar has a long term perspective on European and world-wide markets.

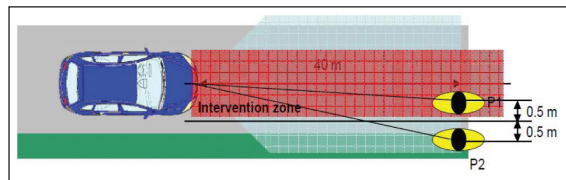

The whole system consisting of radar sensor, sensor fusion, risk assessment and vehicle control has a high potential to be launched in serial cars because the majority of components are already standard equipment in series cars.

The additional equipment required should not be a show-stopper from a pure technical point of view.

Measures for VRU protection might be divided into passive and active systems. Because of basic physical properties, passive measures can provide limited protection potential only.

Therefore (active) actuators are necessary to achieve the desired protection for VRUs. For example, vehicle deceleration seems to be a potential approach for active VRU protection with high benefit and high potential for high volume series cars, as they are already in use in high-end limousines.

"We must respect the past, and mistrust the present if we wish to provide for the safety of the future."

Joseph Joubert

Results: ARTRAC address the following six major scientific and technical objectives:

- Develop a generic detection system able to detect pedestrians, cyclists, and other vulnerable road users (VRU) as well as vehicles.
- Implement the capability to monitor road surface conditions and detect low-friction road sections caused by water, ice or snow on asphalt. This will be able to be used to warn or adapt the vehicle's electronic control systems such as electronic stability control (ESC) and collision avoidance systems (CAS) for changed friction conditions.
- Develop an electronically controllable brake and steering force system able to slow down the vehicle and provide a supported evasive manoeuvre. Drivers' reactions to hazards are too often stereotypic and slow, and their evasive manoeuvres either insufficient or incorrect.



- Provide a totally new safety function based on automatic braking and system-initiated steering recommendation to avoid accidents, or at least mitigate their impact in the event of an unavoidable crash.
- Validate and demonstrate the system functionality by means of pre-defined test scenarios. The prototype will be demonstrated within some "basic" safety applications on two vehicles types, a compact car and a light commercial vehicle.
- Promote the deployment of VRU safety technologies among relevant bodies and stakeholders, including end-users.

Research Centre for Intelligent Signal Processing- ISPRC

Fields of interest: radar, sensor, vulnerable road users, protection, road condition detection, collision avoidance, assisted brakEng.

Financed through/by: The project is part-funded by the EU 7th Framework Program.

Research team:

- TUHH (project coordinator): Prof. Dr. Hermann Rohling, Dipl. Eng. Steffen Heuel
- TuTech (project management): Axel Wegner
- Volkswagen AG (VW): Dr. Marc-Michael Meinecke, Eng. Michael Heuer
- Centro Ricerche Fiat (CRF): Eng. Stefano Mangosio
- Smart Micro Systems (SMS): Eng. Ralph Mende, Ing Karsten Schuman
- CTAG-Galicia: Eng. Marga Saez, Estrela Alvarez
- VTT: Eng. Janne Häkli, Eng. Kaj Nummila
- UPT: Prof. Dr. Eng. Ioan Naforniță, Prof. Dr. Eng. Alexandru Isar, Prof. Dr. Eng. Andrei Câmpeanu, Assist. Prof. Dr. Eng. Corina Naforniță, Drd. Eng. Adrian Macaveiu

Aplicability and transferability of the results:

The key result of the ARTRAC project will be a safety system that aims to protect vulnerable road users, designed to be economically viable in the volume vehicle market. The safety system will consist of both, actuators for controlling vehicle driving dynamics and the perception component for the vehicle's surroundings. The ARTRAC detection system will be small, lightweight and economical in order to enable an easy integration in the vehicle design.

Contact information:

Prof. Dr. Ioan Naforniță
Bv. V. Parvan nr. 1. B219, 300223,
Timișoara, Romania,
Tel./Fax.: (0040) 256 403 302
Mob: (0040) 722 567 912
ioan.nafornita@gmail.com
www.artrac.org

"We must respect the past, and mistrust the present, if we wish to provide for the safety of the future."

Joseph Joubert

Goal of the project:

The project aim was to develop electrodes based on carbon nanostructures to create sensors and intelligent microelectrodes array behaviour according to the individual and selective/simultaneous detection of some persistent organic pollutants (POPs) target analytes from water, as a solution to the urgent needs of providing enhanced timely monitoring of POPs.

Short description of the project:

This project addresses the urgent needs for providing enhanced timely monitoring of POPs in water through the development of newsensorsbasedoncarbonnanostructures with their customization (modification with transition metals functionalized zeolites), integrating these composite based sensors as microelectrodes arrays in order to obtain an intelligent sensor for simultaneous/selective detection of oxidable pollutants from water. The electroanalytical parameters for POPs detection, i.e. sensitivity, selectivity, detection limits, stability, and short response time were studied in detail. Also, the study of these sensors for application in other complementary fields, i.e., clinical analysis, pharmaceutical and food products analysis, revealed the possibility of elaboration/development of non-invasive innovative analysis techniques. These new sensors should give an advance for the monitoring of persistent pollutants and should have an important impact on water quality control, as well as on life and health quality.

Implementation period:

05.08.2010-27.07.2012

Research Centre for Environmental Science and Engineering

Project implemented by:

The Faculty of Industrial Chemistry and Environmental Engineering from UPT.

Main activities:

Two new composite electrodes types based on carbon nanotubes / carbon nanofibers one unmodified, and the other modified with functionalized zeolite have been developed. Functionalized zeolite and carbon nano-structures were trapped in the epoxy matrix. After composite electrodes elaboration, specific techniques for the structural and electrochemical characterization and detection experiments have been applied.



The electrochemical techniques optimal conditions for analysis have been established, and the behaviour of obtained sensors as microelectrodes network has been tested. Then, the degree of recovery for each proposed optimal detection method on real waters, and enriched with known quantities of pollutant has been assessed. The accuracy of the proposed detection methods has been evaluated relative to the conventional ones. The adaptation availability of these sensors for detection of some compounds of interest in medicine, pharmacy and food products has also been accomplished.

"Few scientists acquainted with the chemistry of biological systems at the molecular level can avoid being inspired."

Donald Cram

Results:

- Development of new transition metals (Ag/Cu) functionalized zeolite modified composite electrodes based on carbon nanomaterials;
- Established interferences and optimal conditions of the new sensors for individual detection of target POPs from waters;
- Exploiting the multiple pulse amperometry characteristics to enhance the detection electroanalytical performances;
- Establishing of selectivity, specificity, detection limit, concentrations range, measurements accuracy, interferences and fouling/defouling conditions of electrodes for simultaneous detection of organic pollutants from real waters;
- Correlation between amperometric signal and conventional parameters for real waters.

For increasing of the Romanian research international visibility, all the scientific results has been communicated and published in prestigious journals in mainstream publications of the field. The quantifiable contributions are: 10 papers published in ISI Web of Knowledge indexed journals, one published book chapter and one submitted patent application.

Fields of interest:

The main fields of interest related to project applicability and implementation are: control system for the POPs in the environment and noninvasive quantitative evaluation of some compounds of interest in fields such medicine, pharmacy and food industry.

Financed through/by:

Romanian Ministry of Education, Research and Innovation, The National Authority for Scientific Research – UEFISCSU, contract PNII-RU-PD no 129/2010.

Research team:

Dr. Eng. Aniela POP

Applicability and transferability of the results:

Benefits of this pollution detection way allow the improvement of water quality management, with on-site organics monitoring, reducing response time and avoiding water sampling and conditioning. The potential beneficiaries of these types of sensors are: analysis and research laboratories, environmental protection agencies (especial for on-site pollutants monitoring, water quality control, risk assessment), pilot plants and plants for wastewater treatment.

Contact information:

Dr. Eng. Aniela POP
 Address: B-dul Vasile Parvan, no 6, 300223, Timișoara, Romania
 Tel./Fax.: (0040) 256 403 069
 Mob.: (0040) 723 528 667
 E-mail: anielapop@yahoo.com
aniela.pop@chim.upt.ro

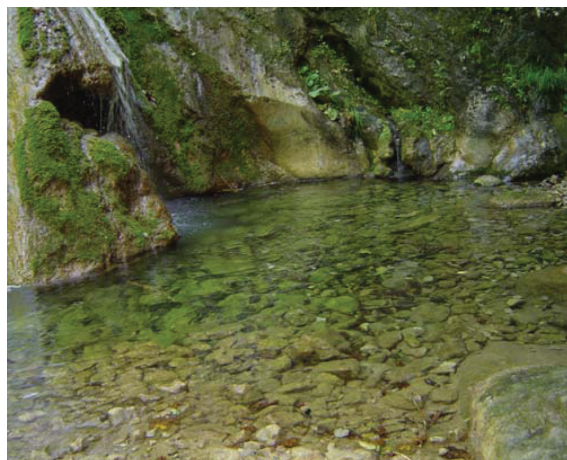

Goal of the project:

The main goal of the project is to develop the electrochemistry application field in water treatment and quality control, by creating the right framework for achieving the high research level.

This project aims to explore potential use of nanoenhanced electrochemical dual green technology to improve access to clean water.

Short description of the project:

Starting with the results obtained in our previous studies for the oxidation of pollutants in aqueous solutions for their degradation and/or their detection on the carbon-based electrodes, the specific project objectives are:

1. Elaboration and manufacturing of some new electrodes types based on nanostructured carbon and Ag/Cu/TiO₂ modified zeolite with enhanced electro(photo)-catalytic activity;
2. Manufacturing, design and geometry conditions of electrodes for degradation and monitoring applications;
3. Setting-up the optimal conditions for the degradation and mineralization of priority organic pollutants (POPs) from water;
4. Elaboration of the electrochemical detection scheme;
5. Integration of the electrochemical detection methods within the control of the degradation and the mineralization of POPs in aqueous solutions.
6. Development of a new nano-enhanced electrochemical green dual technology for integrated water treatment and control.

Fields of interest: Water treatment and water quality monitoring

Financed through/by: UEFISCDI

Main activities:

1. Elaboration of new composite materials based on carbon nanotubes (CNT)/carbon nanofibres (CNF) in epoxy matrix as electrode materials for oxidation of POPs from water;

2. Characterization of new composite materials based on carbon nanotubes (CNT)/carbon nanofibres (CNF) in epoxy matrix and electrode design;
3. Composite electrode obtaining and selection for application in degradation and/or detection of POPs from water;
4. Assessment of electro(photo)catalytic performance of the selected electrodes in advanced degradation/mineralization of POPs from water;
5. Assessment of the electroanalytical performance of the electrode in detection of POPs from water. Optimization of the electroanalytical method;
6. Integration and optimization of the electrode materials and electrochemical techniques in water treatment and process control.

Results:

1. Series of composite electrodes using epoxy matrix with different compositions based on CNT/CNF and natural or synthetic zeolite doped with Ag/ Cu/TiO₂ in epoxy matrix;
2. Application of the new electrodes in advanced water treatment process; published papers;
3. Procedure for the electroanalytical detection of POPs from water;
4. Elaboration of nano-enhanced electrochemical green dual technology for water treatment and process control;

Research team: Florica Manea-director, Rodica Pode-senior researcher, Aniela Pop-researcher, Dr. eng. Anamaria Baci-researcher assistant, Sorina Motoc-researcher assistant.

Research centre for Environmental Science and Engineering

Contact information:

Assoc. Prof. Dr. Eng. Florica Manea
florica.manea@chim.upt.ro

.....
"Water is the driving force of all nature."

Leonardo da Vinci

Goal of the project:

The main goal of the project is to develop and implement the integrated system of innovative technologies and management tools for reducing the impacts and the risks associated to the environment and human health due to the water quality issues, throughout the entire cycle of its use: sampling from natural sources, treatment, distribution, use, collection and treatment of wastewater and final discharge and reuse.

Short description of the project:

The specific objectives were defined at the level of whole water usage cycle:

1. Development of specific tools for the identification, quantification and control of environmental impact and risk within the entire water resources use cycle, applied at the level of industrial water operators;
2. Development of cooperation and technological transfer between universities and water operators from Timis and Iasi counties for control of environmental impact and associated risk on the human health within the entire water use cycle;
3. Development of research and institutional capacities of project partners to facilitate the further cooperation at the national and the international level;

Project implemented by:

- SC Aquatim SA Timisoara
- SC Apavital SA Iasi

Research centre for Environmental Science and Engineering

Main activities:

1. Integrated evaluation of the water use cycle;
2. Studies on impact and risk minimization through innovative water treatment process (removal of nitrate, nitrite and natural organic matter);
3. Studies on impact and risk minimization through innovative wastewater treatment processes (removal of priority organic pollutants);

4. Pilot-scale studies on impact and risk minimization in water treatment;

5. Pilot-scale studies on impact and risk minimization in wastewater treatment for reuse.

Development of an integrated monitoring system for water-related impacts and risks survey;

6. Development and testing of integrated management instruments for impact and risk prediction and minimization over the water use cycle;

7. Integration and optimization of the electrode materials and electrochemical techniques in water treatment and process control.

Results:

1. Two innovative assessment instruments: the - integrated environmental-human related impact and risk assessment and the environmental impacts assessment based on the grey water footprint concept;
2. Technical documentation on the optimal technology for water treatment pilot system;
3. Pilot scale system for the advanced water treatment;
4. Life cycle assessment methodology for assessing water systems

Financed through/by: UEFISCDI

Research team:

- Florica Manea-partner responsible
- Rodica Pode-senior researcher
- Laura Coheci-researcher
- Aniela Pop-researcher
- Anamaria Baciuresearcher as.
- Sorina Moto-researcher as.
- Magdalena Ardelean-researcher as.
- Agnes Jakab-researcher as.

Contact information:

Assoc. Prof. dr. eng. Florica Manea
florica.manea@chim.upt.ro

"Water is the driving force of all nature."

Leonardo da Vinci

Goal of the project:

The project suggests several innovative solutions to optimize the combustion method, thus allowing the preparation of nanocrystalline compounds of practical interest, with large surface area, such are: $BaAl_2O_4$, Al_2TiO_5 , $ZnAl_2O_4$, $LaAlO_3$ or $YAlO_3$.

Short description of the project:

Preparation of ceramic powders with controlled properties under more advantageous conditions is a real challenge for the field of ceramics. One of the recently developed synthesis methods is the solution combustion synthesis, which in some cases yields the designed crystalline compounds directly from the combustion reaction, no further annealing being necessary.

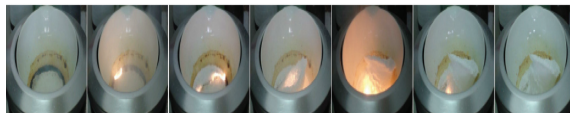

BaAl₂O₄ combustion synthesis evolution

However, in some cases, the initial version of the combustion method does not lead to satisfying results. Often, the reaction products are amorphous and/or contain residual carbon. Therefore, the formation of the desired phase may be achieved only after a subsequent annealing, which leads to grain growth and low surface area powder.

Novel solutions are approached within the project, in order to optimize the original version of combustion synthesis: the use of new organic fuels; the use of fuel mixtures; the removal of residual carbon by hydrogen peroxide chemical oxidation; the use of passive retarding salt additions; the use of metal nitrate/fuel molar ratios with fuel excess.

Project implemented by:

„Politehnica” University of Timisoara

Implementation period:

10.2011 – 09.2014

Main activities:

Management and communication:

Conducting the public procurement procedures. / Preparation of intermediate and final progress reports. / Monitoring and internal control of the project implementation process. / Results processing and elaboration of scientific materials (articles, OSIM patent application, posters, presentations). / Results dissemination and attending international conferences. / Creating and updating a project web site.

Research:

- increasing the surface area of $ZnAl_2O_4$ powders by **removing the residual carbon via H_2O_2 oxidation**
- combustion synthesis of nanocrystalline $BaAl_2O_4$ powders, with large surface area, **using new organic fuels**

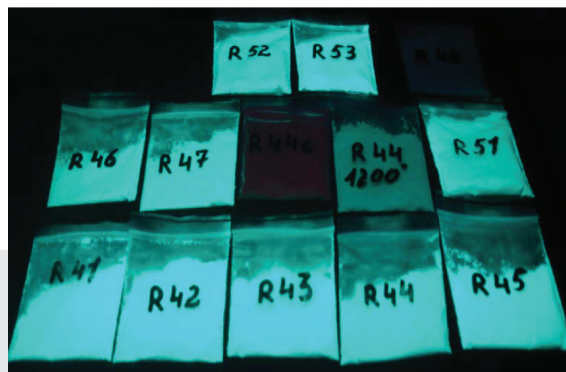

Eu²⁺/Dy³⁺-doped BaAl₂O₄ phosphor materials obtained within the project.

“Research consists in seeing what everyone else has seen, but thinking what no one else has thought.”

Albert Szent-Gyorgyi

- study: the influence of passive retarding (moderator) salt additions on the combustion synthesized LaAlO_3 powders
- study: the use of fuel mixtures in the solution combustion synthesis of YAlO_3 powders
- combustion synthesis of pure and doped Al_2TiO_5 powders

Results (by 01.01.2013):

1. Literature study on zinc spinel (Ro)
2. Project site at:
<https://sites.google.com/site/proiectpniirute201130024/> and
<http://www.upt.ro/pfe10.php>
3. Scientific paper: Robert Ianos, Radu Lazău, Ioan Lazău, Cornelia Păcurariu, **Chemical oxidation of residual carbon from ZnAl_2O_4 powders prepared by combustion synthesis**, Journal of the European Ceramic Society, <http://www.sciencedirect.com/science/article/pii/S0955221911006777> (Impact Factor 2010: 2.574, Relative score of influence, January 2012: 5.932)
4. Scientific paper: Robert Ianos, Radu Lazău, Roxana Băbută, Silvana Borcănescu, Cristian Renato Boruntea, **Nanocrystalline BaAl_2O_4 powders prepared by aqueous combustion synthesis**, Ceramics International, <http://www.sciencedirect.com/science/article/pii/S0272884212008802> (Impact Factor 2010: 2.574, Relative score of influence, January 2011: 1.751)

Fields of interest:

Materials science, ceramic powder preparation, combustion synthesis.

Financed through/by:

UEFISCDI, Executive Agency for Higher Education, Research, Development and Innovation Funding Human Resources

PROGRAMME, Research projects for the stimulation of the funding of young independent research teams (TE)

Research team:

Project leader: Ianos Robert
Researcher: Lazău Radu
Researcher: Borcănescu Silvana
Researcher: Băbută Roxana

Research centre for Environmental Science and Engineering

Aplicability and transferability of the results:

Given the novelty of the suggested solutions, the project is expected to have a high impact and lead to remarkable scientific and economical results in terms of sustainable development. The results obtained within the project will be disseminated as scientific papers in ISI – ranked publications or communicated within relevant international conferences. Some of the results and conclusions will be also included in the teaching activities performed by members of the implementation team at “Politehnica” University of Timisoara.

Contact information:

“Politehnica” University of Timisoara
Faculty of Industrial Chemistry and Environmental Engineering
P-ta Victoriei No. 2, Timisoara 300006
Tel. 0040-256-404167
Fax 0040-256-403060
robert_ianos@yahoo.com
radulazau@gmail.com

Project site: <http://www.upt.ro/pfe10.php>

“Research consists in seeing what everyone else has seen, but thinking what no one else has thought.”

Albert Szent-Gyorgyi

Goal of the project: The main goal of the joint project was to establish an interdisciplinary crossborder research network, which was going to pursue the following objectives.

1. HPLC-MS and HPLC-CD analysis and synthesis of the bioactive flavanolignan components of *Silybum marianum*.



2. Synthesis of optically active O- and O,Nheterocycles of potential pharmacological activity with kinetic resolution and organocatalysis.

3. Structure elucidation and characterization of new compounds by MS and spectroscopic methods, determination of their absolute configuration by chiroptical methods.

Short description of the project: The essential role of optical activity and stereochemistry in pharmacological activities has been already recognized, and an increasingly larger portion of chiral drugs are used as a single enantiomer. In order to get a single enantiomer of pharmacological interest, one has to be proficient in a number of fields such as the isolation and synthesis of optically active compounds, enzymecatalyzed kinetic resolution, determination of stereochemistry and characterization by mass spectrometry (MS) and NMR spectroscopy.

The participating research groups merged their scientific experience and resources to achieve the main objectives of the project.

Project implemented by: The Department of Applied Chemistry and Engineering of Organic and Natural Compounds, in cooperation with the University of Debrecen, Department of Organic Chemistry (leading partner of the project).

Implementation period:
01.04.2011 - 30.09.2012

Main activities:

1. Synthesis of 1,4-benzoxazepines and resolution of stereoisomers
2. Kinetic resolution of the sec-alcohol intermediates by enzymes
3. HPLC and GC analysis of synthetic and natural compounds



Hungary-Romania
Cross-Border Co-operation
Programme 2007-2013

Results: Several substituted racemic tetrahydro-2-methyl-2,6-metano-2H-1-benzoxocin-4-on- and -4-ol derivatives were synthesized in Domino reactions. The enantiomers were separated by chiral HPLC and the appropriate absolute configurations were allocated. 2,3,4,5-tetrahydro-1,5-benzoxazepine synthesis has been investigated by several reaction pathways. The best method included three steps, synthesis of the 4- chromanone oxime, Beckmann transposition of this oxime, and reduction of the 2,3,4,5-tetrahydro-1,6-benzoxazepin-4-one intermediate. Condensation of 2,3,4,5-tetrahydro-1,4-benzoxazepine with 2-fluoro-5-nitrobenzaldehyde was initiated, with different catalytic systems. Among these catalytic possibilities, the Buchwald-Hartwig reaction yielded the highest product amount.

"The saddest aspect of life right now is that science gathers knowledge faster than society gathers wisdom."

Isaac Asimov

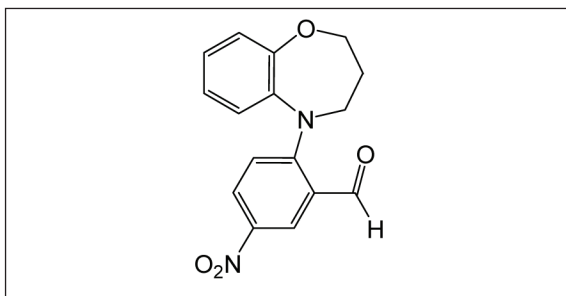

Various lipases were immobilized by the sol-gel method and tested for optical resolution of model racemic secondary alcohols. Chiral GC and HPLC have been used for monitoring of the reactions. A combined method of sol-gel entrapment and adsorption on a porous material was also investigated, as well as utilization of ternary precursor systems. Various parameters influencing the immobilization yield and efficiency, as molar ratio of silane precursors, nature of catalyst and additives, enzyme/silane ratio, etc., were studied and optimized. Lipases from *Candida antarctica* and *Pseudomonas cepacia* showed the best results for optical resolution of heterocyclic compounds.

Important advantages of employing immobilized biocatalysts are less contamination of the reaction products with undesired protein, and possibility to increase the productivity of the process by reutilization of the enzyme in several reaction cycles.

Fields of interest:

The main fields of interest connected with the project applicability and implementation are organic chemistry and biotechnology. Synthesis of possible new bioactive components with pharmacological properties represents one of the most important topics in organic chemistry.

Enzyme-catalyzed kinetic resolution represents an innovative solution in the field of optically active compounds synthesis.

Coupled MS techniques and chiroptical methods are innovative techniques for structure elucidation of natural and synthetic products.

Financed through/by: Hungary-Romania Cross-Border Co-operation Program 2007-2013 (www.hurocbc.eu), partfinanced by the European Union through the European Regional Development Fund, Hungary and Romania, Priority Axis 2 Strengthen social and economic cohesion of the border area, Action 2.2.2. Realization of joint research projects.

Research team:

UPT team: Prof. Dr. Eng. Francisc Peter (project manager assistant), Assist. Prof. Dr. Eng. Vasile Bercean, As. Dr. Eng. Cristina Paul, Eng. Ramona Croitoru, Eng. Anca Ursoiu.

University of Debrecen team: Assoc. Prof. Dr. Tibor Kurtán (project manager), Prof. Dr. Sándor Antus, Dr. Katalin Gulácsi, Dr. Attila Mándi

Research Centre for Organic, Macromolecular and Natural Compounds' Chemistry and Engineering

Applicability and transferability of the results:

All implemented original solutions and approaches were validated by publication in scientific journals and presentation at scientific conferences, consequently they are available for the scientific community. The biological activity of the synthesized compounds will be evaluated, for potential transfer to interested companies.

Contact information:

Prof. Dr. Eng. Francisc Peter
University „Politehnica” of Timișoara, Faculty of Industrial Chemistry and Environmental Engineering, C. Telbisz 6, 30001 Timișoara
Tel (0040) 256 404216
Fax (0040) 256 403060
Email: francisc.peter@chim.upt.ro

“The saddest aspect of life right now is that science gathers knowledge faster than society gathers wisdom.”

Isaac Asimov

Goal of the project:

The main goal of the NEZEBUILD project relates to the design and detailing of a technical solution for NZEBs, and to the validation of such designs through extensive monitoring. Design, detailing and execution do not allude solely to construction elements but also to installation systems.



Short description of the project:

In Dumbravita, (near Timisoara) Timis county, a residential building has already been constructed as a double house. Under these circumstances, constant monitoring of hygro-thermal parameters is being carried out. Based on the data provided by the monitoring system, a detailed evaluation of energy performance shall be carried out. In respect with the monitored elements, the equipment can be divided into 10 major groups. Naturally, it can be stated that all the important hygro-thermal and climate parameters will be monitored.

Project implemented by:

Project partnership comprising "Politehnica" University of Timisoara - CCI Department and Arhitim.

Implementation period: 2012-2015

Main activities:

Design and detailing of NZEB system, procurement of materials, equipment and energy performance certification for NZEB system / research report / Scientific papers. Evaluation of energy performances for the PH using recorded monitoring data, execution of construction works and installation of HVAC system, design of the monitoring system, procurement and set-up of equipment and accessories for NZEB and initializing of the monitoring activities. PH vs. NZEB comparative study on energy efficiency, Optimization of global cost for NZEB and evaluations regarding Life-cycle assessment of NZEB. Life-cycle assessment of NZEB, dissemination of recommendations and general rules for new energy efficient residential houses in temperate climate.

Results:

Expected results of the project as well as end products go hand-in-hand with the appointed objectives of the project. Thus, the main end products are the deliverables, in the form of detailed guidelines, plans and recommendations that shall be drawn up.

Research report including project design of NZEB and evaluation and presenting sustainable solutions for architectural details.

Documents which attest the build-up the finishing and installation system and Energy certification of the Passive House building using real energy consumption.

Recording the comfort parameters of the NZEB and report charts of monitored parameters.

"The energy of the mind is the essence of life."

Monthly Monitoring Data Sheets related to the envelope and to indoor and outdoor conditions and comparative study related to the efficiency of NZEB versus PH based on monthly evaluation of consumed energy, as well as comparative study on real behaviour of efficient buildings.

Global cost analyses report and Life Cycle Assessment of the NZEB system and elaborating a useful guide for designers and researchers related to the NZEB.

The main results consist of exhaustive knowledge and fathom of NZEB systems. However, during implementation of the project is most probable that the research team will achieve important new findings and will generate patents for some subassemblies.

Fields of interest:

Energy efficiency;
Nearly Zero Energy Building;
Passive House;
Advancement of energy-efficiency of buildings with all aspects of environmentally, economically and socially sustainable construction sector.

Financed through/by:

The project is financed by Romanian Ministry of Education through the UEFISCDI entity, in the framework of PN – II – PT – PCCA – research program.

Research team:

PROJECT MANAGER:
Assoc. Prof. Dr. Eng. Daniel DAN
TEAM MEMBERS:
Prof. Dr. Eng. Valeriu STOIAN
Assit. Prof. Dr. Eng. Tamas NAGY-GYORGY
As. dr. Eng. Sorin-Codrut FLORUT
As. dr. Eng. Cosmin DAESCU
Eng. Simon PESCARI, PhD student
As. dr. Eng. Calin SEBARCHEVICI

Research Centre for Retrofitting of Constructions

Applicability and transferability of the results:

The topic of the project and the issues that it addresses are of great importance not only for Romania and Europe, but for all of the developed countries in the world which can afford to apply measures for enhancement of energy efficiency.

The most important target groups of individuals, to whom the results and end products of the project will be most interesting, is represented by the scientists and specialists working on energyconsumption projects. Another targeted group of the project are stakeholders who can take real actions for sustainable energy consumption by adjusting the way they approach buildings, both new and existing ones.

All issued documents in the shape of deliverables will assure the transfer of knowledge intra- and inter-disciplinary, generating further know-how for scientific community and for practicing specialists (civil and environmental engineers, electrical and energy engineers, architects, technicians). Furthermore, the guidelines would enable and encourage architects and planners to properly consider the optimal combination of improvements in energy efficiency and use of energy from renewable sources when planning, designing, building and renovating industrial or residential areas.

Contact information:

Assoc. Prof. Dr. Daniel DAN
Politehnica "University" of Timisoara
Faculty of Civil Engineering
CCI Department
2nd T. Lalescu, 300223 Timisoara, Timis, România

"The energy of the mind is the essence of life."

Aristotle

Goal of the project:

The key objectives of the INSPIRE project are to evaluate retrofit strategies of existing buildings regarding their technological applicability, economic performance, impact on primary energy and CO₂-emissions, and interactions with other retrofit needs and to seek for adequate and tailored policy strategies and instruments, depending on building types, actors and institutional or country contexts.

Short description of the project:

The National Research Financing Bodies (NRFB) of Denmark, Finland, Romania, Sweden and Switzerland have jointly agreed to finance the work in the INSPIRE Project. Therefore, for formal reasons the work done in each country is defined as a sub-project of that country. However, the achievement of the goals of the project requires close cooperation between the partners and consequently international coordination of the work.

“Politehnica” University of Timisoara together with VTT Technical Research Centre have been involved in developing the Working Package 2 of the project, entitled: *Case studies on Sustainable Renovation in Eastern and Northern Europe*.

The goal of WP2 is to adapt the renovation experience of prefabricated concrete residential buildings in Finland to Eastern European countries, with focus on technological, economic, institutional and policy settings. Concrete residential buildings represent the largest retrofitting challenge in Eastern Europe and one of the best opportunities to substantially improve energy efficiency of residential buildings.

Project implemented by:

TEP Energy GmbH, Switzerland.

Implementation period:

01.03.2011 –15.12.2012.

Main activities:

The project has the following focus areas: (1) Inventory of building typologies; (2) Design practices in Romania; (3) Renovation experience in Finland; (4) Technology overview; (5) Retrofit market in Romania and Eastern European countries; (6) Business models for sustainable retrofitting; (7) Implementation of technology; (8) Detailed analysis of case studies.

Results:

The increasing number of retrofitted buildings reaching requirements of advanced building standards is an indicator for the availability and feasibility of energy-efficient technologies. The project assesses the economic effectiveness and viability of such retrofits and reveals the impact of factors such as scope, time horizon, interest rate as well as energy price expectations and preferences. Retrofit strategies to reach ambitious targets of primary energy reduction and CO₂ mitigations at low life cycle costs are identified for different building typologies. This is done both in a generic way referring to the building stock of the countries involved in the research, Denmark, Finland, Romania, Sweden and Switzerland, and for a selection of case studies. Some recommendations for retrofit strategies are given as conclusions.

In particular, related to WP2, one of the main issues of the existing building stock in precast reinforced concrete large panels is related to the small living area of the apartments. The repartitioning of the internal spacing through the horizontal and/or vertical unification of two or more apartments is a good solution for the improvement of interior comfort. This solution will also lead to reducing urban density. However, the repartitioning could only be performed by operating openings into the diaphragm walls and by strengthening the affected zones.

.....
“Science is a way of thinking much more than it is a body of knowledge.”

Carl Sagan

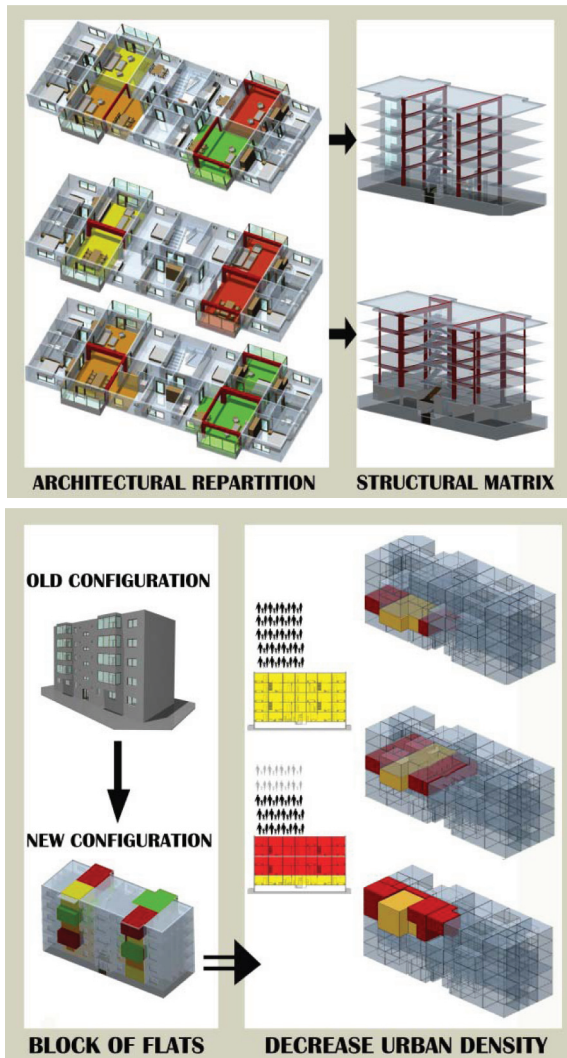

In consequence, solutions are proposed for the strengthening the affected diaphragms. They are steel-based solutions that create composite reversible structures thought for an easy erection.

Another important aspect related to these buildings represents the low thermal efficiency of envelopes. In case of the majority of buildings the thermal resistances of envelopes do not fulfil the current requirements for thermal resistance.

In a modern design, the retrofiting process is based on a multi-criterial analysis, assessing all the issues that may interfere. In the case of thermal rehabilitation at least the technical, structural and economical aspects should be considered. The sustainability should be considered

as an additional parameter in the design and constructional phase. Four solutions were proposed for thermal rehabilitation of the envelope. In the decisional process three parameters were considered: thermal resistance, environmental impact and economic aspect. A realistic estimation of parameters was performed.

Fields of interest: Retrofitting of existing concrete residential buildings.

Financed through/by:

ERACOBUILD - "Strategic networking of RDI Programmes in Construction and Operation of BUILDings" & Project type PN II ERA NET, financed by the Executive Agency for Higher Education, Research, Development and Innovation Funding (UEFISCDI), Romania.

Research team: TEP Energy GmbH, Switzerland (coordinator); Econcept AG, Switzerland; IIIIEE, Lund University, Sweden; Aalborg University, Denmark; VTT Technical Research Centre of Finland; "Politehnica" University of Timisoara, Romania.

Research centre: The Research Centre for Mechanics of Materials and Structural Safety (CEMSIG), Department of Steel Structures and Structural Mechanics, Faculty of Civil Engineering.

Applicability and transferability of the results:

The use of such solutions leads to technical advantages such as reversibility, easy erection, onshop partial manufacturing, easy interventions in case of impairment, execution quality, with impact on the existing building stock.

Contact information:

Prof. Viorel Ungureanu

"Politehnica" University of Timisoara, Faculty of Civil Engineering, Department of Steel Structures and Structural Mechanics str. Ioan Curea nr. 1, 300224 Timisoara, Romania, Phone: +40.256.403927

E-mail: viorel.ungureanu@ct.upt.ro

"Science is a way of thinking much more than it is a body of knowledge."

Goal of the project: Development of design requirements and guidelines for mitigation of progressive collapse; Development of more robust structures that can resist progressive collapse under extreme actions (natural or man-made)



Oklahoma City bombing, 1995

Short description of the project:

The project aims at defining, evaluating and modeling hazards, and at developing models for characterization of the material properties under different conditions, methods for structural evaluation and intervention strategies for mitigating the probability of collapse in case of extreme load events. Research activities will include advanced numerical analyses and full scale tests to determine the likely failure mechanisms and the extent of damage in response to the extreme load events. A consortium of five institutions is involved in the project, from which two are high ranked technical universities (PUTimisoara, UT Cluj Napoca), two are national institutes for research and development (INSEMEX Petrosani, INCERC Cluj Napoca) and one is a major construction company (ACI SA Cluj Napoca).

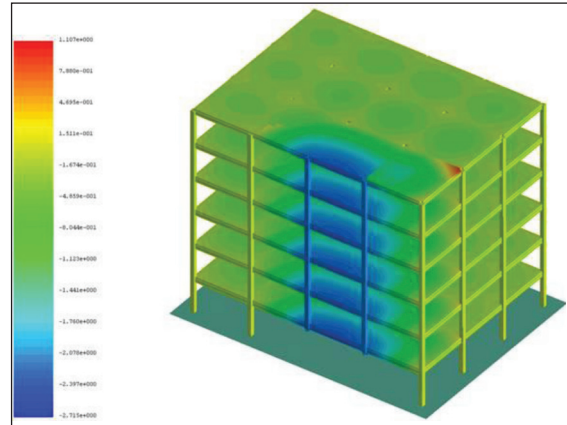

Resistance against progressive collapse by two way span systems

Project implemented by: The Research Centre for Mechanics of Materials and Structural Safety (CEMSIG), Department of Steel Structures and Structural Mechanics, Faculty of Civil Engineering.

Implementation period: 2013-2015

Main activities: The work plan is based on 7 phases and 16 scientific tasks. The scientific activity is divided into 3 main parts, which will be developed during the 3 years of the project, with the goals of yielding significant advances in the field of improving the robustness of multi-story frames in case of extreme load events.

Phase 1: Preliminary investigations; Phase 2: Design of experimental program and numerical program. Second part deals with the experimental and numerical testing; Phase 3: Experimental program on materials, weld details and macro-components; Phase 4: Experimental program on joints; Phase 5: Experimental program on sub-assemblies; Phase 6: Numerical program. The last part is devoted to the elaboration of recommendations for collapse control design of multistory frame structures; Phase 7: Design guidelines and recommendations.

"Proportion is the heart of beauty."

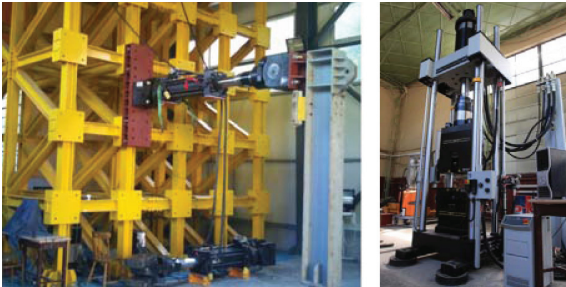

Experimental facilities at PU Timisoara

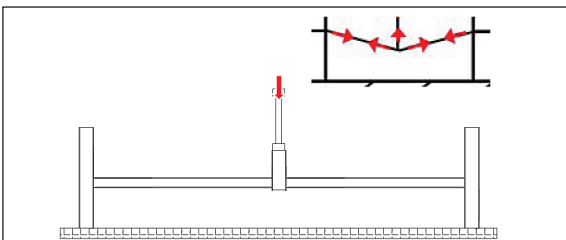

Test set-up for experimental investigation of joints

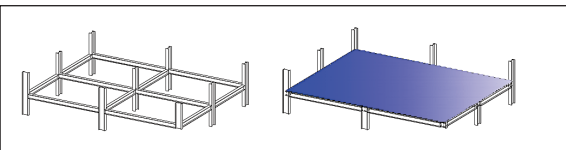

Sub-assembly specimens for corner column loss test: steel only structure (left) and steel structure with composite floor (right)

Expected results:

- A procedure to ensure general structural integrity of multi-story frame buildings will be developed. The method can be used for design of new buildings and for the upgrading of the existing ones.
- Recommendations for best practice in selection of structural system, fabrication and material requirements for improving the robustness.

Fields of interest:

- progressive collapse design of multi-storey buildings
- reduction of the vulnerability of existing structures against accidental actions
- structural reliability.

Research centre: The Research Centre for Mechanics of Materials and Structural Safety (CEMSIG)

Financed through/by:

The Executive Agency for Higher Education, Research, Development and Innovation Funding (UEFISCDI), Romania, in the frame of the Partnerships Program Joint Applied Research Projects.

Research team:

Politehnica University of Timisoara (Coord.); Technical University of Cluj-Napoca; The National Institute for Research and Development in Mine Safety and Protection to Explosion INSEMEX Petrosani; National Institute for Research and Development in Construction, Urban Planning and Sustainable Development "URBAN-INCERC"; S.C. ACI CLUJ S.A. (Industrial Partner)

Applicability and transferability of the results:

The output of the project addresses the needs of several target groups and end users:

- The academics and researchers, working within the structural engineering profession
- Technical regulations and codification drafters
- Relevant authorities, building authorities and insurance companies
- The professional engineers from design and consulting offices, constructions companies and construction materials fabricators, technical managers and decision makers from urban development and protection of building stock and urban facilities.

Contact information:

Assoc. prof. dr. eng. Florea Dinu
"Politehnica" University of Timisoara,
Faculty of Civil Engineering, Department of
Steel Structures and Structural Mechanics
str. Ioan Curea nr. 1 300224 Timisoara,
Romania
Phone: +40.256.403911
E-mail florea.dinu@ct.upt.ro
<http://www.ct.upt.ro/centre/codec.htm>

"Proportion is the heart of beauty."

Ken Follett

Goal of the project:

The proposed research aims at reducing the repair costs and downtime of a structure hit by an earthquake, and consequently more rational design approach in the context of sustainability.

Short description of the project: The objectives mentioned above are to be attained through removable dissipative members and re-centring capability of the structure. These concepts are to be implemented in a dual structure, obtained by combining steel eccentrically braced frames with removable bolted links with moment resisting frames.

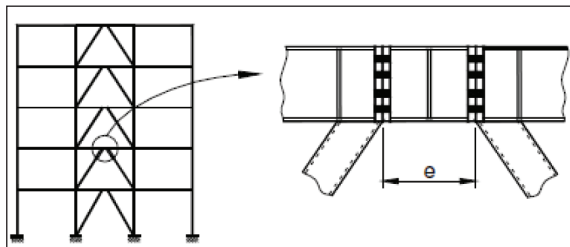

The bolted links are intended to provide the energy dissipation capacity and to be easily replaceable, while the more flexible moment resisting frames would provide the necessary recentering capability to the structure. The columns are to be realised from high strength steel, in order to keep these members in the elastic range even under strong seismic input. The validation of the proposed solution is to be realised through a pseudo-dynamic test of a full-scale model of a dual eccentrically braced structure.

Project implemented by: The Research Centre for Mechanics of Materials and Structural Safety (CEMSIG), Department of Steel Structures and Structural Mechanics, Faculty of Civil Engineering.

Implementation period:
01.06.2010 – end of 2013

Main activities:

- Numerical simulations on the test structure and links were done in order to investigate the possibility to replace bolted links following significant inelastic deformations and the practical feasibility of the replacement procedure;
- Practical solutions regarding order in which bolted links need to be replaced were developed;

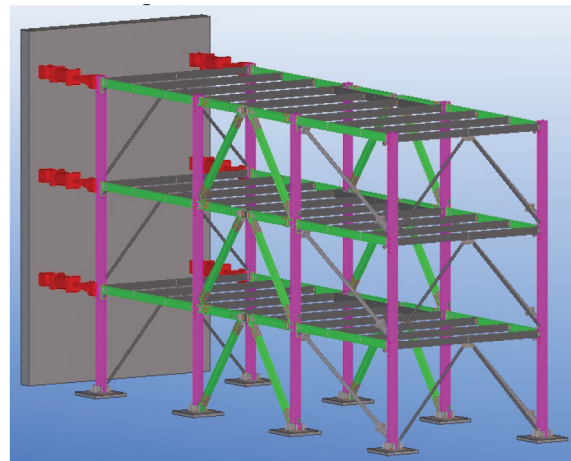

- A solution that uses temporary braces with viscous dampers mounted on the structure during link removal was analysed and chosen in order that the link removal process to be a safe one;
- Some experimental tests on one-storey onespan frames were used in order to calibrate the numeric model of the DUAREM test structure, before applying the link removal procedure.

Results:

Experimental tests on a one-story frame concluded that both the web and flanges have to be flame cut and proved the concept to be feasible, while these results were used in order to calibrate an improved numerical model of the eccentrically braced frame with removable links.

.....
"A good scientist is a person with original ideas. A good engineer is a person who makes a design that works with as few original ideas as possible."

Numerical simulation of the link removal order showed that there is negligible redistribution of forces among stories.

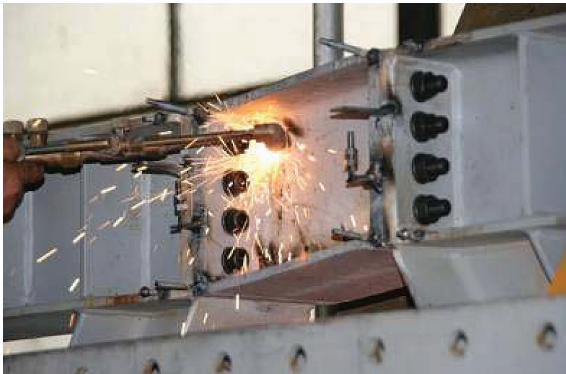

Therefore, the link replacement procedure can be performed on a story by story basis, starting from the least to the most loaded ones (from the upper story toward the lower one). As a concern of operating personnel safety during the flame cutting of links (possible sudden release of link shear force) there was analysed and adopted an alternative solution. It employs some temporary bracing and damper systems that are installed in the moment resisting bays prior to link removal.

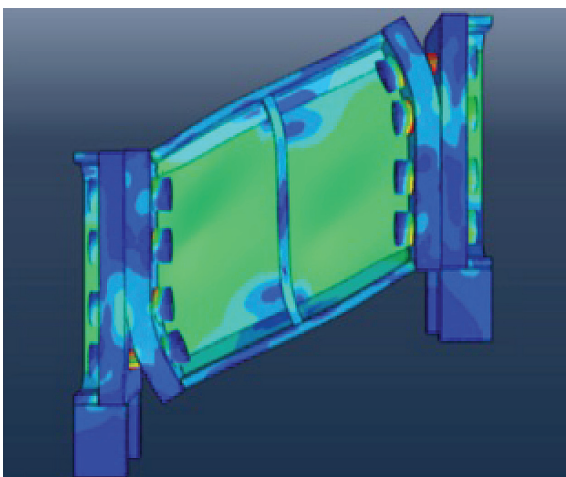

Once all links from a story are removed, all structural components from that story are in elastic range of response.

As the brace forces are released through braces with dampers, the structure recovers its initial (plumb) position.

Fields of interest: Design of steel structures in seismic areas.

Financed through/by:

European Community's Seventh Framework Programme [FP7/2007-2013] for access to the European Laboratory for Structural Assessment of the European Commission – Joint Research Centre under grant agreement no. 227887.

Research team:

- "Politehnica" University of Timisoara, Romania (coordinator)
- University of Liege, Belgium
- University of Naples "Federico II" – Faculty of Architecture, Italy
- University of Ljubljana, Slovenia
- University of Coimbra, Portugal

Research centre: Research Centre for Mechanics of Materials and Structural Safety (CEMSIG), Department of Steel Structures and Structural Mechanics, Faculty of Civil Engineering.

Applicability and transferability of the results:

After the experimental validation of the main concepts, the system can be applied to new, multistorey, dual steel structures in seismic areas and extended to buckling restrained braced (BRB) and steel plate shear walls (SPSW) systems.

Contact information:

Prof. Dan Dubina, Dr.HC., FIStructE, Corresponding Member of Romanian Academy "Politehnica" University of Timisoara, Faculty of Civil Engineering, Department of Steel Structures and Structural Mechanics str. Ioan Curea nr. 1, 300224 Timisoara, Romania
Phone: +40 256 403920
E-mail: dan.dubina@ct.upt.ro

Goal of the project: The project aims at concepts of sustainable steel building both for new-built and renovation, and based on this approach, at a novel decision-making platform that supports selection of steel-intensive solutions in the early phases of a building project. The importance of an improved knowledge basis and also methods for the early phases is highlighted by the fact that framing and typical related technologies are also selected then. The decision-making platform will be made available to various operators of the steel construction sector by The European Convention of Constructional Steelwork – ECCS.

Short description of the project: The approach of the project to sustainable building is based upon holistic valuing processes that include environmental, economic and social dimensions.

- to build-up a sustainability assessment methodology for a new or renovation building project;
- to develop a multi-criteria assessment method for an early phase of a building project;
- to develop knowledge base for performance based requirements management;
- to develop a decision-making platform that supports selection of steel-intensive solutions;
- to develop a piloting version of the service concept.

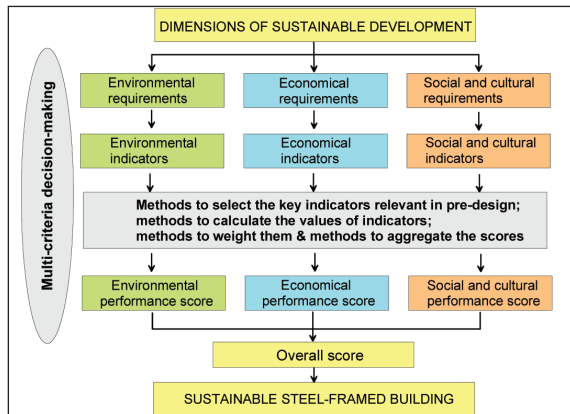
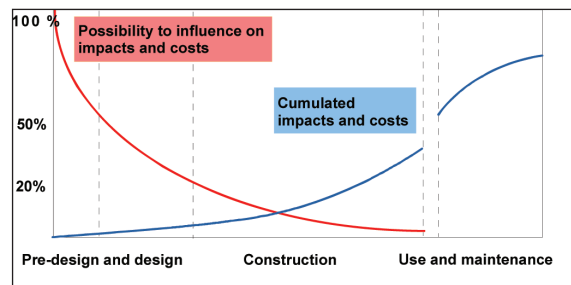

The sustainable building or renovation concept comprises the key indicators by which a building or renovation project can be steered, and later on the overall performance of a completed building can be monitored and evaluated. A hierarchy of performance criteria includes sustainability requirements.

Project implemented by: VTT Technical Research Centre of Finland.

SB_Steel develops methods and tools that are needed in the early phases of a building project. It is well known that pre-design decisions are crucial for the success of the entire construction project and for the performance and value of the completed building. The project will develop a software that will be available to various stakeholders of the steel construction sector. In order to achieve the goals, the R&D objectives of the project are:

Implementation period:

01.10.2010 –30.09.2013

Main activities:

- Identification of key indicators of sustainable steel-framed building projects;
- Assessment of the overall life-cycle’s impacts of steel framed buildings on the sustainable development, special emphasis on energy and material flows;

“Engineering is the art of organizing and directing men and controlling the forces and materials of nature for the benefit of the human race.”

Henry G. Stott

- Concept development for overall performance issues and their verification methods for a completed building during its whole life cycle (for a new build or renovated building);
- Development of a comprehensive approach to the pre-design and preliminary phases;
- Development of Environmental Software Tool aimed at a quick evaluation, at the pre-design stage, of the sustainability of steel-framed buildings, from the points of view of environmental life-cycle performance and energy efficiency;
- To provide case-studies on three steel-intensive projects in order to apply and validate the LCA-based methodology and the software tool developed.

Results:

- Identification of the case-studies; development of a data-bank of all case studies; reference design of the case studies; localization of the case studies for the various climatic regions;
- Conceptual development of the architecture of the software and flowcharting: assembly of general methodology for environmental and energy assessment of steel framed buildings;
- Implementation of the software. Based on the alternative designs, which are stored in the database, and according to the priorities given by the user to each criterion, the program provides a ranking of the alternative solutions;
- Calibration and validation of the software based on case-studies.

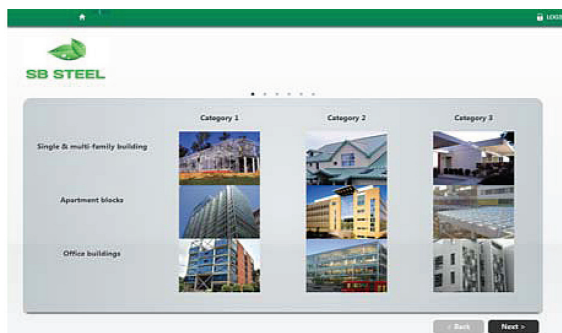

Fields of interest: Sustainability of new and existing steel structures.

Financed through/by: Research Fund for Coal and Steel.

Research team: VTT Technical Research Centre of Finland (coordinator); Acciona Infraestructuras S.A., Spain; Fundacion Tecnalia, Spain; "Politehnica" University of Timisoara, Romania; Mostostal Warszawa S.A., Poland; University of Coimbra, Portugal; University of Minho, Portugal; Aristotle University of Thessaloniki, Greece; European Convention for Constructional Steelwork ECCS, Belgium; ArcelorMittal, Luxemburg.

Research centre: Research Centre for Mechanics of Materials and Structural Safety (CEMSIG), Department of Steel Structures and Structural Mechanics, Faculty of Civil Engineering.

Applicability and transferability of the results:

The early phases of a building project are known to be most crucial for the success of the construction work and for the performance and value of the completed building. The platform is available to various operators of the steel construction sector. The piloting web-based service will be run by the European Convention of Constructional Steelwork.

Contact information:

Prof. Dr. Eng. Viorel Ungureanu
 "Politehnica" University of Timisoara,
 Faculty of Civil Engineering, Department of
 Steel Structures and Structural Mechanics
 str. Ioan Curea nr. 1
 300224 Timisoara, Romania
 Phone: +40 256 403927
 E-mail: viorel.ungureanu@ct.upt.ro

"Engineering is the art of organizing and directing men and controlling the forces and materials of nature for the benefit of the human race."

Henry G. Stott

Goal of the project:

The main goal of the project is to improve the existing knowledge on the effects of the localized fires in a building compartment. With the actual methodology included in the Eurocodes for the fire design of buildings, it is only possible to assess the temperature of a steel element in the vertical axis of the localised fire. It is impossible to assess the temperature or the flux received by a vertical member at a given distance of the fire source.

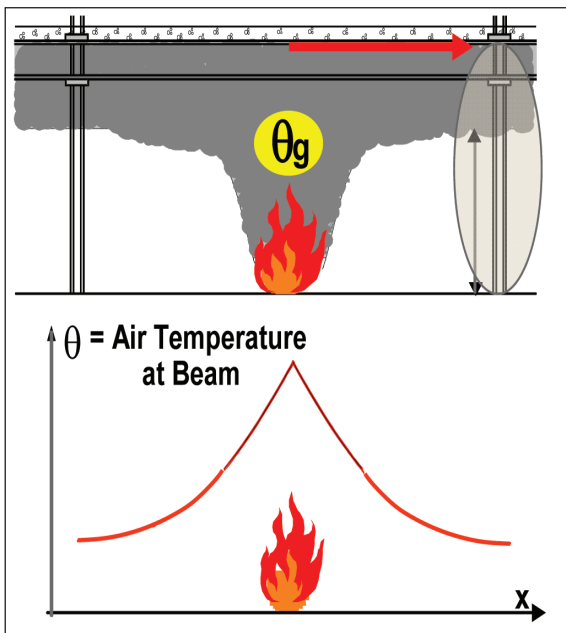

Project implemented by:

- ArcelorMittal Luxembourg (coordinator)
- Centre Technique et Industriel de la Construction Métallique, France
- "Politehnica" University of Timisoara, Romania
- Universite de Liege, Belgium
- University of Ulster, Ireland

Short description of the project:

The project is devoted to the development of an analytical model for the calculation of the temperatures in the vertical structural steel elements of a building, subjected to localised fires.

The new method, developed by means of experimental and numerical research, will provide the fluxes received in any point of a building compartment subjected to a localised fire.

Implementation period:

1 july 2012-30 june 2015

Main activities:

- Collection of the different national annexes and national parameters for the application of the Natural Fire Models in different European countries and implementation of these parameters in a Software;
- Definition and realisation of laboratory tests assessing the effect of the real flame emissivity for element engulfed into the fire;
- Definition and realisation of laboratory tests assessing the fluxes received by an element subjected to localised fire but not engulfed in the fire;
- Development and validation using CFD models of simplified analytical model for the evaluation of the fluxes received by an element in any point of a compartment;
- Implementation of the developed analytical model in a user-friendly tool;
- Redaction of a design guide for the application of the new methodology including design examples

"Education is not the filling of a pail, but the lighting of a fire"

William Butler Yeats

Results:

Design procedures based on the analytical models developed within the project will be proposed.

Fields of interest:

Design of buildings in fire situation

Financed through/by:

EUROPEAN COMMISSION
DIRECTORATE-GENERAL FOR RESEARCH
AND INNOVATION
Research Fund for Coal and Steel - RFCS

Research team:

Associate Professor Raul Zaharia
(coordinator for „Politehnica” University
of Timisoara) Professor Dan Dubina, C.M.
of the Romanian Academy Assistand
Professor Dan Pintea

Research centre:

Research Centre for Mechanics of

Materials and Structural Safety (CEMSIG),
Department of Steel Structures and
Structural Mechanics, Faculty of Civil
Engineering.

Aplicability and transferability of the results:

The analytical models developed within
the project will be introduced in a user
friendly software and in an advanced
calculation model for fire design, in order
to offer a large utilization of the procedure
for the construction market.

Contact information:

Associate Professor Raul Zaharia
“Politehnica” University of Timisoara
Faculty of Civil Engineering
Department of Steel Structures and
Structural Mechanics
Ioan Curea 1, Timisoara ROMANIA
Tel. +40/256403922
e-mail: raul.zaharia@ct.upt.ro

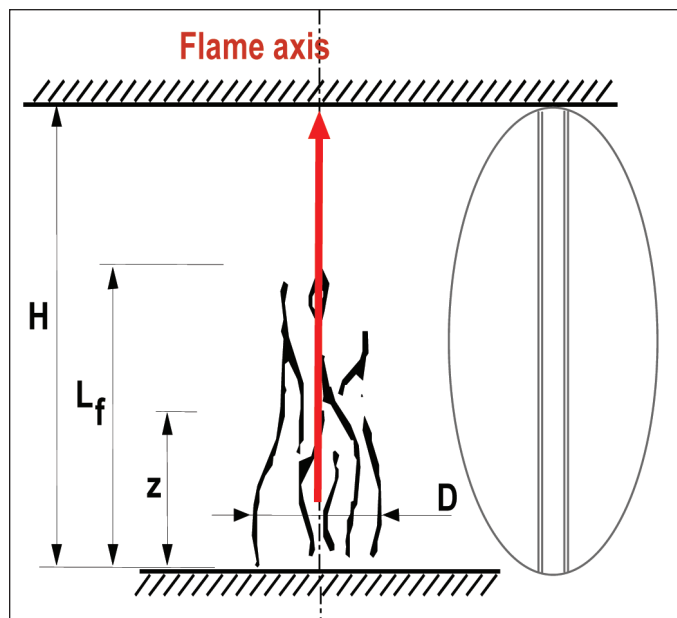

“Education is not the filling of a pail, but the lighting of a fire”

William Butler Yeats

Goal of the project

The main goal of the project is to conceive and setup a monitoring system through which all the hydrothermal parameters of a building are to be registered. All the recorded parameters are analysed in order to conclude the efficiency of the system. Another important aspect is to validate or improve energy consumption calculation methods, through real, measured data of energy consumption and to provide cost-benefit calculations for investors, architects, constructors and for private people.

Short description of the project:

In Dumbravita, (near Timisoara) Timis county, a residential building has already been constructed as a double house. Under these circumstances, constant monitoring of hygro-thermal parameters is being carried out. Based on the data provided by the monitoring system, a detailed evaluation of energy performance shall be carried out.



In respect with the monitored elements, the equipment can be divided into 10 major groups. Naturally, it can be stated that all the important hygro-thermal and climate parameters will be monitored.

Implementation period: 2011-2012

Project implemented by:

Project partnership comprising of "Politehnica" University of Timisoara - CCI Department and SolarTech South Plain Nonprofit.

Main activities:

Procurement of monitoring equipment and energy performance certification for PASSHOUSE/research reports/scientific papers.

Evaluation of energy performances for the PH using recorded monitoring data, design of the monitoring system, procurement and set-up of equipment and initializing of the monitoring activities.

Transfer of know-how to interested specialists through workshops and technical meetings.



Results:

Expected results of the project as well as end products go hand-in-hand with the appointed objectives of the project. Thus, the main end products are the deliverables, in the form of detailed guidelines, plans

and recommendations that shall be drawn up. Documents which attest the build-up the finishing and installation system and Energy certification of the Passive House building using real energy consumption.

Recording the comfort parameters of the PASSHOUSE and report charts of monitored parameters. Monthly Monitoring Data Sheets related to the envelope and to indoor and outdoor conditions.

The main results consist of exhaustive knowledge and fathom of PASSHOUSE system. However, during implementation of the project is most probable that the research team will achieve important new findings and will generate patents for some subassemblies.

Fields of interest:

Energy efficiency; Health Monitoring; Passive House; Advancement of energy-efficiency of buildings with all aspects of environmentally, economically and socially sustainable construction sector.

Financed through/by:

Hungary-Romania Cross-Border Cooperation Program 2007-2013 (www.hurocbc.eu) and is part-financed by the European Union through the European Regional Development Fund, Hungary and Romania, Action 2.2.3. Cooperation between sectors involved in R&D, contract id HURO/ 1001/221/2.2.3.

Research team:

PROJECT MANAGER:

Prof. Dr. Eng. Valeriu STOIAN

TEAM MEMBERS:

Assoc. Prof. Dr. Eng. Daniel DAN

Assist. Prof. Dr. Eng. Tamas NAGY-GYORGY

Assist. Dr. Eng. Sorin-Codrut FLORUT

Dr. Eng. BRATA Silvana

Dr. Eng. DORHOI Sebastian

Research centre for Retrofitting of Constructions – RECO, within CCI

Department, Faculty of Civil Engineering, “Politehnica” University of Timisoara

Applicability and transferability of the results:

Knowledge transfer to people about energyefficient solutions. The target groups of the project are stakeholders who can do something for sustainable energy consumption.

The topic of the project and the issues that it addresses are of great importance not only for Romania and Europe, but for all of the developed countries in the world which can afford to apply measures for enhancement of energy efficiency.

The most important target groups of individuals, to whom the results and end products of the project will be most interesting, is represented by the scientists and specialists working on energyconsumption projects. Another targeted group of the project are stakeholders who can take realactions for sustainable energy consumption by adjusting the way they approach buildings, both new and existing ones.

All issued documents in the shape of deliverables will assure the transfer of knowledge intra- and inter-disciplinary, generating further know-how for scientific community and for practicing specialists. Furthermore, the guidelines would enable and encourage architects and planners to properly consider the optimal combination of improvements in energy efficiency and use of energy from renewable sources when planning, designing, building facilities.

Contact information:

Prof. Dr. Eng. STOIAN Valeriu
Politehnica “University” of Timisoara
Faculty of Civil Engineering
CCI Department 2nd T. Lalescu, 300223
Timisoara, Timis, România

Goal of the project: The project aims to find reliable structural typologies and connection detailing for dual-steel building frames, and to validate them by tests and advanced numerical simulations. Another goal is to develop design criteria and performance based design methodology for dual-steel structures using high strength steel, and to evaluate the technical and economical benefit of dual-steel approach involving high strength steel.

Short description of the project: A robust seismic resistant structure should be provided with balanced stiffness, strength and ductility among component members and connections. According to dissipative design philosophy, such a structure will be able to dissipate a part of energy induced by the ground motion through plastic deformations in dissipative zones of ductile members, e.g. beams in Moment Resisting Frames (MRF), links in Eccentrically Braced Frames (EBF) or braces in Concentrically Braced Frames (CBF).

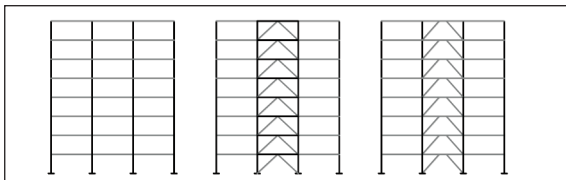

MRFD-CBFD-EBF

Consequently, the project investigates and evaluates the seismic performance of dual-steel building frames, realised from two different steel grades: Mild Carbon Steel (MCS) and High Strength Steel (HSS). Dual-steel structural systems, in which MCS is used in dissipative members while HSS is used in non-dissipative “elastic” members, can be very reliable and cost efficient. The main outcomes of the project consist in coherent performance based design methodology and relevant design criteria for ductility and overstrength of members

and joint components, as well as joint detailing rules.

Project implemented by: The Research Centre for Mechanics of Materials and Structural Safety (CEMSIG), Department of Steel Structures and Structural Mechanics, Faculty of Civil Engineering.

Implementation period:
01.07.2009 – 30.06.2013

Main activities:

- Evaluation of the seismic performance of dual-steel frames;
- Tests on weld details and T-stubs;
- Tests on bolted beam-to-column joints with PE-WF columns, and CF-RHS columns;
- Tests on welded stiffened, and welded cover plate joints with FE-WF columns;
- Tests on welded beam-to-column joints (RBS / CP) with CF-RHS;
- Guidelines for conceptual design and PBD of dual-steel building frames under seismic actions;
- Evaluation of technical and economic efficiency of dual-steel structures;

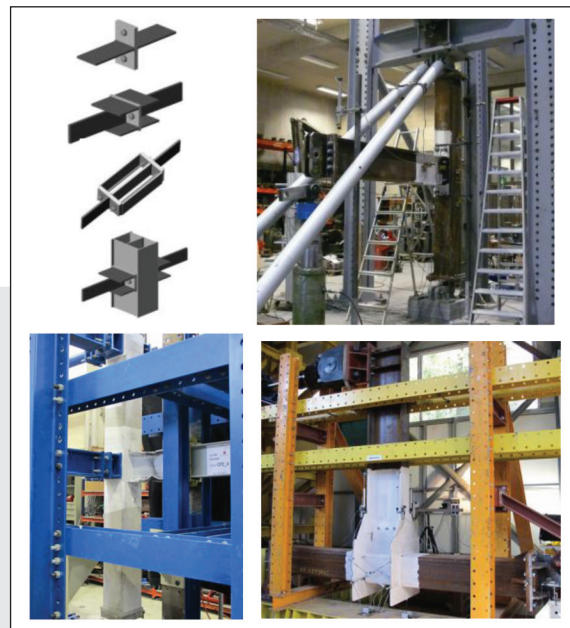

“Engineers participate in the activities which make the resources of nature available in a form beneficial to man and provide systems which will perform optimally and economically.”

L. M. K. Boelter

Results: Analyses and parametric studies were performed on five structural typologies (120 case studies). Experimental investigations of material samples, weld details and T-stubs, steel-concrete connection, and beam-to-column joints are in process of finalisation and the interpretation and evaluation of experimental data is in progress. For a better understanding of the behaviour of the tested beam-to-column joint configurations, advanced numerical investigations were performed as well, i.e. calibration of the numerical models of the joints, and extension of the experimental program with additional cases.

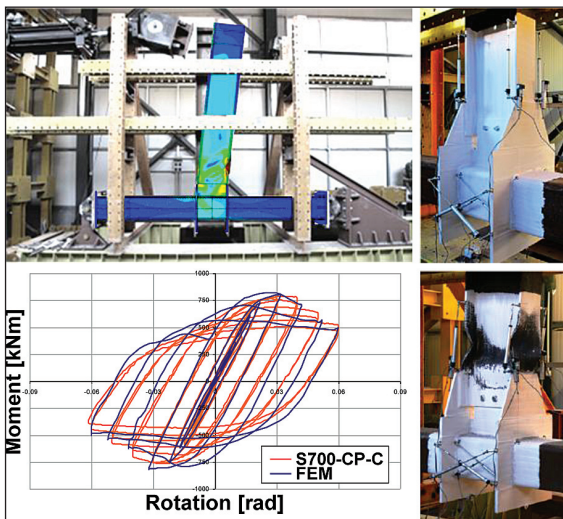

The experimental investigations performed on beam-to-column joints under monotonic and cyclic loading evidenced a good conception and design of the joints – characterized by a good rotation capacity and energy dissipation. The current activities are related also to the development of design and detailing rules for connections and joints, design methodology and criteria for frames, as well as evaluation of technical and economical benefit of dual-steel approach involving high strength steel.

Fields of interest: Seismic resistant structures for multistorey building frames.

Financed through/by: Research Fund for Coal and Steel.

Research team: “Politehnica” University of Timișoara, Romania (project coordinator); RIVA Acciaio S.p.A, Italy; Consorzio Pisa Recherche CPR, Italy; VTT Valtion Teknillinen Tutkimuskeskus, Finland; University of Liege, Belgium; University of Stuttgart, Germany; University of Naples “Federico II”, Italy; University of Ljubljana, Slovenia; Gabinete de Informática e Projecto Assistido por Computador Lda., Portugal; Rautaruukki Oyj (RUUKKI), Finland

Research centre: Research Centre for Mechanics of Materials and Structural Safety (CEMSIG), Department of Steel Structures and Structural Mechanics, Faculty of Civil Engineering.

Applicability and transferability of the results: The importance of the research lies in following the currently increasing market quality request, allows finding margins of improvement in quality constructional steel production to face foreseeable competition with emerging Asian producers. The results are directly transferable to the steel industry and to the world of structural design of steel constructions, aiming to develop and harmonise production and design regulations. The expected advantages of HSS Dual Steel building technology structural solutions will allow promoting steel and steel-concrete composite constructions with respect to reinforced concrete solutions, actually more widespread in seismic countries, in Europe and outside of Europe.

Contact information: Prof. Dan Dubina, Dr.HC., FStructE, “Politehnica” University of Timisoara, Faculty of Civil Engineering, Department of Steel Structures and Structural Mechanics str. Ioan Curea nr. 1, 300224 Timisoara, Romania
Phone: +40.256.403920
E-mail: dan.dubina@ct.upt.ro

“Engineers participate in the activities which make the resources of nature available in a form beneficial to man and provide systems which will perform optimally and economically.”

L. M. K. Boelter

Goal of the project:

The European project thinkMOTION is intended to offer knowledge in the field of mechanisms and machine science through the portal Europeana on a specialized site called DMG-Lib. DMG-Lib is a digital library, which provides content originating from a large range of sources (universities, technical libraries, museums, patent offices, individual owners etc.). The content posted on DMG-Lib presents information in more categories: books, articles, proceedings, PhD thesis, contributions, journals, reports, biographies, images, interactive animations, software and so on. One of the main goals of the project is the retrieval of mechanism science in its history. Almost all content before 1990 exists in analogue form, written, printed or drawn on paper support. Getting back and gathering national historical treasures in a well-organized collection requires digitization of a large amount of documents. The digital library offers a novel way of describing the history of development in mechanism science field, from antiquity up to nowadays.

Short description of the project:

The processing of an item starting with an analogue document and ending up to having high-quality online information was planned to pursue the following workflow:

- locating of potential content providers, owning the rights of use granted by the owner of intellectual property and getting the physical support carrying content;
- performing the primary digitization by means of specially designed equipment, in order to obtain raw scanned images of the original document;
- processing the raw images with appropriate software so that the quality of images matches imposed standards and the final files are web-compliant; (fig. 1)

- digitization of images;
- generation of CAD files in order to provide movies, interactive animations and CAX files;
- contributing with Romanian scientists biographies to a Who-is-Who European Collection;
- posting the items online.

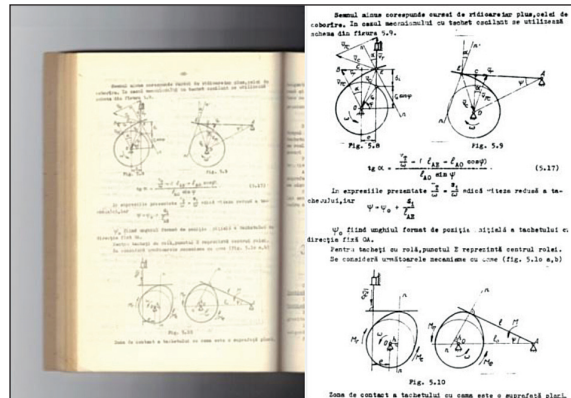

Fig. 1. Raw scanned image of a page book (left) and its final digitized look online (right)

Project implemented by:

Partners from:

- Ilmenau University of Technology (IUT, Germany);
- University of Basque Country (UBC, Spain);
- Politehnica University of Timisoara (UPT, Romania);
- RWTH Aachen University (RWTH, Germany);
- French Institute of Advanced Mechanics (IFMA, France) and;
- University of Cassino (UCAS, Italy).

"God determines how fast you're going to run; I can only help with the mechanics."

Bill Bowerman

Implementation period:

10.06.2012-31.05.2013

Main activities:

The workpackages within the project are briefly described below:

WP1: Coordination, project management and quality assurance

WP2: Adaptation to interfaces to Europeana

WP3: Locating and providing relevant sources and clarification of rights of use

WP4: Digitizing heterogeneous input content

WP5: Processing of digitized content and integration into DMG-Lib

WP6: Entering metadata for content

WP7: Collection and systematization of information about important persons in mechanism science

WP8: Multilingual translation of metadata

WP9: Sustainability and exploitation

WP10: Dissemination, awareness activities and staff development

Results:

• designing and assembling of a performant scanning equipment; (Fig. 2)

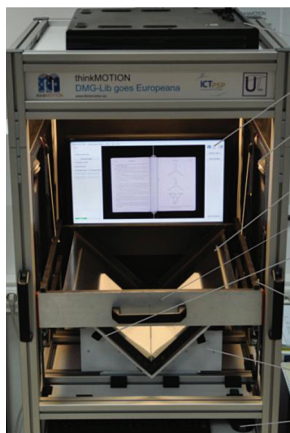

Fig. 2. Scanning equipment developed at UPT

• digitization and processing of a large amount of documents (about 6500 titles);
 • generation of digital items such as movies, CAD files, 2D and 3D images of mechanisms, interactive animations;

• posting of 140 biographies of persons and descriptions of universities that are significant in Romania.

Fields of interest: mechanism and mobile mechanical systems, software development and implementation, multilingual digital library

Financed through/by:

The Information and Communication Technologies Policy Support Program; Area: CIP-ICT-PSP.2009.2.3-Digital Libraries: European Digital Library Digitizing content for Europeana

Research team:

Erwin-Christian Lovasz, Inocențiu Maniu, Corina Mihaela Gruescu, Iosif Cărăbaș, Valeriu Ciupe, Dan Mărgineanu, Rodica Militaru, Carmen Sticlaru, Agneta Lovasz, Eugen Zăbavă, Dan Perju, Liana Dehelean, Nicolae Dehelean, Valer Dolga, Ivan Bogdanov, Diana Resiga, Veronica Argeșanu, Andreea Dobra, Endre Ianoși, Cristian Emil Moldovan, Sanda Grigorescu, George Savii, Țucu Dumitru, Liviu Bereteu, Valeria Văcărescu, Voicu Mesaroș-Anghel, Mihaela Jula, Aurel Diaconu, Ioan Doroftei, Dan Sergiu Stan, Dan Mândru, Angela Repanovici, Corneliu Rădulescu.

Research centre for Mechatronics and Robotics

Applicability and transferability of the results: Results are available on the site of DMG-Lib (dmg-lib.org) and the portal Europeana. They address to students, PhD students, engineers, teachers and so on. The content is useful for education and research purposes.

Contact information:

Erwin-Christian Lovasz
 e-mail: erwin.lovasz@mec.upt.ro
 Corina Mihaela Gruescu
 e-mail: corina.gruescu@mec.upt.ro

"God determines how fast you're going to run; I can only help with the mechanics."

Bill Bowerman

Goal of the project: Cystic fibrosis is a genetic, life limiting disorder. Daily airway clearance techniques and regular sport activities are recognized as the key element of care for children and teenagers with cystic fibrosis. However the compliance of airway clearance techniques is not satisfied among teenagers. The objective of this study is to optimize physiotherapy management of people with CF in Romania and to create a complex, smart and useful strategy to follow.

The purpose of this research project is to initiate an independent research program, which aims to develop scientific research potential of the team of young scientists and researchers and to obtain significant scientific results, internationally competitive, capitalized through communication and publication in International journals in the field of physiotherapy in cystic fibrosis. Creating a research program that aims to acquire new knowledge to optimize physical therapeutically intervention in patients with cystic fibrosis.2. Building an interdisciplinary team of young scientists and researchers and the integration of researchers who are still in training in such a research team.3. The validation of a complex physical therapy protocol.4. The increase of potential and international visibility of the research team and the host institution of the project.

Short description of the project: Physical therapy is an integral part of cystic fibrosis suffering patient management, being one of the treatment's objectives contributing to the increase of the quality of life of these patients. Success depends on the optimal pairing of individualized physical training, respiratory clearance techniques and inhaling therapies. It is very difficult for young people to accept a very strict and precise therapeutically regimen, especially when it comes to a chronic and incurable disease.

We believe that by developing a flexible protocol based on the combination of incentive techniques, respiratory clearance techniques, and individual physical training based on continuous monitoring, we will increase the compliance and effectiveness of the treatment.



Research Centre for Medical Engineering

Implementation period:

09.08.2010-01.07.2013

Main activities:

We propose the creation of a prospective study lasting 25 months which will include 40 subjects aged between 14 and 18 years, diagnosed with cystic fibrosis and whom have the agreement of their legal gardiens to participate in this research project. Subjects will be randomly assigned into: Group S (study) - they will make individualized physical training based on the modern technologies available in the project (multi-bio-impedantometrie, dynamometer, myotest systems and monitoring heart rate with pulsmeters); incentive therapy techniques (using device trainair) and respiratory clearance; and Group C (control)- they will follow standard physical therapy programs conducted in the National Centre for Cystic Fibrosis, with no incentive therapy techniques.

"Like music and art, respect for the environment is a common language that can transcend political or social boundaries."

Jimmy Carter

The initial evaluation will be followed by reassessment of the same parameters at 6, 12 and 24 months. The design and monitoring of physical therapy programs will be based on data provided by the initial assessment and re-evaluations during the semester. We believe that the results of the final evaluation will illustrate the upgrading of the pursued parameters which result in a better quality of life.

Results:

Participation of the team members in scientific meetings with paper works:

- “Physical Education and Sports in Health Benefit” 38 edition (25 – 26 may 2012)
- 18th European Congress of Physical and Rehabilitation Medicine (28 may - 01 June, 2012)
- 35th European Cystic Fibrosis Conference, Dublin, Ireland (5-9 June, 2012)
- World Congress of Performance Analysis of Sport IX, 25 – 28 July, 2012, Worcester, England
Conference “diversity education, education diversity “, (20-21 September 2012), Timisoara
- National Conference of Cystic Fibrosis (17-18 November 2012), Bucharest.
- 4th Conference Excellence in paediatrics, 28 November- 1 December 2012, Madrid, Spain
- 3 articles ISI, Bogdan Almajan-Guta, Alexandra Rusu, Claudiu Avram, Increasing quality of life in Romanian Cystic Fibrosis teenagers using a complex approach of physiotherapy-ISI proceedings, la 18th European Congress of Physical and Rehabilitation Medicine Edition, ogdan Almajan-Guta, S. Gheltofan, M.Oravitan Supervised and home based kinetic programs in children with Down syndrome ISI proceedings, la 18th European Congress of Physical and Rehabilitation Medicine Editione Minerva Medica, 1 with impact factor T. Slavici, B. Almajan-Guta, Efficient recommendation of proper physiotherapy exercises for patients with cystic fibrosis using artificial intelligence techniques. Journal of Rehabilitation Medicine,

2012 and 3 in international data base: Ornela O. Cluci, Bogdan Almajan-Guta, Claudiu Avram, Alexandra M. Rusu, Importanța testului de mers 6 minute în evaluarea tinerilor cu fibroză chistică din Romania, Timisoara Physical Education and Rehabilitation Journal, nr. 8,vol 4, 2012,ISSN 2065, Almajan Guta B , Rusu A, Cluci O, Almăjan Guță V, S Gheltofan, Rolul și eficiența aplicării fizioterapiei pe termen scurt și lung la copiii cu fibroză chistică, Timisoara Physical Education and Rehabilitation Journal, nr.7, vol4, 2012, ISSN 2065-057, Bogdan Almajan-Guta, Modificari ale compozitiei corporale la pacientii cu mucoviscidoza dupa programe complexe de kinetoterapie respiratorie, Oradea, vol 18/ nr 30/2012 Decembrie, pag 5 / 12, Revista Romana de Kinetoterapie, ISSN 1224-6220

Fields of interest:

Physiotherapy and sport activities in patients with cystic fibrosis.

Financed through/by:

UEFISCSU Romania, Human Resources, Young Teams TE/36.

Research team: Almajan Guta Bogdan, Members Avram Claudiu, Rusu Alexandra, Cluci Ornela

Applicability and transferability of the results:

Combining incentive therapy and individualized sport training with airway clearance techniques leads to significant improvements in respiratory function, body composition and aerobic fitness level which are the most important factors for optimizing quality of life in teenagers with cystic fibrosis. We are working with the patients with CF trying ti improve their quality of life.

Contact information:

Assist. Prof. Dr. Almajan Guta Bogdan
bogdisport@yahoo.com
www.mucoviscidoza.com
Tel: +40722723537

“Like music and art, respect for the environment is a common language that can transcend political or social boundaries.”

Jimmy Carter

Goal of the project: The main goal of this project is to develop an industrial module capable of ultrasonic assisted drilling/grinding, being this system independent, removable and transportable to be used in any machine tool using standards cone adaptors such as HSK. The main innovation objectives of the project are the development of specially designed components: transducer, sonotrode, generator, tool-holder and electrical transmission.

Short description of the project: Metal cutting is one of the most important industrial processes of all manufacturing activities. Drilling represents about 30% of the total manufacturing time complementing other processes, such as turning and milling, while grinding is the most important process in the manufacturing of high precision and high quality components. The drilling process is common for the manufacturing of structural parts and components in the aeronautic sector. Most of these parts are made of titanium alloys, aluminium alloys or carbon fibre reinforced composites, and they normally need a lot of drilling operations. Furthermore, these structural parts require high precision to assure the integrity of the component in use, so the improvement of the process performance becomes a challenge that could be achieved by using ultrasonic assisted drilling to obtain precise hole diameter and cilindricity avoiding the generation of burrs. The grinding is a common process in all sectors of activity manufacturing mechanical components when high precision is required (automotive, machine tools, aeronautics, etc.).

Most of previous works in the use of ultrasonic assisted machining are oriented to the development of grinding processes.

Implementation period:
01.01.2010-31.12.2012

Project implemented by:

Department of Materials and Manufacturing Engineering from UPT in partnership with ISIM Timisoara, SC SMD electronics SRL Timisoara, Fundación Tekniker from Eibar-Spain, LAIP S.A. - Spain and MYL S.A. - Spain.

Main activities:

The activities of the project were divided in 3 phases. In the first phase, the system specifications concerning the ultrasonic system design and the machining process were done. The second phase was consisting in the development of the ultrasonic system. UPT, ISIM and SMD have designed the ultrasonic generator according to the defined specifications. TEKNIKER, UPT and ISIM have designed the ultrasonic vibratory system. TEKNIKER, MYL and ISIM have defined the electrical connection system to power the rotating ultrasonic vibratory system with the ultrasonic generator. All the partners have participated in the mechanical design and the integration of the components developed before. This phase also has included the manufacturing and assembling of the system developed. In the third phase, the validation, the development of the machining processes was done, including experimental research on ultrasonic assisted drilling and grinding processes.

Results:

It has been realized an ultrasonic activation systems (resonance frequency 40 KHz).

- Analysis of ultrasonic assisted drilling:
After some preliminary tests it was established that the ultrasonic activation should be focused for drilling small diameter parts between 3 and 8 mm. The experimental results were statistically processed and interpreted.

.....
"Scientists investigate that which already is; Engineers create that which has never been."

Albert Einstein

•Analysis of ultrasonic assisted grinding:
Using the same ultrasonic activation device,
an experimental program was realized for
ultrasonic assisted grinding process.
In both processes the reducing on cutting
forces was observed, especially for drilling
processes (in some conditions the cutting
forces reduction was 20%).

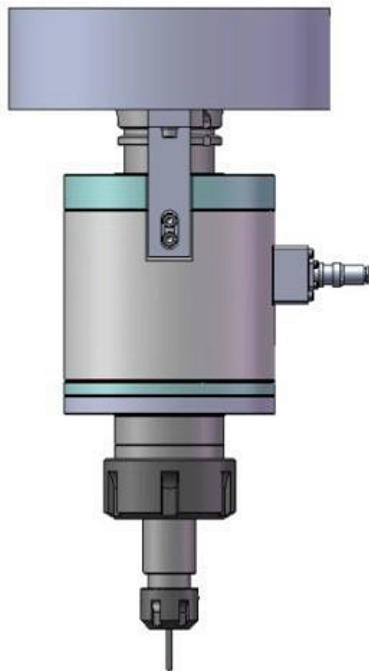

Fields of interest: The industrial needs driving the development of this technology is the manufacturing of high quality components made of materials with low machinability (Ti alloys, ceramics, hardened steels...) or very particular behaviour (carbon fibre reinforced composites, Al alloys...), providing an efficient manufacturing process suitable to be adapted to most of the machine tools and enhancing the capability of these. The introduction of new advanced technologies, like ultrasonic assisted drilling and grinding, that allow the production of high quality components becomes an important factor to maintain the competitiveness of the European

industries against low labour cost markets outside EC.

Financed through/by:

The Executive Agency for Higher Education, Research, Development and Innovation Funding (UEFISCDI), contract no. MNT 7-021/2010.

Research team:

UPT team: Dr. Eng. Cristian-Gheorghe Turc, Dr. Eng. Tudor Iclănzan, Dr. Eng. George Drăghici, Dr. Eng. Ion Grozav, Dr. Eng. Daniel Stan, Dr. Eng. Aurel Tulcan, Dr. Eng. George Belgiu, Dr. Eng. Eugen Pămîntaş, Dr. Eng. Felicia Banciu, Dr. Eng. Liliana Tulcan, Dr. Mat. Tudor Bînzar.

ISIM team: Drd. Eng. Octavian Oancă, Eng. Dan Ionescu, Eng. Nicolai Paşca, Eng. Ion Perianu, Ec. Adrian Mateescu.

SC SMD Electronics SRL Timișoara team: Eng. Manuel-Dan Skopecz, Eng. Andrei Alexa, Eng. Caius Beznoszka.

Research centre for Integrated Engineering

Applicability and transferability of the results:

- Development of a new industrial system for ultrasonic assisted drilling/grinding usable in any machine-tool.
- Improvement in the knowledge and design capabilities in the field of ultrasonics.
- Improvement of the drilling process in the manufacturing of high precision aeronautic components.
- Improvement of the grinding process in the manufacturing of high precision components.

Contact information:

Assist. Prof. Dr. Eng. Cristian-Gheorghe Turc
Address:
Facultatea de Mecanică, Dep. I.M.F., 1 M. Viteazu, 300222, Timișoara, Romania
Tel.: (0040) 256 403 609
Mob.: (0040) 728 043 170
E-mail: cturc@eng.upt.ro
Web: <http://www.eng.upt.ro/>

*"Scientists investigate that which already is;
Engineers create that which has never been."*

Goal of the project:

The project aims to design, fabricate and develop a combinatorial exploration system for optimization of microactuation using the sputtering technique of thin film compositional spreads.

Short description of the project:

The project has as main fundamental objectives the development of an exploration system that would allow:

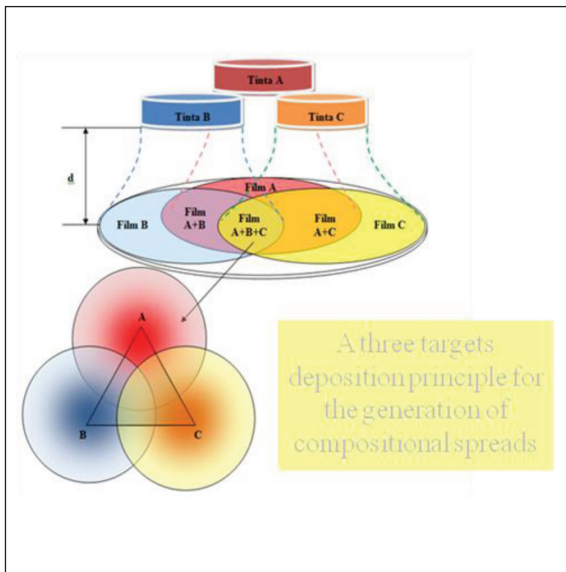

- a combinatorial optimization of actuation using the sputtering technique to generate compositional spreads;

- the development of models for combinatorial systems adapted for investigation of actuation;

- the implementation of the combinatorial exploration system for the case of intelligent materials, with focus on shape memory alloy families;

- the development of microactuators with controlled and optimized functionality;

- the investigation or modelling of systems for the exploration, and

- the microfabrication of materials with "on demand" properties, adapted for applications in microsystem engineering.

Project implemented by:

A research group of the Department of Materials and manufacturing Engineering of the "Politehnica" University of Timisoara

Implementation period: 2011-2014

Main activities:

Several experimental objectives have been defined:

- identification of specific design requirements for a system dedicated to generating combinatorial libraries of metallic materials;
- design of an exploration path for specific functionalities;

- design and fabrication of an exploratory system that allows sputtering of compositional spreads;
- design and microfabrication of substrates for the investigations of functional libraries;

- microfabrication of sputtered compositional spreads based on shape memory alloy compositions;
- microstructural-compositional characterization of libraries;

- design of an actuator based on thin film microfabrication.

The exploratory system aims to accelerate the innovation process in the fabrication of micro sensors and actuators.

"The best way to predict the future is to invent it"

Results:

A combinatorial deposition system was designed and is in the process of being finalized for the smart materials investigations.



A model for the prediction of actuation in bimorphs based on shape memory alloy films was identified.

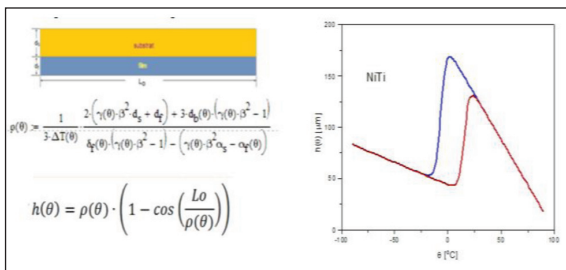

Substrates for deposition of thin films were manufactured by laser cutting.

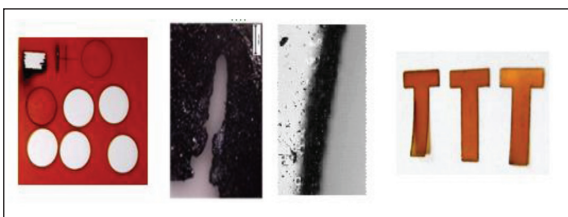

Fields of interest: Materials Engineering, Smart Sensors and Actuators, Micro and nanoengineering, Microsystems

Financed through/by:

Romanian National Authority for Scientific Research, grant CNCS – UEFISCDI, project number PN-II-ID-PCE-2011-3-0837

Research team:

Members and collaborators of the Department of materials and Manufacturing Engineering:

- Assoc. Prof. Corneliu M. Craciunescu
- Prof. Victor Budau
- Prof. Ion Mitelea
- Assoc. Prof. Aurel Ercuta

Research centre for Processing and Characterization of Advanced Materials

Aplicability and transferability of the results:

The output of the project is related to the development of a high-performance research instrument which will facilitate the initiation of accelerated innovation processes in the advanced functional materials field. Actuators like the ones for which the project develops an advanced R&D tool are expected increase the development of miniaturized products and expected to take over a variety of functions in microsystem dedicated to future aircraft, translating electronic or optical equipments.

Contact information:

Assoc. Prof. Corneliu M. Craciunescu
 Politehnica University of Timisoara
 Department of Materials Science
 Bd. Mihai Viteazul 1, 300222 Timisoara, Romania
 Tel: +40-256-403655, Fax: +40-256-403523
craciun@mec.upt.ro

“The best way to predict the future is to invent it”

Research centre for Processing and Characterisation of Advanced Materials

Goal of the project:

The main purpose of the project is to develop a class of specific composites based on aluminum and nanoparticles of aluminum oxides. These advanced cermets preserve their properties at high temperatures and are wear resistant.

Short description of the project:

This project aims to obtain new materials and advanced technologies with large applicability and with rapid development of this field. The parts obtained using these materials are of high class, given by their technical and economical performances. They also contribute to the reduction of environment pollution by low emanation of heat and combustion gases in the atmosphere.

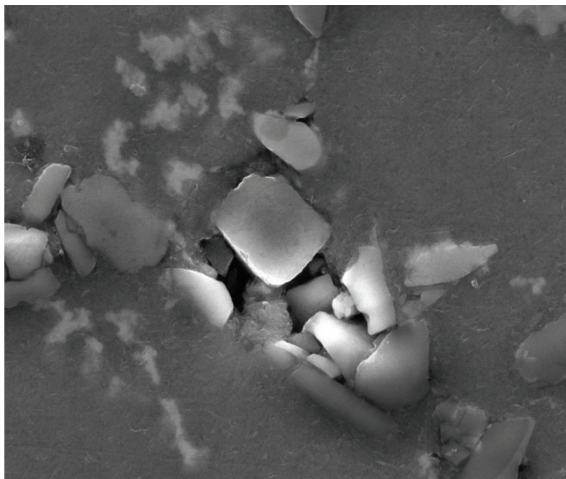

Typical digital image of a composite material, scanning electron microscopy, 5000x

Implementation period: 2012-2015

Project implemented by:

- SC ICPT TEHNOMAG CUG SA Cluj Napoca
- coordinator of the project, Politehnica University of Timisoara, Department for Materials Engineering and Fabrication
- Partner 1, SC TEHNOMAG SA Cluj Napoca
- Partner 2 and SC TEHNOEXPERT SRL Cluj Napoca – Partner 3

Main activities:

For the first stage of the project, the main activities include the analysis on the intergrain phenomena that take place in the morphology of the pores during reactive sintering of the composites.

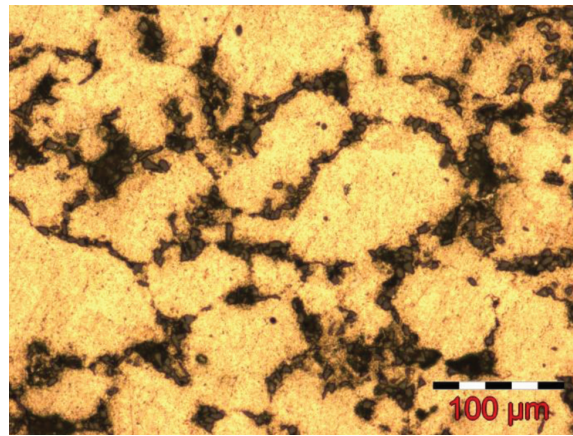

Digital image of a composite material with aluminum matrix, optical microscopy

Results:

- Study of the intergrain phase transformation at reactive sintering
- Study regarding the computer processing of morphologic modifications of pores and structure at reactive sintering
- Computer modelling of the morphologic transformation by diffusion at sintering.

“At every level the greatest obstacle to transforming the world is that we lack the clarity and imagination to conceive that it could be different”

Roberto Unger

- Characterization of the cermets properties related to pores morphology and compounds resulting at reactive sintering

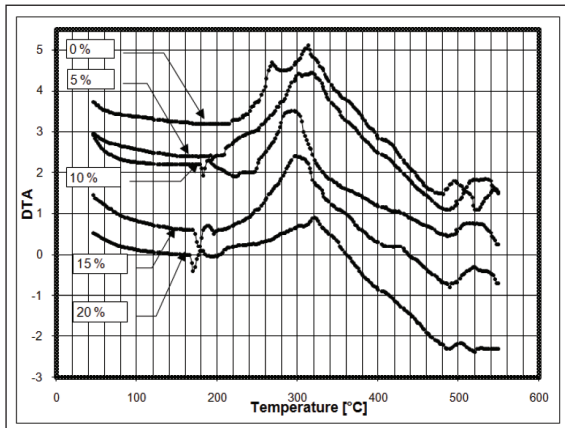

DTA curves at heating of Al-SiC cermet
(%SiC = 0..20% vol.)

The main goal achieved during the first stage of the project was to emphasize the methods for control and analysis of the intergrain phenomena and pore modification during sintering of the Al-Al₂O₃ cermets. The morphology of the pores (size, shape, characteristic dimensions, dimensional distribution) as well as the size and distribution of the compounds resulted after sintering were investigated by optical and scanning electronic microscopy (SEM).

The images obtained were afterwards computer processed to find all the details about this new class of materials.

A computer model of the morphologic transformations by diffusion at reactive sintering was also elaborated in this stage.

Fields of interest:

The main fields of interest connected with the project applicability and implementation

are: materials engineering, composite materials, environment protection.

Financed through/by:

UEFISCDI, PN II type project, Partnership in priority domains

Research team:

UPT team: Assoc. Prof. Dr. Eng. Mircea Nicoară, director of the project, Prof. Dr. Eng. Viorel-Aurel Șerban, Assoc. Prof. Dr. Eng. Aurel Răduță, Assist. dr. Cosmin Locovei, Assist. dr. eng. Carmen Opriș, Assist. Prof. Dr. Eng. Daniel Țunea, Assoc. Prof. Dr. Eng. Dănuț Șoșdean

SC ICPT TEHNOMAG CUG SA: Dr. eng. Gheorghe Tudor Șurdeanu - director

SC TEHNOMAG CUG SA:

Eng. Liviu Daianu - director

SC TEHNOEXPERT SRL:

Eng. Viorel Mureșan - director

Aplicability and transferability of the results:

The results obtained during the project will be transferred to companies in the field of automotive industry and will be presented on a web page accessible to all large public. Also, they will be presented during the AMS '13 *Advanced Materials and Structures* International Conference, a conference organized by the Department of Materials and Manufacturing Engineering from the Politehnica University of Timișoara.

Contact information:

Assoc. Prof. Dr. Eng. Mircea NICOARĂ
Department for Materials and Manufacturing Engineering

Address: 1 M. Viteazu Bvd, SPM building, 300222, Timișoara, Romania

Tel./Fax.: (0040) 256 403 626

E-mail: mnicoara@eng.upt.ro

mnicoara@gmail.com

"At every level the greatest obstacle to transforming the world is that we lack the clarity and imagination to conceive that it could be different"

Goal of the project: Cellular materials are widely used as cores in sandwich composites, for packing and cushioning. The main characteristics of foams are light weight, high porosity, high crushability and good energy absorption capacity. Present project propose to develop micro-mechanical models in order to predict the mechanical properties of cellular materials with a focus on modeling the fracture and the influence of damage on the mechanical response.

Short description of the project:

Project combines analytical methods, with numerical micro-mechanical finite element analysis and experimental investigations: materials testing and investigating the damage mechanisms by Digital Image Correlation and Thermoelastic Stress Analysis. The novelty of the project will be highlighted by the size and notch effect for cellular materials, and by investigating the effect of microstructural damage on the mechanical response of cellular materials.

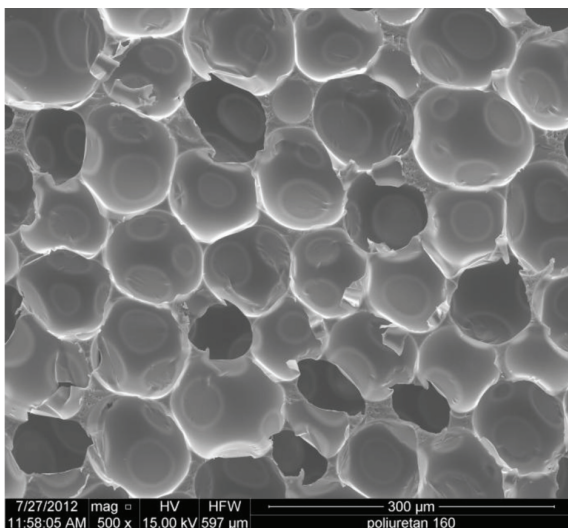

SEM microstructure for the 160 kg/m³ polyurethane foam

Main activities:

- Better understanding of mechanical behavior of cellular materials.
- Develop micro-mechanical models to estimate mechanical properties of cellular materials.
- Implementation of constitutive material models in Finite Element Analysis.
- Investigating the size effect and notch effect on cellular materials Evaluating the behavior of cellular materials under dynamic (impact and fatigue) loading.
- Identification of damage mechanisms in cellular materials.
- Investigating the effect of microstructural damage on the mechanical properties of cellular materials.

Research Centre for Processing and Characterization of Advanced Materials

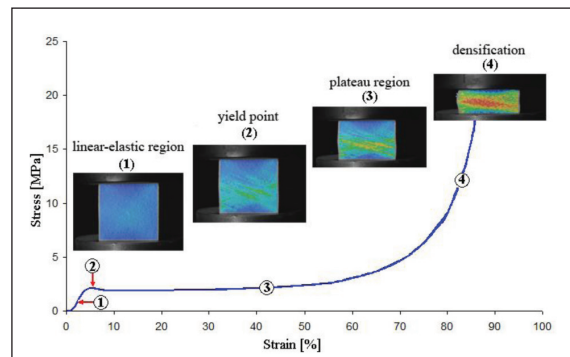

Strees – strain response and maximum principal strain field using Digital Image Correlation technique for 160 kg/m³ polyurethane foam under compression tests

Fields of interest:

- Composite and cellular materials
- Mechanical testing
- Finite Element Analysis
- Fracture and Damage Mechanics

Implementation period:

05.10.2011 – 04.10. 2014

“Somewhere, something incredible is waiting to be known.”

Dr. Carl Sagan

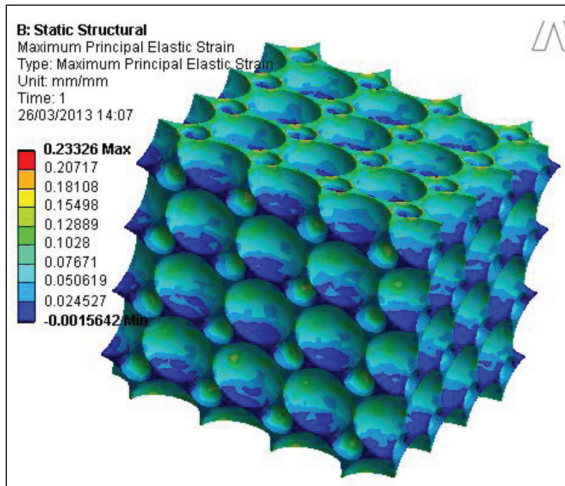

Finite Element maximum principal strain distribution for Representative Volume of foam

Results:

Journal Papers:

- Linul E., Marsavina L., Sadowski T., Kneć M., *Size Effect on Fracture Toughness of Rigid Polyurethane Foams*, Solid State Phenomena, Vol. 188, p. 205-210, 2012.
- Marsavina L., Linul E., Voiconi T., Sadowski T., *A Comparison Between Dynamic and Static fracture toughness of polyurethane foams*, Polymer Testing (OnLine First).

Conference Papers:

- Apostol D.A., Constantinescu D.M., Stoica M.O., *Modeling the influence of speed of testing and temperature on the behavior of polyurethane foams*, ECCM15 – 15th European Conference on Composite Materials, Venice, ITALIA, 24-28 June 2012.
- Marsavina L., Linul E., Sadowski T., Kneć M., Apostol D., Constantinescu D.M., *On fracture toughness of polyurethane foams*, 19th European Conference on Fracture, Kazan, RUSIA, 26-31 August 2012.
- Linul E., Marsavina L., Apostol D., Constantinescu D.M., Sadowski T., *Effect of density, loading rate, material orientation and temperature on dynamic compression behavior of rigid polyurethane foams*, FOAMS 2012, Barcelona, SPANIA, 12-13 September 2012.

- Apostol D.A., Constantinescu D.M., Linul E., Marsavina L., *Densification and energy efficiency of polyurethane foams*, Proceedings of the 29th Danubia-Adria-Symposium on Advances in Experimental Mechanics, Belgrade, SERBIA, 26-29 September 2012.

Research team:

- Prof. Dr. Eng. Liviu Marsavina – Project Manager
- Prof. Dr. Eng. Dan M. Constantinescu – Senior Researcher
- Dr. Eng. Emanoil Linul – Postdoctoral Researcher
- Dr. Eng. Cristian Nes – Postdoctoral Researcher
- Dr. Eng. Dragos A. Apostol – Postdoctoral Researcher
- Eng. Tudor Voiconi – PhD student
- Eng. Dan A. Serban – PhD student
- Eng. Florin Stuparu – PhD student

Research cooperation:

- Lublin University of Technology, Lublin, Poland
- Slovak Academy of Science, Bratislava, Slovakia
- Polymer Competence Centre Leoben, Austria

Aplicability and transferability of the results:

Results will be used by foams manufacturers Necumer and Spumotim to improve their technologies. Also, companies using foam components like TRW Automotive and Adidas will benefit by our developed micro-mechanical models to characterise their components and in the product design.

Contact information:

Prof. Dr. Eng. Liviu Marsavina
POLITEHNICA University of Timișoara
Faculty of Mechanical Engineering
Department Mechanics and Strength of Materials
Bv. M. Viteazu, Nr. 1, Timișoara 300222
ROMANIA

"Somewhere, something incredible is waiting to be known."

Dr. Carl Sagan

Goal of the project:

The project is oriented to the extension of performances of rotating seals and adaptive motion control devices to meet the requirements of several well-defined new applications, by high and very high magnetization sealing fluids and new type of magnetorheological fluids to be synthesized.

Short description of the project:

The project concept and objectives are illustrated schematically in figure below.

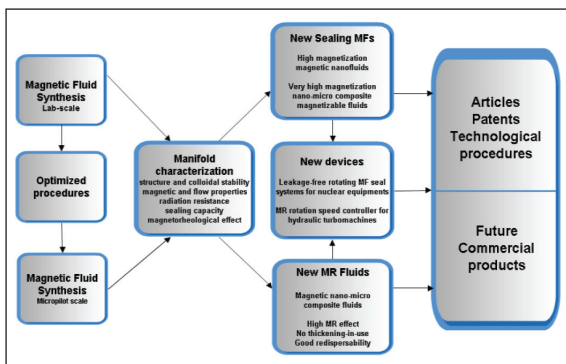

The workflow is organized along the following main directions: lab-scale and micropilot scale synthesis of high magnetization and radiation resistant magnetic nanofluids and nano-micro composite fluids for heavy duty (high pressure and/or rotation speed, contaminated medium) rotating seal and semi-active magnetorheological motion control applications; advanced structural, magnetic, rheological, magnetorheological characterization of the new magnetizable fluids; accelerated (irradiation) ageing and sealing capacity tests; design, manufacturing and experimental testing of leakage-free rotating seals for nuclear equipments and magnetorheological rotation speed controller devices for

hydraulic turbomachines. The new rotating seal and motion control systems for nuclear and hydraulic equipments offer better quality than usual solutions have, will help to gain new market shares and open technological advantages over traditional manufacturing routes. The seal systems proposed for nuclear equipments offer much higher level of environmental protection over traditional sealing units due to the leakage-free property of magnetic fluid rotating seals, increasing the commercial value of the solutions proposed.

Project implemented by:

Romanian Academy – Timisoara Branch (project coordinator), University „Politehnica” of Timisoara (partner 1), SC ROSEAL SA Odorheiu Secuiesc (partner 2) and National Institute for R&D in Electrical Engineering ICPE-CA Bucuresti (partner 3).

Implementation period:

July 23, 2012 – July 23, 2015

Main objectives of the *MagNanoMicroSeal* project are (O1) Synthesis and manifold characterization of magnetizable fluids for high pressure and heavy duty rotating seals and magnetorheological devices and, respectively, (O2) Design, fabrication and testing of leakage-free magnetofluidic rotating seal and magnetorheological(MR) control devices for well defined applications/ exploitation conditions.

Results:

The main results of this project refer to the elaboration of the following *technological procedures*:

- synthesis of high magnetization sealing fluids;
- synthesis of nano-micro structured magnetorheological fluids;

“No problem can be solved from the same level of consciousness that created it.”

Albert EINSTEIN

and qualification procedures:

- magnetic nanofluids for sealing applications in nuclear equipments;
- magnetic nanofluids for rotating seals for nuclear equipments.

The project results will be disseminated through publications in leading scientific journals, through presentations at national and international scientific meetings. Also, the involved procedures, technologies, devices and know-how are favourable for patent applications, as well as for development and exploitation by the industrial partner from the project.

The contributions of „Politehnica” University of Timisoara (Partner 1) to this project refer mainly to complex magnetic, rheological and magneto-rheological analyses of the magnetic sealing fluids and nano-micro structured magnetorheological fluids.

Fields of interest:

Physico-chemistry of magnetic nanoparticle synthesis; know-how and procedures for synthesis of over 50 types of magnetic nanofluids(MNFs) and nano-micro composite magnetizable fluids; accelerated ageing test procedures for organic compounds; magnetic, rheological, magneto-rheological and thermal investigation methods for the properties of magnetizable fluids; design and manufacturing of rotating seal devices; investigation of swirling flow phenomena and evaluation of effects on the performances of hydraulic turbomachines.

Financed by:

The Ministry of Education, Research, Youth and Sports (MECTS) - Executive Unit for Financing Higher Education, Research, Development and Innovation (UEFISCDI) through the PN II Program Partnerships in Priority Areas, *Collaborative applied research projects.*

Research team: the project research team consists of 43 researchers, engineers and technicians lead by **Dr. Ladislau VÉKÁS**, the director of the *MagNanoMicroSeal* project (Romanian Academy Timisoara Branch).

The „Politehnica” University of Timisoara (Partner 1) research team in this project consist of 6 researchers and 2 research assistants, as follows:

Assoc. Prof. Dr.-Eng. Floriana D. STOIAN, project responsible for Partner 1, Phys. Oana MARINICĂ, Assist. Prof. Dr. -Eng. Mat. Sorin HOLOTESCU, Assoc. Prof. Dr.-Eng. Nicolae CRAINIC, Assist. Prof. Dr. -Eng. Andreea DOBRA, Assist. Prof. Dr. -Eng. Adelina HAN, Res. Assist. Florica BĂLĂNEANU, Res. Assist. George GIULA.

Research centre: The research activities for „Politehnica” University of Timisoara (Partner 1) are carried out at the **Research Centre** for Engineering of Systems with Complex Fluids in the Magnetometry Laboratory, Rheology Laboratory and Numerical Simulation and Parallel Computing Laboratory.

Applicability and transferability of the results: The technological progress is strongly evidenced by future commercial products planned for the industrial partner SC ROSEAL SA: 16 new type of magnetically controllable fluids, 1 prototype and 3 functional models of magnetofluidic devices for nuclear and hydraulic power engineering.

Contact information:

Dr. Ladislau VÉKÁS

e-mail: vekas@acad-tim.tm.edu.ro
vekas.ladislau@gmail.com

Tel.: +40-256-403700;+40-256-403703;

Fax: +40-256-403700

Assoc. Prof. Dr. Eng. Floriana D. STOIAN

e-mail: floriana.stoian@mec.upt.ro
fdstoian@yahoo.com

Tel.: +40-256-403671;+40-256-403700;

Fax: +40-256-403700

“No problem can be solved from the same level of consciousness that created it.”

Albert EINSTEIN

Goal of the project:

The aim of the project is to parameterise some particular mechanisms of turbulent mass and momentum transfer that are likely to happen in specific urban forms named hereafter street-half-canyon. Another goal is to introduce that parameterisation in an existing air quality model used for regulatory purpose in France, SIRANE, so as to make this code able to address the question of industrial emissions in densely populated located directly around city centres, together with the validation of the new version of SIRANE with real life data provided by measurements taken in an urban environment submitted to industrial emissions. And also to install SIRANE in the city of Timisoara for air quality monitoring.

Short description of the project:

The team in Romania provides the data required for running the software and perform measurements for validation of the calculated data. Expected results include an environmental cadastre of emissions, including anthropogenic and natural pollution sources. Three dimensional maps of pollutant species concentrations would be available as a result of the research developed in this project. The new version of SIRANE developed during the project would allow decision factors to identify the most likely reason for exceeding imposed limits. Also, based on the results provided by this new tool, a better urban planning would be possible, so that a higher air quality can be ensured.

Project implemented by:

The department for Mechanic Machines, Equipment and Transportation from Politehnica University of Timisoara in partnership with Ecole Centrale de Lyon from France.

Main activities:

- parameterization of turbulent mechanisms responsible for pollution dispersion in specific urban forms;
- implementation of that parameterization in an existing urban air quality model;
- validation of the entire modeling chain by measurements in the city of Timisoara;
- quantification of uncertainty in the results resulting from the quality of the emission cadastre;
- development of a warning system that identifies episodes of exceeding imposed concentrations limits;
- development of improved urban planning strategies.

Results: a new dispersion model, new air quality monitoring tool for urban air quality, database containing pollutants concentrations.

Research team:

UPT team: Prof. Dr. Eng. Ioana IONEL, Assist. Prof. Dr. Eng. Luisa Izabel DUNGAN, Assist. Prof. Dr. Eng. Francisc POPESCU, Dr. Eng. Nicolae LONTIS, Dr. Eng. Ion VETRES, Dr. Eng. Adrian IRIMESCU, Dr. Phys. Delia CALINOIU, Dr. Eng. Catalin NISULESCU, Phys. Doina NICOLAE, Camelia TALIANU, Silviu MEGAN, Lavinia-Alina CALUSERU.

Research centre for Thermal Machines and Equipments, Transportation and Environmental Pollution Control

Contact information:

Prof. Dr. Eng. Ioana IONEL
Address: 1 M. Viteazu, 2nd floor, Timisoara
Phone/Fax: (0040) 256 403 670
E-mail: ioana.ionel@mec.upt.ro

"Our most basic common link is that we all inhabit this planet. We all breathe the same air."

John F. Kennedy

Goal of the project: The main objective of the project is to provide the newest development in SRC harvest technology. The ROD - PICKER system will be developed as an automatically working harvest, sorting and packaging system, thus greatly reducing the needed manpower and costs for harvesting SRC cutting in tree nursery quarters.

Short description of the project: Biomass is increasingly being seen as an important energy resource for Europe. However, due to sustainability requirements the biomass which can be harvested from European forests has only a limited growth potential.



Short-Rotation-Plantations are a very promising alternative source of income by cultivating fast growing tree-species as a source for bioenergy or other purposes with multifunctional characteristics. SRCs are highly efficient biomass production systems with additional environmental contributions such as biodiversity, soil protection and local climate.

Based on this background the SME proposers are planning to develop, construct and test an automatic harvesting and sorting system for SRC cuttings.

Research centre for Thermal Machines and Equipments, Transportation and Environmental Pollution Control

Implementation period: 2012 - 2014

Project implemented by: The department for Mechanic Machines, Equipment and Transportation from UPT in partnership with EGEDAL MASKINFABRIK A/S from Denmark (project coordinator), Salix Energi (Sweden), Lempe GbR (Germany), TU Dresden (Germany), TTZ Bremerhaven from Germany.

Main activities: Determination of technical and economic requirements for the ROD-PICKER system; Development and design of the ROD-PICKER prototype; Construction and testing of the ROD-PICKER prototype; On-site testing and optimization of the ROD-PICKER prototype at tree nursery farm, monitoring and evaluation; Assessment the effects on environmental, social and economic sustainability of the developed ROD-PICKER system.

Results:

- ROD-PICKER modules and units development;
- Prototype of new ROD-PICKER system;
- Prototype automatization and control unit;
- Testing results and final prototype.

Financed through/by:

European Union's Seventh Framework Programme managed by RES – Research Executive Agency.

Research team:

UPT team: Prof. Dr. Eng. Ioana IONEL, Prof. Dr. Eng. Dumitru TUCU, Prof. Dr. Eng. Sorin NANU, Assoc. Dr. Eng. Daniel DAN, and others.

Contact information:

Prof. Dr. Eng. Ioana IONEL
Address: 1 M. Viteazu, 2nd floor, Timisoara
Phone: (0040) 256 403 670
ioana.ionel@mec.upt.ro
<http://rod-picker.eu/>

"Energy and persistence conquer all things."

Benjamin Franklin

Goal of the project: protection of cultural regional heritage by means of a novel scientific tools consisting of identification of the pollution risk.

Short description of the project: Transboundary pollution is a natural phenomena, specific to vicinity regions, generated by national sources, under the influence of shared climate. The specific target regions (two counties) share the footprint of both nations and are of joint interest concerning raising the environmental awareness. The project demonstrates that a high level of environmental performance provides a long term competitive advantage, as it is focusing on establishing of the cross border pollution impact assessment versus the cultural & touristy natural heritage.

Project implemented by: The Department for Mechanic Machines, Equipment and Transportation from UPT in partnership with University of Szeged from Hungary and Diaspora Foundation from Romania.

Implementation period:
01.04.2012 - 31.03.2013

Main activities: Cultural, architectural & touristy sites identification in Timis/Csongrad area - identification and recording of important/relevant sites belonging of the cultural, architectural and touristy cross-border heritage; In-situ air quality monitoring campaigns in order to establish by direct pollutant concentration measurements (CO, NOx, SO2, O3, PM10 and VOC) the site air pollution and possible risks; Simulations/predictions of air pollutants impact on cultural/architectural/touristy sites.

Research centre for Thermal Machines and Equipments, Transportation and Environmental Pollution Control

Results: Action plan needed for both counties, Timis and Csongrád, and include cultural and architectural sites from both parts of the border; iso-concentration charts/maps were achieved for both counties, for the first time, including specific important sides on it, targeting the trans-boundary impact, as well of common interest.



Financed through/by: Hungary-Romania Cross-Border Co-operation Program 2007-2013 (www.hurocbc.eu) and is part-financed by the European Union through the European Regional Development Fund, Hungary and Romania.

Research team:

UPT team: Prof. Dr. Eng. Ioana IONEL, Prof. Dr. Eng. Sevastean-loan IANCA, Assist. Prof. Dr. Eng. Francisc POPESCU, Assist. Prof. Dr. Eng. Luisa Izabel DUNGAN, Assist. Dr. Olivia-Mihaela BUNDAU, Dr. Eng. Nicolae LONTIS, Dr. Eng. Ion VETRES, Eng. BRATEANU Gavril.

Contact information:

Prof. Dr. Eng. Ioana IONEL
Address: 1 M. Viteazu, 2nd floor, Timisoara
Phone/Fax: (0040) 256 403 670
E-mail: ioana.ionel@mec.upt.ro

"A people without the knowledge of their past history, origin and culture is like a tree without roots."

Marcus Garvey

Goal of the project:

The main idea of the project is to adapt a fuel delivery control system and reducing emissions for micro-cogeneration installations powered by spark ignition engines. In addition to the benefit of reducing pollutants regulated by law, specifically carbon monoxide, nitrogen oxides and unburned hydrocarbons, the use of biogas ensures a significant reduction of carbon dioxide emissions, a gas that even if its not considered to be toxic, contributes to the green house effect. A common problem for small size biogas installations is the inability to ensure a constant flow of gas and the same methane concentration.

Short description of the project:

The problem of emissions control is an important issue only for cogeneration systems over a certain power level. For natural gas or biogas fueled engines that power electric generators and feature exhaust gas heat recovery in micro-cogeneration installations, the quantity of pollutants expelled into the atmosphere is considered to be insignificant.

Nevertheless, a tendency to reduce emissions for small power installations is noticed. Also, given the advantages of distributed power generation compared to centralized systems, small size applications will increase in numbers. Another important issue in the near future is fuel availability, and fuel systems will be required to be capable of proper operation with a variety of fuel types.

For this reason, the lack of fuel must be compensated by employing a dual fuel system that ensures delivery of a liquid fuel such as gasoline, when biogas flow is too low. One of the objectives of the present project is to cover this aspect of dual fueling, with a multidisciplinary approach involving control systems engineering.

Project implemented by:

The Faculty of Mechanics

Implementation period: 2010-2013

Main activities:

- Informative study of scientific literature;
- Strategy development for a dual-fuel system;
- Control software development;
- Validation for control module operation and exhaust gas treatment system;
- Control strategy adaptation

Results: 15 Research Papers in national and international journals

Financed through/by:

UEFISCD - National Program PNII 2007 – 2013



Research team:

Nicolae LONTIȘ
Gavrilă TRIF-TORDAI
Adrian IRIMESCU
Cătălin NIȘULESCU

Research centre for Thermal Machines and Equipments, Transportation and Environmental Pollution Control

Aplicability and transferability of the results:

Co-generation whit biofuels, small scale cogeneration, isolated domestic housing.

Contact information:

Lontis Nicolae
Address: 1 M. Viteazu, 4th floor, 300222, Timișoara, Romania
e-mail: nicolae.lontis@mec.upt.ro
http://www.microkat.go.ro/index_en.htm
Phone: +40721605655

Goal of the project: The main objective of the project is to perform research and development activities in support of innovation in the field of biogas production. A major shift in the energy policy of both countries could only come from positive practices, together with best practices exchange. In order to reach this major objective, the partners will try to identify possible improvements of the biogas production in both liquid and solid phase.

Short description of the project: By the end of the project, the partners will have undertaken several joint research projects aiming at providing added value for the field. The goal is to connect technology, policy, industry, education, finance and public services in order to increase the understanding of the challenges brought

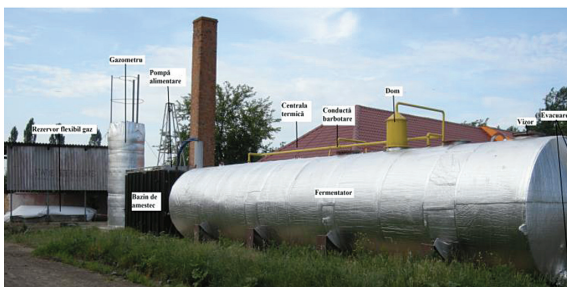

by the immense consume of energy, combined with the limited character of the resources. This can be an opportunity for fundamental change in the way the world produces and consumes energy. The synergy between the project partners has a multiplication effect on both sides of the border.

Implementation period:

01.06.2012-30.11.2013

Research centre for Thermal Machines and Equipments, Transportation and Environmental Pollution Control

Project implemented by: The department for mechanic machines, equipment and transportation from UPT in partnership with the University from Szeged, USAMVB Timisoara and Alapítvány Foundation from Szeged.

Main activities: Studies connected with fermentation of pre-treated and hydrolyzed biomass as way to increase the biomass conversion ratio and energy capitalization of biogas. Based on the previous detailed investigations appropriate suggestions will be made on the use and monitoring of the proper microbiological community to be employed for the anaerobic digestion of various organic waste substrates. Methods will be optimized and recommended for the characterization of the biogas production technologies from a microbiological point of view and interested users will be educated to carry out the necessary tests.



Recommendations will be formulated for the future advancement of the biogas biotechnology, such as the large scale production of the key microbes and enzymes to be employed. Integrated biogas technology descriptions will be provided for a number of applications such as the liquid phase anaerobic degradation of the treatment of solid organic household waste.

"At every level the greatest obstacle to transforming the world is that we lack the clarity and imagination to conceive that it could be different"

Roberto Unger

Results:

- Study regarding the energy capitalization of biogas
- Study regarding the existing technologies in the field of biogas production
- Testing different substrates at small scale and inside a pilot installation
- Report concerning the fermentation of pre-processed biogas
- Technological description of novel biogas improvement technologies



Some elements of the new technology developments will represent intellectual properties and will be protected accordingly. Other results of the joint scientific activity may belong to the public domain and will possibly be published in recognized international scientific journals by the Partners and will be presented at domestic and international conferences. Training in modern molecular biology techniques will be carried out on individual basis. There will be presented and disseminated the final results and conclusions over the undertaken activities and a final report will be delivered.

Fields of interest:

The main fields of interest connected with the project applicability and implementation are: biotechnology (analytical characterisation for the chosen substrates); overall characterisation of process in regards to anaerobic fermentation general parameters (temperature, pH, produced

quantities, partial composition of biogas in terms of methane and CO₂ percentages); ways of potentially optimize biogas production both in terms of the used materials and process control.

Financed through/by:

Hungary-Romania Cross-Border Co-operation Program 2007-2013 (www.hurocbc.eu) and is part-financed by the European Union through the European Regional Development Fund, Hungary and Romania, Action 2.2.2. Realization of joint research projects, contract id HURO/1001/193/2.2.2.

Research team:

UPT team: Prof. Dr. Eng. Ioana Ionel, Dr. Eng. Adrian Eugen Cioabla, Dr. Eng. Laurentiu Călin, Dr. Eng. Ramon Balogh, Dr. Eng. Daniel Bisorca, Dr. Eng. Delia Călinoiu.

USAMVB team: Assist. Prof. Dr. Vintila Teodor, Dr. Eng. Neo Simina.

Szeged University and Alapítvány Foundation from Szeged team: Prof. Dr. Kornél L. Kovács, Dr. Zoltán Bagi, Peter Heffner.

Applicability and transferability of the results:

The results obtained during the joint research project can be further tested and potentially applied (after thorough consideration) inside semi – industrial or low scale installations for determining the real potential of the different types of materials used for obtaining biogas.

Contact information:

Prof. Dr. Eng. Ioana IONEL

Address: 1 M. Viteazu, 4th floor, 300222, Timișoara, Romania

Tel./Fax.: (0040) 256 403 670

Mob.: (0040) 723 349 337

E-mail: ionel_monica@hotmail.com ioana ionel@mec.upt.ro

Web: <http://www.mec.upt.ro/resgas2011/>

“At every level the greatest obstacle to transforming the world is that we lack the clarity and imagination to conceive that it could be different”

Roberto Unger

Goal of the project:

The overall objective of the project is providing a reliable solution for substituting the fossil fuels used as energy sources for District Heating (DH) systems by sustainable and harmless alternatives through promotion and dissemination, aiming to set up new regional Short Rotation Coppice (SRC's) to DH chains.

Short description of the project:

Alternative sources of energy with potential enough for substituting fossil fuels are urgently required. Amongst all existent Renewable Energy Sources (RES), bioenergy is considered as the most promising source of sustainable and secure energy in Europe. Its availability is not a problem as in the fossil fuels case, and it is flexible enough to be applied to a wide range of services, being heating and cooling some of its most important applications.



As heating systems are the most energy consuming in Eastern European countries, the utilisation of biomass as combustible instead of fossil fuels would mean an important reduction in the emissions of these countries, which could significantly contribute to fulfil the EU targets. However, biomass-based RES are not currently being used as much as it would be desirable. Despite its potential, the lack of knowledge and know-how about its possibilities amongst other important barriers are hindering its use.

The project aims to promote the use of biomass from SRC's as a source of energy for DH systems in Central and Eastern European countries (concretely Czech Republic, Romania, Poland, Slovakia and Lithuania), showing potential future end users (DH professionals, established municipal energy suppliers and land owners) and stakeholders (local authorities or policy makers) the advantages of using biomass from SRC's as a source of energy and its applicability on DH systems.

Project implemented by:

The Department for Mechanic Machines, Equipment and Transportation from UPT in partnership with BIOAZUL S.L. from Spain (project coordinator), TTZ Bremerhaven (Germany), Czech Biomass Association (Czech Republic), Polish Association of Research and Applied Agriculture Specialists (Poland), Lithuanian Biomass Energy Association (Lithuania), Slovak Biomass Association (Slovakia), Lithuanian District Heating Association from Lithuania.

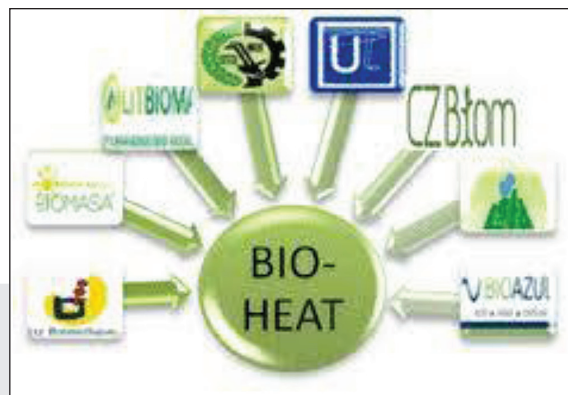

Implementation period:

01.09.2010 - 31.08.2012

"If you want to find the secrets of the universe, think in terms of energy, frequency and vibration."

Nikola Tesla

Main activities:

- Analysis of the state-of-the-art of DH applications, biomass and other RE sources used for energy supply;
- Identification of barriers for the extensive use of SRC`s as a source of energy for DH purposes;
- Compilation, review and socio-economical assessment of available success stories and best practices;
- Preparation of suitable training material and development of dissemination strategies;
- Organization of training workshops for DH plants managers, DH plants constructors and engineers, municipal energy suppliers, land owners and farmers and other professionals of the sector.
- Organization of training seminars for local and regional authorities and decision makers (banks, power plants financing and owners, sales organizations, SRC`s planners and consultants, etc.);
- Formation of SRC`s clusters in each country;
- Development of dissemination activities within the project duration and even once it ends.

Results:

- Development of suitable training and dissemination strategies according to the country addressed, adapting the strategy to the specific characteristics of each one;
- Raising awareness of potential end users and relevant stakeholders, leading to the creation of 5 new & working regional value-added chains on SRC`s in combination with DH applications.;
- Creation of dissemination material and translation of the items produced into the targeted countries language;
- Creation and maintenance of a project website, including a marketplace joining professionals of all involved sectors,
- a section for downloading the

project materials and other relevant documentation, information on other finished and on-going initiatives and on interesting events, a public forum, etc.

- Creation of energy clusters (at least one per target country, including sub-clusters for different target groups) by farmers and other professionals of the energy sector in order to establish closer collaboration between the energy production (DH, co-firing) and farming (SRCs growing) sectors.

Fields of interest: bioenergy, renewable energy sources, heating systems, biomass, energy clusters.

Financed through/by:

European Commission within its Intelligent Energy Europe (IEE) Programme.

Research team:

Prof. Dr. Eng. Ioana IONEL, Prof. Dr. Eng. Dumitru TUCU, Assoc. Dr. Eng. Dorin LELEA, Assist. Prof. Dr. Eng. Luisa Izabel DUNGAN, Assist. Prof. Dr. Eng. Virgil STOICA, Assist. Prof. Dr. Eng. Gelu PADURE, Assist. Prof. Dr. Eng. Francisc POPESCU, Asist. Dr. Eng. Gavrila TRIF-TORDAI, Asist. Dr. Eng. Dan STEPAN, Dr. Eng. Dumitru CEBRUCEAN, Eng. Gavrila BRATEANU.

Research centre for Thermal Machines and Equipments, Transportation and Environmental Pollution Control

Contact information:

Prof. Dr. Eng. Ioana IONEL
 Address: 1 M. Viteazu, 2nd floor,
 300222, Timisoara, Romania
 Phone/Fax: (0040) 256 403 670
 Mobile: (0040) 723 349 337
 E-mail: ionel_monica@hotmail.com
ioana.ionel@mec.upt.ro
 Web: <http://bio-heat.eu/>

"If you want to find the secrets of the universe, think in terms of energy, frequency and vibration."

Nikola Tesla

Goal of the project:

The project aims to discover the knowledge gaps of the students/graduates from the technical and economical universities in area of new business creation, entrepreneurial culture development based on learning through university-long education.

Short description of the project:

In 2010 “Politehnica” University of Timisoara and University of Ruse “Angel Kanchev” have started this bilateral project. This project had been initiated thanks to the membership of the two universities at RESITA net.

This project propose a contribution on economic competitiveness growth through development of a collaboration Romanian-Bulgarian between the two sides team for accomplishment of comparative studies to identify training needs for development of entrepreneurial skills and competences in the context of post integration in EU.

These will contribute to entrepreneurial education and culture development.

The methods of research was the phenomenology analysis and investigation based on questionnaires. The target group was undergraduate students (in terminal year), graduate students in master and PhD studies as well as graduate students employed in small and medium enterprises.

Based on the surveys there were done rapports with conclusions disseminated on the specific regional groups of interest.

The work program requested 18 months focuses on the surveys design and implementation for determining the training needs for entrepreneurs, and dissemination of the results.

Implementation period:

01.10.2010 - 31.03.2012

Project implemented by:

The Department of Management from University “Politehnica” Timisoara and Department of Business and Management from University of Ruse “Angel Kanchev”.

Main activities:

1. Research preparation
2. Meeting for project launching in both countries
3. Preparation and research instruments design
4. Lucrative meeting in both countries for questionnaire design validation and group target test
5. Surveys in both countries regarding the region of analysis
6. Questionnaires analysis in both countries
7. Lucrative meeting in both countries concerning results validation and comparative analysis
8. Profile formulation for entrepreneurial competences
9. Lucrative meeting for profile validation and preparation for dissemination of the project results
10. Writing of the publication for project results dissemination
11. Final meeting in both countries for project closing and establishing of further cooperation (done electronically)

Results:

Results of the project are: research rapports from each partner and joint rapports, conceptual models of research in specific research area, methodology for analyzing training and development needs for entrepreneurial skills.

“The entrepreneur always searches for change, responds to it, and exploits it as an opportunity.”

Peter F. Drucker

studies and analysis of regional interest, profile collection of entrepreneurial competences, questionnaire collection of entrepreneurial competences and of training needs evaluation in the region, scientific papers in ISI journals and conferences and in other international data-bases.

Fields of interest: The fields of interest were: training needs of entrepreneurship education and culture, higher education in the domain of engineering and management, at all levels (license, master and doctoral studies).

Research centre: Research Centre for Engineering and Management from UPT, and Ruse University Entrepreneurship Centre.

Financed through/by: Romanian National Authority for Scientific Research and the National Science Fund of Bulgaria.

Research team:

Romanian team: Tamasila Matei, Taucean Ilie Mihai, Pugna Adrian Pavel, Negru-Strauti Gabriela, Vacarescu Cella Flavia.



Bulgarian team: Pavlov Daniel, Ruskova Svilena, Todorova Milena, Gedinach Viktoriya, Enimaneva Svetoslava.

Aplicability and transferability of the results:

This profile of entrepreneurs resulted from the project is expected to enforce the efforts of both universities to provide a better training to their students as entrepreneurs,

and to improve the activities at both universities, related to entrepreneurship support.

For the University of Ruse, the analysis implemented within this project will have a direct effect on the activities organized by the Entrepreneurship Centre and the Department of Management and Business Development, such as:

- Improvement of the Master course in Entrepreneurship and Innovation;
- Improvement of the Bachelor courses in "Small business management" and "Entrepreneurship";
- Improvement of the relation "business-university";
- Support to students who seem to be "would-be-entrepreneurs";
- Development of new local, national and international projects related to entrepreneurship.

For "Politehnica" University of Timisoara, this analysis will affect the activities of Management Department and the Research Centre in "Engineering and Management", as follows:

- Improvement of the bachelor courses in the specialty of "Economic Engineering";
- Improvement of the master courses in "Entrepreneurial Management in Business Administration" and "Engineering and Management of Competitiveness";
- Improvement of doctoral courses related to entrepreneurship;
- A base for future projects related to entrepreneurship;
- Improvement of the relations between university and business environment, other universities, networks, and institutions involved in the entrepreneurial phenomenon.

Contact information:

Assist. Prof. Dr. Eng., Ec. Matei TĂMĂȘILĂ
Address: 1 M. Viteazu, SPM room 222D, Timișoara, Romania
Tel./Fax.: (0040) 256 404039
Mob.: (0040) 725 890 926
E-mail: matei.tamasila@mpt.upt.ro

"The entrepreneur always searches for change, responds to it, and exploits it as an opportunity."

Peter F. Drucker

Goal of the project: The objective of the project is to bring to the attention of structural engineers, manufacturers and contractors, the importance of initial imperfections and lateral restraints in the real behavior of the steel frame, in order to obtain well configured and erected steel structures and prevent component elements stability loss, an unacceptable aspect.

Short description of the project: Steel structures in form of members, plates and shells must frequently be investigated by advanced numerical methods, in order to take into account specific cases of loadings, boundary conditions, geometrical and material imperfections. The aim of the present research program is to find some answers to the following answer: What is more important, the shape or the size of the initial imperfection?



For this purpose parametric studies made by performant computer programs were used. Experimental tests were performed in the CEMSIG laboratory, in order to calibrate numerical models. The obtained results will be thereafter compared with the analytical ones, following the design methods/specifications of SR-EN1993-1-1.

Project implemented by: CEMSIG research Centre, Department of Steel Structures and Structural Mechanics, Politehnica University of Timisoara.

Implementation period:
01.09.2010-31.07.2013

Main activities: Imperfection influence study on isolated members with variable cross section (beams, columns) under combined bending and compression. The influence of different type lateral restraining on the element behavior - variable cross-section columns.

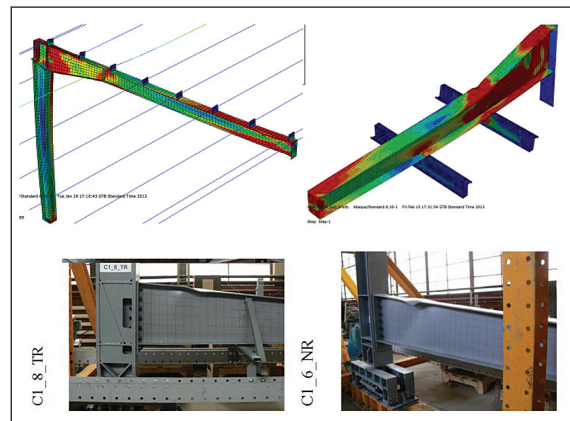

Imperfection influence study on single storey steel frames with slender elements under gravitational loading (permanent, technological and snow load) and extreme horizontal loading. Experimental testing of laterally restrained single storey steel frames. Calibration and parametrical study on the behavior of steel frames with elements of variable cross section.

Results: The out-of-plane buckling of the frame elements was noticed to be the main failure mode indifferent of the applied lateral restraints. There were cases for which the global lateral-torsional buckling of the frames was coupled with local buckling of the web. This was mainly observed when the restraints applied on the frame element are more effective against overall buckling (e.g. type 3 restraints). It was noticed that the considered imperfections has a low to significant influence on the final capacity of the frame, function of the applied lateral restraints.

"There are no secrets to success. It is the result of preparation, hard work, and learning from failure."

The difference between considered imperfections is significant mainly for the combined cases. The difference between elastic (actual) and rigid lateral restraints increases by the span increasing, a maximum 10 % difference was recorded.

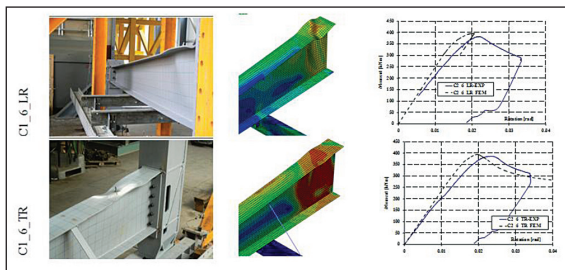

In what concerns the seismic behavior, even though the obtained behavior factor for type 1 and 2 lateral restraints characterizes the frames as low dissipative, this value can be improved significantly if more effective lateral restraints are applied.

The finite element modeling is reliable in predicting the ultimate capacity of the elements with tapered web under both compression and bending with sufficient accuracy.

From the experimental results - the restraining contribution from the purlins alone is reduced (their effect is small) for all specimen series. This might be explained by the small influence of the axial compressive force on the behaviour of beam-column elements with variable cross sections. The cross section twists rather than buckles laterally, due to the distribution of the normal stresses on the height of the cross section. The ultimate capacity can be improved by applying a supplementary restraining at the compressed flange, but this is only possible with the use of thicker web element (i.e. $t=8\text{mm}$).

Research Centre for Mechanics of Materials and Structural Safety- CEMSIG

Fields of interest:

The main field of interest, connected with the aim of the project, could be considered as follows: the stability and ductility of steel structures, design of steel structures, behavior of steel structures under extreme loadings, behavior of thin walled structured made of plated elements, reliability analysis of steel structures.

Financed through/by:

Ministry of Education, Research and Innovation. The National Authority for Science Research

Research team:

Phd. Eng, Senior Lecturer Mircea Cristutiu
Phd. Eng, Senior Lecturer Adrian Dogariu
Eng, Research assistant, Daniel Nunes
Phd. Eng, Assitant, Sorin Bordea

Applicability and transferability of the results:

The results obtained during the project emphasize in a more realistic manner the behavior of tapered elements, made of plated steel, when lateral restraints and initial imperfections apply. Besides this the actual design (not covered very clear by the codes) of these types of elements can be made accounting for all external influences and boundary conditions.

Contact information:

Phd. eng. Mircea CRISTUTIU
Senior lecturer
"Politehnica" University of Timisoara
Faculty of Architecture,
T. Lalescu Street, no 2
300223 Timisoara, ROMANIA
Fax: +40.361.814.159
Mobile: +40.723.281.859
E-mail: mircea.cristutiu@arh.upt.ro
www.arh.upt.ro

"There are no secrets to success. It is the result of preparation, hard work, and learning from failure."

Colin Powell

Goal of the project: The main objective of the project is to elaborate an improved methodology for investigating swirling flows stability using the mathematical analysis of hydrodynamic instabilities. The proposed methods are based on the application of stability and bifurcation analysis techniques in order to understand the dominant linear/ nonlinear instability of the swirling flows problems with applications in turbomachinery.

Short description of the project: The project approaches the fundamental problem of hydrodynamic stability of swirling flows. A large area of applications in problems of meteorological, aerodynamical or fluid dynamics significance has renewed the interest in the stability analysis of swirling, inviscid flows domain and the relation between the onset of vortex breakdown and hydrodynamic instability of the flow has been put under consideration. The occurrence of the precessing vortex and other instabilities in turbomachinery applications, address the mathematical modeling, the dynamic and stability of swirling flows, as well as the vortex breakdown phenomenon, which are all examples of fundamental problems in fluid dynamics.



We propose spectral methods based methodology that can be used for investigating classical questions addressed for swirling flows. Linear and non-linear stability theory offer a quantitative description of the flow behavior

when infinitesimal disturbances are superimposed on the basic flow.

Most fluid flows display either a growth in space or a complex spatio-temporal growth of disturbances. The main purpose is to conduct stability investigations based on the analysis of self-induced perturbations propagation in the swirling flow which will allow the recovery of the most relevant information using available computer resources in a very short time for a set of parameters.

Implementation period:
05.10.2011-04.10.2013

Project implemented by: The Department for Mathematics, University "Politehnica" of Timisoara, numerical data and equipment from National Centre for Engineering of Systems with Complex Fluids (NCESCF) (at University "Politehnica" of Timisoara).

Main activities: The main activities are adequate for the proposed objectives

- Analytical analysis of spectral methods for investigating the stability of the flow with a research on efficient implementations of linear solvers in the area
- Validate the results with data obtained by the experimental programs considered at NCESCF
- Actual application of the methods to problems triggered by swirling fluid dynamics
- Verification under industrially relevant conditions which will help in establishing the validity of the developed models

Results:

- Numerical results on the physical parameters values for the swirling flows problems with application in turbomachinery
- Numerical analysis for the eigenvalue problems governing the linear stability of swirling flows

- Convective/absolute instability analysis of swirling flows
- Extension of the 1D solver for solving columnar swirling flows to the 2D case.

The results were presented to international meetings on the subject and/ or published in international journals or proceedings:

1. Dijkstra, H. A., Wubs, F.W., Cliffe, A. K., Doedel, E., **Dragomirescu, F.I.**, Eckhardt, B., Gelfgat, A.Y., Hazel, A., Lucarini, V., Salinger, A.G., Phipps, E.T., Sanchez-Umbria, J., Schuttelaars, H., Tuckerman, L. S., Thiele, U., Numerical Bifurcation Methods and their Application to Fluid Dynamics: Analysis beyond Simulation, submitted to Communications in Computational Physics (submitted 24.09.2012)
2. **Dragomirescu, F. I.**, Efficient polynomials based method for a temporal stability investigation in a swirling flow stability problem, Proceedings 9th International Conference on Mathematical Problems in Engineering, Aerospace and Sciences (ICNPAA), Vienna University of Technology, Vienna, Austria, 10-14 Iulie, 2012, AIP Conf. Proc. 1493, pp. 322-329.
3. **Dragomirescu, F.I.**, Susan-Resiga, R., Muntean, S., On the Laguerre functions based Galerkin type method in a swirling flow stability problem with applications in turbomachinery, Proceedings of the conference Mathematical Models in Engineering Science, Paris, Dec. 2012, 228-233.
4. **Dragomirescu, F. I.**, Siddheshwar, P.G. Ene, R. D., Influence of micropolar parameters on the stability domain in a Rayleigh-Benard convection problem - A reliable numerical study, acceptat spre publicare in Italian Journal of Pure and Applied Mathematics, vol. 31, acceptat 16.06.2012.
5. **Dragomirescu, F. I.**, Moisa, I., On Convective/Absolute Instabilities Quantification in Swirling Flows in Turbomachinery, Proceedings of the 13th International Conference of Mathematics and its Applications ICMA2012, Timisoara, Noiembrie 2012, 211-216.
6. **Dragomirescu, F. I.**, Nonclassical polynomials based Galerkin formulation in a swirling flow stability problem, Proceedings of APLIMAT 2013, Bratislava, Feb. 5-7, 2013, p.17, 8 pages.

The conclusions and a final report will be delivered at the end of the project.

Fields of interest: The related physics problem is complex with important engineering applications. Solving of the problem using CFD techniques is challenging and time consuming. The approach of the problem using spectral method, which offers an alternative method can reveal important and complex physics and thus to improve engineering design in an efficient way. The researches of the project imply solving present days problems in turbomachinery hydrodynamics in order to understand fundamental aspects of the swirling flow hydrodynamic mechanisms so that one can chose the most efficient flow control method.

Financed by: Romanian National Authority for Scientific Research, CNCS - UEFISCDI, project number PN-II-RU-PD-2011-3-0153, 31/5.10.2011.

Research team: Assist. Prof. Dr. Florica Ioana Dragomirescu; Prof. Univ. Dr. Eng. Romeo Susan-Resiga

Aplicability and transferability of the results: The feasibility of the project is sustained by its significantly important engineering theme, with the results of importance for both applied mathematics and engineering. The main, and most important, goal is to explore the application of our methods modeling techniques to other applications involving simulation of fluid flow. The results are better designs, lower risk and faster time to the market place for these processes. Immediate applications within our research group include numerical stability results for analytical and discrete velocities profiles.

Contact information:

Assist. Prof. Dr. Ioana Dragomirescu
Address: Piata Victoriei, No. 2, 300006, Timișoara, Romania
Tel./Fax.: (0040) 256 403098
E-mail: ioana.dragomirescu@mat.upt.ro

UPT considers that scientific research is a priority of the university mission, conferring personality and distinction to the university, and that reaching excellence in scientific research is a target on medium and long term.

A series of inter-institutional collaborations have crucially influenced UPT's ranking in the 2011 classification exercise. Two main categories of institutional collaborations are to be noted: inter-university collaborations and collaborations with enterprises. Each of them has clearly established, mutually-shared objectives: mutual support, know-how transfer, and cooperation objectives for a common output.

UPT has always maintained a close relationship with the community, with the external environment, this relationship being its own reason to exist. Beyond the actual research and formal education, the research accomplished through technological transfer has been a constant concern for the University departments, faculties and management structures, which is reflected in the number of contracts with private companies.

This chapter presents the research contracts with third parties.

Field	Total number of projects
Computers and Information Technology	1
Energy Engineering	2
Electrical Engineering	2
Electronics and Telecommunication Engineering	2
Chemistry	1
Chemical Engineering	1
Materials Engineering	8
Mechanical Engineering	14
Management and Engineering	2

Goal of the project:

Design and implementation of new algorithms and techniques for incident and events detection in video sequences from surveillance cameras in retailer industry. Specific goal: detection and classification of non-scan events in conveyor belt till store configuration.

Short description of the project:



Fig. 1 Conveyor belt till configuration

Retail stores lose significant amount of money due to non-scan incidents at POS. These incidents have various causes like human intention (e.g. shoplifters) or unintended incidents (e.g. scan errors). Therefore huge benefits could be obtained from video analytics software ensuring automatic detection of these types of incidents. During this project we develop some novel algorithms that cover several cases for conveyor belt till configuration (fig. 1).

Project implemented by:

Department of Computer Science, Faculty of Automation and Computer Science

Implementation period:

January 2012- January 2013

Main activities:

Analyses and classification of non-scan POP events for conveyor belt till configuration. Developing techniques for cashier activities detection using specific image processing algorithms as background subtraction and optical flow. Design of algorithms for incident classification and events validation.

Results:

Algorithms for event detection and classification for conveyor belt till configuration in retail industry. These algorithms are used by the contractor in implementation of a novel solution for video analytics in retail industry.

Fields of interest:

Video processing, image processing, event classification.

Financed through/by:

Everseen Ltd., Ireland.

Research team:

Team leader: Assoc. Prof. Dr. Eng. Dan Pescaru
PhD Student: Assist. Eng. Ovidiu Parvu, PhD student
Diploma students: Dinu Seres, Caius Muresan

Research centre:

Research Centre for Computers and Information Technology

Applicability and transferability of the results:

Results are used on the market solution provided by Everseen Ltd, Ireland, which owns all commercial rights.

Contact information:

E-mail: dan@cs.upt.ro
Web: <http://www.cs.upt.ro/~dan/>

Goal of the project:

Verification of the conditions imposed on the impact of future photovoltaic power plants in normal operating conditions, over the distribution network operator in terms of maximum transfer capacity of network elements, respectively the voltage variation in the connection bus.

Short description of the project:

Information regarding the distribution network topology and power flow in the characteristic load days were processed using a dedicated software in order to analyse the power flow in normal operating conditions.

Project implemented by:

Department of Power Engineering, Faculty of Electrical and Power Engineering.

Implementation period:

June 2012- September 2012

Main activities:

Building database on the characteristics of medium voltage networks (20 kV) and high voltage (110 kV) involved their elements, their equivalent parameters and specific load conditions; simulating the normal operating conditions for the network areas affected by the future photovoltaic power plant, for characteristic loads; analysis in terms of requirements, drawing conclusions or recommendations on appropriate action for breach of restrictions.

Results:

Covaci photovoltaic power plant operation at maximum capacity does not lead to voltage variations in the network buses

below the limits of $\pm 5\%$, only pursuant to one of the following: construction of an individual 20 kV OHL or replacing the conductors in some sections of the 20 kV OHL with larger diameter wires. Both Covaci and Peciu Nou photovoltaic power plant operation don't cause the overlay of allowed limits for any of the network elements where will be connected.

Fields of interest:

Distribution electrical networks, photovoltaic power plants, distributed generation, normal operating conditions.

Financed through/by:

Research-developing and consulting contract no. 66/13.06.2012.

Research team:

Assoc. Prof. Dr. Eng. Adrian Pană – director,
Dr. Eng. Felicia Coroiu,
Assist. Dr. Eng. Alexandru Băloi,
Dr. Eng. Florin Molnar-Matei.

Research centre:

Research Centre for Power Systems Analysis and Optimization

Aplicability and transferability of the results:

The results of the study regarding the impact of build and operation of the two photovoltaic power plants over the distribution operator's network (Enel Distribuție Banat) were transferred to SC Cons Electrificarea Instal SRL Timisoara, general designer for both objectives.

Contact information:

E-mail: adrian.pana@et.upt.ro

Goal of the project:

Numerical testing of the lightning and overvoltage protection schemes within electrical substations; improving the protection schemes (case study – the 400 kV Mintia substation).

Short description of the project:

1st part refer to the lightning and overvoltage protection theoretical background. Also, the developed software tool is presented. 2nd part focuses on the existing overvoltage and lightning protection equipment testing. Finally, the conclusions and recommendations are synthesized for the 400 kV Mintia substation.

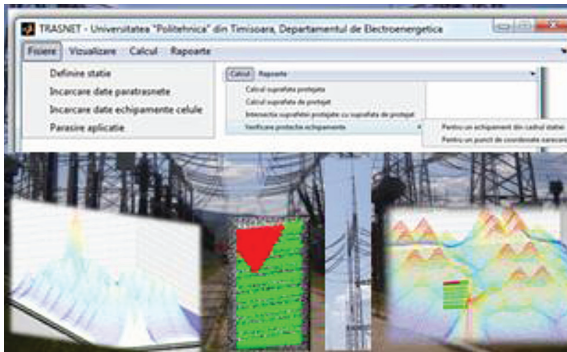

Project implemented by:

Romanian Power Grid Company
Transelectrica, Timisoara Subsidiary

Main activities:

- On-site situation confirmation and update;
- Dimension and location establishment for all the equipment (circuit breakers, disconnectors, insulators, conductors, surge arresters, current and voltage transformers) and protection elements (surge and lightning arresters, passive conductors);
- Software tool development and testing;
- 400 kV Mintia substation case study;
- Conclusions and recommendations on-site testing.

Implementation period:

October 2012 – June 2013

Results:

Software tool being able to be applied for the case of any electrical substation; application for the 400 kV Mintia substation.

Fields of interest:

Power system, electrical substation, overvoltage protection, lightning protection

Financed through/by:

Romanian Power Grid Company
Transelectrica

Research team:

Constantin BARBULESCU, Assist. Prof., PhD
Stefan KILYENI, Professor, PhD
Attila SIMO, PhD Student
Oana POP, PhD, Postdoctoral researcher
Razvan TESLOVAN, PhD Student
Antheia DEACU, PhD Student
Marcela LITCANU, PhD Student

Research centre:

Research Centre for Power Systems Analysis and Optimization

Applicability and transferability of the results:

The research work has been conducted for the 400 kV Mintia substation, Romanian Power Grid Company Transelectrica. The developed software tool and methodology is able to be applied in case of any electrical substation (Transelectrica, ENEL – Banat, Dobrogea, Muntenia, Electrica – Muntenia Nord, Transilvania Nord, Transilvania Sud, EON Romania, CEZ Romania).

Contact information:

E-mail: constantin.barbulescu@et.upt.ro
stefan.kilyeni@et.upt.ro

Goal of the project:

New single phase inverter configurations with reduced manufacturing costs, in particular through downsizing, with high efficiency power devices and cooling elements.

Short description of the project:

Conversion and storage through power electronics are the most important technological stages in renewable energy sources applications. In this field, the market competition is very aggressive, so all research efforts are oriented to obtain high efficiency at lower manufacturing costs. New circuit configurations, with multiple power inputs (for mixing more renewable energy sources), implemented with high performance power devices, are the specific ways in attending this goal. The project objectives were related to these aspects, completed with all necessary laboratory tests, including EMC.

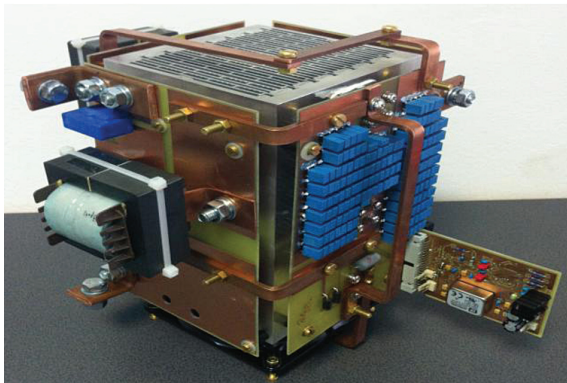

Project implemented by:

DIEHL GmbH, Germany.

Implementation period:

October 2012- present

Main activities:

- Design new, multiple input, power converter structure;

- Replacing the discret power components with high performance power IGBT module;
- Design and implement an adapted force cooling structure;
- Redesign and implement local filters in order to meet the EMC standard limits;
- Design a new shielded plastic cover in order to minimise the dimensions and weight;
- Extended performance and EMC tests.

Results:

New power converter configurations for renewable energy sources.

Fields of interest:

DC-DC, AC-DC, AC-AC static power conversion; Renewable energy conversion and storage control; Microgrids power converters and their control; Automotive power conversion systems.

Financed through/by:

DIEHL GmbH, Germany.

Research team:

Prof. Nicolae MUNTEAN, Ph.D.;
 Assoc. Prof. Octavian CORNEA, Ph.D.;
 Assoc. Prof. Cristian LASCU, Ph.D.;
 Assoc. Prof. Ciprian SORANDARU, Ph.D.

Research centre:

Research Centre for Smart Energy Conversion and Storage

Aplicability and transferability of the results:

Renewable energy and automotive industries.

Contact information:

E-mail: nicolae.muntean@ieee.org

Web: www.et.upt.ro

Goal of the project:

Within the framework of a stable and risk free energy delivery system, ensuring the required safety level for natural gas transmission pipelines can be achieved through appropriate maintenance procedures. An optimization of this activity can be obtained if careful planning of inspections and components replacement is employed. Risk based inspection can offer significant cost reductions compared to preventive maintenance and increased safety in operation compared to reactive strategies. Therefore, the projects aims to develop a risk analysis method and to evaluate its implementation in the conditions specified by the beneficiary.

the needs of the beneficiary and can be introduced in a seamless manner, in line with existing maintenance procedures.

Project implemented by:

Faculty of Mechanical Engineering

Implementation period:

June 2012– December 2012

Results:

An original method was developed for evaluating risk levels at natural gas pressure reduction stations, that can be applied even with a minimum set of input data, does not require experience in failure mode analysis, can be used independently and combined with a dedicated software. Inspection intervals that ensure high safety levels were identified and proposals were formulated for improving maintenance activities.

Fields of interest:

Energy

Financed by:

National Gas Transmission Company Transgaz S.A.

Research team:

Project manager: Ioan LAZA,
Team members: Viorel Aurel ȘERBAN, Carmen OPRÎȘ, Cosmin CODREAN, Andrei FERENCZ, Oana DULCA, Adrian IRIMESCU

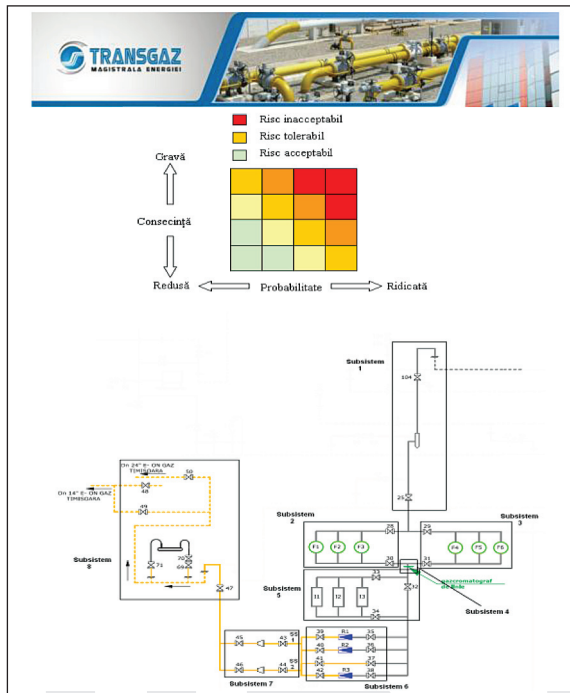

Short description of the project:

Rather than taking a turn-key solution approach and simply implementing an existing risk evaluation software, the project proposes the development of a methodology that is best suited to

Aplicability and transferability of the results: Application of the method in maintenance planning is foreseen in the near future.

Contact information:

E-mail: laza@mec.upt.ro, mmut@mec.upt.ro

Goal of the project:

Software development for a generic central display used in an advanced driver assistance system.

Short description of the project:

The project aims the design and implementation of a platform display which could be fast adapted to support different displays (size/resolution) having enhanced capabilities (24-bit colour depth / White Balancing). The solution is touch screen based having multifunctional interfaces. It also provides some degree of extensibility (other interfaces) and ability to run without additional intelligence (analogue wake up / dimming).



Project implemented by:

Continental Automotive
“Politehnica” University of Timisoara

Implementation period:

June 2012- October 2012

Research centre:

Research Centre for Intelligent Electronic Systems

Main activities:

Training in automotive embedded systems (Renesas V850E2 / Dx4 - JCP2011 microcontroller, OSEK, MISRA C)
Developing a touch screen application using Atmel maXTouch Technology

Results:

Driver implementation, using MISRA C compliant code, for an Atmel maXTouch touchscreen
Modules (dimming, CAN, LVDS) integration

Fields of interest:

Automotive embedded software
Automotive embedded hardware

Financed through/by:

S.C. CONTINENTAL AUTOMOTIVE ROMANIA S.R.L. TIMISOARA

Research team:

Dr. eng. Cătălin-Daniel CĂLEANU, Assoc. Prof.
Dr. eng. Georgiana SIMION, Assist. Prof.

Applicability and transferability of the results:

The project’s results have been transferred entirely and now are the property of Continental Automotive.

Contact information:

E-mail: marius.otesteanu@etc.upt.ro
catalin.caleanu@etc.upt.ro
georgiana.simion@etc.upt.ro

Goal of the project:

The project was focused on developing advanced automated testing strategies using LabVIEW and TestStand programming.

Short description of the project:

Specialists from Honeywell were trained in custom testing solutions in our facilities.

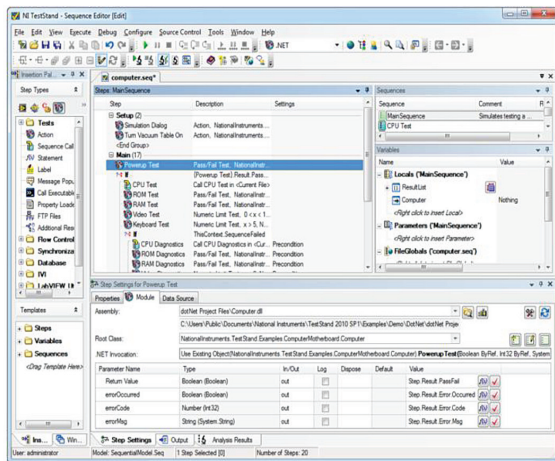

Project implemented by:

Honeywell Life Safety Romania

Implementation period:

November 2012 – December 2012

Main activities:

Developing solutions using LabVIEW, Teststand;

Results:

- Improved testing strategies
- Reduced test development time
- Custom testing solutions

Fields of interest:

- Automated testing
- Improved accuracy
- Overall cost reduction

Financed by:

Honeywell Life Safety Romania

Research team:

Aurel GONTEAN, Roland SZABO, Ioan LIE, Mircea BABAITA, Georgiana SIMION

Research centre:

Research Centre for Intelligent Electronic Systems

Applicability and transferability of the results:

Improvement of testing solutions

Contact information:

E-mail: aurel.gontean@etc.upt.ro

Web: <http://www.ccesi.etc.upt.ro>



Goal of the project:

The main goal of this project is to monitor nitrate and nitrite parameters from groundwater and a literature study regarding the technical solutions for their removal.

Short description of the project:

The quality of certain groundwater sources was assessed envisaging their use as drinking water source. Nitrate, nitrite and ammonium parameters were determined once per month during the period of one year as operational monitoring program to use these sources for drinking water in a potential area susceptible as vulnerable to nitrates. Also, several unitary processes suitable for the removal of nitrates, nitrites and ammonium were identified in order to elaborate a specific technology for drinking water treatment.

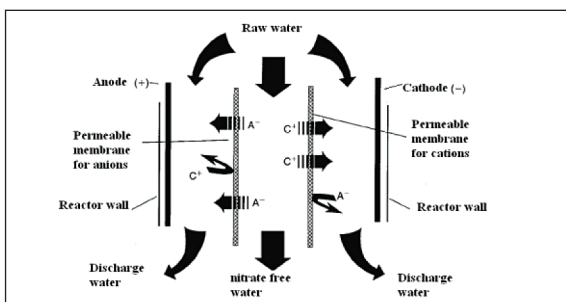

Example of electro dialysis membrane

Project implemented by:

SC. SECOM SA Drobeta-Turnu-Severin

Implementation period: 2013

Fields of interest:

Drinking water treatment

Main activities:

Monitoring of nitrate, nitrite and ammonia for certain groundwater sources selected from areas vulnerable to nitrate;

Literature study regarding the main unitary process for removal of nitrate, nitrite and ammonium

Results:

Assessment of groundwater quality from Mehedinti county

Technical solutions for removal of nitrate, nitrite and ammonium as data base for feasibility study to design the technological flow for drinking water treatment

Financed through/by:

SC. SECOM SA Drobeta-Turnu-Severin

Research team:

Assoc. Prof. dr. eng. Florica Manea-director
 Prof. dr. eng. Georgeta Burtica-member
 Dr. eng. Aniela Pop-member
 Eng. Sorina Motoc-member, PhD student
 Eng. Anamaria Baciu-member, PhD student

Research centre:

Research Centre for Environmental Science and Engineering

Aplicability and transferability of the results:

Water and sewage operators

Contact information:

E-mail: manea-florica.manea@chim.upt.ro

Goal of the project:

Conducting studies on physical and mechanical characteristics for polymers used in automotive.

Short description of the project:

Structural analysis, thermal analysis (TG, DSC, DMA), hardness measurements.

Project implemented by:

DURA AUTOMOTIVE ROMANIA SRL

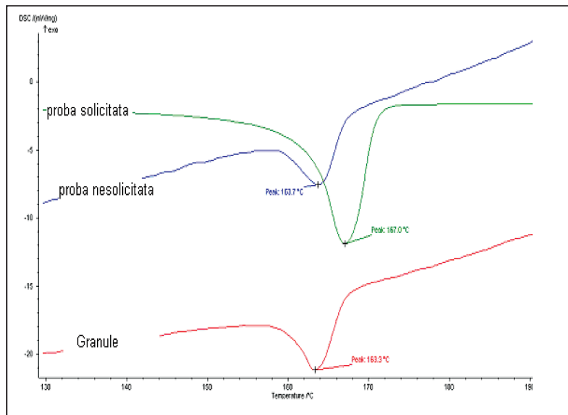

Implementation period:

July 2012- December 2012

analysis (TG, DSC, DMA), hardness measurements.

Main activities: Structural analysis, thermal

Results:

Resolving polymer structure, thermal stability and processing procedures.

Fields of interest:

Structural analysis, thermal analysis (TG, DSC, DMA), hardness measurements.

Financed through/by:

DURA AUTOMOTIVE ROMANIA SRL

Research team:

BANDUR Geza
RUSU Gerlinde

Research centre:

Research Centre for Organic, Macromolecular, and Natural Compounds, Chemistry and Engineering

Aplicability and transferability of the results:

Manufacture of polymeric materials.

Contact information:

E-mail: geza.bandur@chim.upt.ro

Goal of the project:

The goal of the project consisted in providing technical consultancy and preparing the Technical Project in order to finalize the execution process of a 200 mc water tank.

Short description of the project:

The execution of a 200 mc water tank in Răpsig village, Arad County, Romania was interrupted in an intermediate phase. The tower and the tank itself were executed, but the tank was never lifted to the designated elevation, on top of the tower.

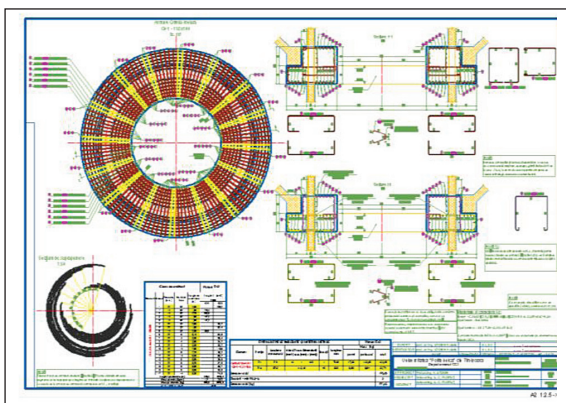

Thus, a Technical Expertise was conducted within 2011 in order to identify the viable solutions for completing the construction and building services works and to start operation of the tank in order to serve the community. Consequently, a Technical Project had to be prepared to provide detailed technical solutions, in accordance with the specifications and recommendations of the Technical Expertise.

Implementation period: 2012

Project implemented by: Faculty of Civil Engineering, Department of Civil Engineering and Equipments

Main activities:

Performance assessment of the structure and of various technical solutions for viable completion of intervention works and design of interventions on the reinforced concrete structure of the tower and of the tank.

Results:

The solution concept issued for structural completing the water tank proved sound and viable.

Fields of interest:

Civil Engineering
Behaviour and Design of Reinforced Concrete Special Structures

Financed through/by:

Water Company Arad

Research team:

Prof. Dr. Civ. Eng Valeriu STOIAN
Assist. Dr. Civ. Eng. Sorin-Codrut FLORUȚ
Cosmin POPESCU, MSc. Student
Eng. Simon PESCARI, Ph.D. Student

Applicability and transferability of the results:

The technical solutions provided within the framework of the current contract could be applied for any other similar situation.

Contact information:

E-mail: valeriu.stoian@ct.upt.ro
Web: <http://www.ct.upt.ro/centre/reco.htm>

Goal of the project:

The goal of the project consisted in performing structural health monitoring for two reinforced concrete chimneys.

Short description of the project:

The chimneys belong to the Rovinari Power Plant. After 30 years in service (around year 2000), the chimneys presented numerous large vertical cracks. They were strengthened and, in order to keep under observation the performance of the strengthening system, a Structural Health Monitoring Program was initiated. Since the main cause of the structural damages was the temperature gradient, it was settled to keep under strict supervision the exterior temperature of the chimneys.

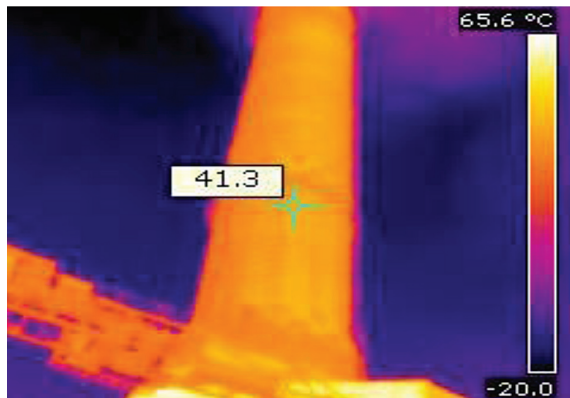

Project implemented by:

Faculty of Civil Engineering, Department of Civil Engineering and Equipments

Implementation period: 2012- 2013

Main activities:

Performing FE Analyses and conceive and implement the SHM program. Four intermediate site investigations and reports were performed, every three months.

Especially, measurements of exterior temperature distribution were carried out through thermograph procedure.

Results:

The monitoring program enabled the structural expert and the client to keep under real-time observation the condition of the two structures, enabling them to be kept further in use.

Fields of interest:

Civil Engineering
Structural Health Monitoring
Long time performance and behaviour of reinforced Concrete Special Structures

Financed through/by:

Energy Complex Oltenia, Branch Electrocentrale Rovinari

Research team:

Prof., Dr. Civ. Eng. Valeriu STOIAN
Assoc. Prof. Dr. Civ. Eng. Daniel DAN
Assist. Prof. Dr. Civ. Eng. Sorin-Codrut FLORUȚ
Eng. Simon PESCARI, PhD Student

Research centre:

Research Centre for Retrofitting of Constructions

Applicability and transferability of the results:

The technical solutions provided within the framework of the current contract could be applied for any other similar situation.

Contact information:

E-mail: valeriu.stoian@ct.upt.ro
Web: <http://www.ct.upt.ro/centre/reco.htm>

Goal of the project: Hydraulic calculation of irrigation canal closure (Water conveyance structure I) c metal structure of corrugated steel sheet that can support the load.

Short description of the project: Investments Butterfly Park & Golf - Golf and Leisure found that it is crossed by irrigation canal Fântânele - Sag, reason for which the hydraulic study on closing (intubation) its metallic structure of corrugated steel sheet that can support the load of future traffic of the golf course.

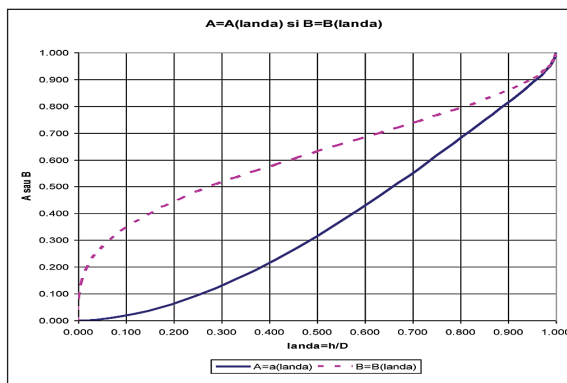

Project implemented by:

Faculty of Civil Engineering, Department of Hydrotechnical Engineering

Implementation period:

February 2012- August 2012

Main activities:

Determination of transport capacity of water conveyance structure I.
Study the possibility of intubation CA I channel of 2.9 km in the following variants:
• metal structure of corrugated steel sheet, circular section with a diameter of D-1400 mm to D-4000 mm; - with high density

polyethylene pipe (HDPE) D-2000 mm to D-2800 mm;

•metal structure of corrugated steel sheet: 2 pipes of 2100 mm, 1 pipe of 3000 mm and 1 of 3100 mm, 1 pipe of 4000 mm, 2 pipes of 2200 mm, 1 pipe of 2000 mm and 1 of 2300 mm, 2 pipes of 2800 mm
For all these variants were prepared curves $Q=Q(h)$, $A=A(\lambda)$, $B=b(\lambda)$.

Results: The study revealed the need to use pipes with small roughness (smaller than the existing channel) Example: HDPE pipe version, PREMO, PAFSIM, etc.

Fields of interest: Design the optimal hydraulic structures

Financed through/by:

The company S.C.TUBO TRADE PROIECT S.R.L.

Research team:

Prof. Dr. Eng. Man Teodor Eugen
Assist. Prof. Dr. Eng. Beilicci Robert Florin
Assist. Dr. Eng. Hălbac-Cotoară-Zamfir Rareș
Secretary Nistor Alexandra

Research centre:

Research Centre for Hidrotechnics

Aplicability and transferability of the results:

Efficient design of technical and economic solutions intubation water conveyance structure CA I from irrigation system Sagu-Fântânele-Arad on the area where it crosses the golf course "Butterfly" Park & Golf.

Contact information:

E-mail: eugen@zavoi.ro

Goal of the project:

Establish the influence of the weld upon the lifetime of the pipe crossing subset from a gas supply system

Short description of the project:

The project analyzed the behavior of the pipe crossing subset in corrosive environment compared with the joining of the parts without using weldEng.



Project implemented by:

S.C. MMG S.R.L. located in Baia Mare, Romania

Implementation period:

August 2012 – September 2012

Main activities:

The activities developed for the project included:

- comparative analysis of design solutions;
- establish of the factors that can influence the corrosion behaviour of the pipe crossing part;
- assessment by calculus of the lifetime of the part in both design variants;
- experimental study of the parts behaviour in corrosive environments;

- metallographic analysis of the potential harmful sections for both constructive designs.

Results:

Experimental and analytic estimation of the life cycle of the studied part; the study conducted established that the lifetime of the examined parts is lower than 50 years, which is the lifetime recommended by the normatives

Fields of interest:

Materials science, corrosion, failure analysis

Financed through/by:

S.C. MMG S.R.L. located in Baia Mare, Romania

Research team:

Assoc. Prof. Dr. Eng. Aurel Răduță, director of the project, Assoc. Prof. Dr. Eng. Mircea Nicoară, Assist. dr. Cosmin Locovei

Research centre:

Research Centre for Processing and Characterisation of Advanced Materials

Aplicability and transferability of the results:

The company intends to improve the constructive solutions and to study furthermore in cooperation with the Politehnica University of Timisoara the possibility of testing the corrosion degree in service of the pipe crossing part.

Contact information:

E-mail: aurel.raduta@mec.upt.ro

Goal of the project:

The project goal was to obtain ferroalloys powders that can be used in thermal spraying techniques.

Short description of the project:

The project consisted in realizing ferroalloys powders having dimensions ranging between 15 – 45 µm, like ferroborrow, ferrosilicon, ferromolybdenum, ferrophosphorus and chromium and iron powders.

Project implemented by: ISIM Timișoara

Implementation period:

October 2012– November 2012

Main activities:

The main activity during the project was to optimize the chemical composition of the ferroalloys and to obtain the powders at the requested dimensions.

Results:

Ferroalloys powders for thermal spraying processes

Fields of interest:

Thermal spraying process

Financed through/by: ISIM Timișoara

Research team:

Codrean Cosmin, Opreș Carmen, Uțu Dragoș

Research centre:

Research Centre for Processing and Characterization of Advanced Materials

Aplicability and transferability of the results:

Obtaining coatings with high mechanical properties and good corrosion resistance through thermal spraying technique.

Contact information:

E-mail: cosmin.codrean@mec.upt.ro

Goal of the project:

The project goal was to design patterns for cutting leather used for dressing steering wheels in order to increase productivity and profitability.

Short description of the project:

The project consisted in creating a 2D model of the patterns used for cutting leather which can be linked to a sewing machine, so that the process of cutting leather can be automated.

Project implemented by:

TRW Automotive

Implementation period:

October 2012– November 2012

Main activities:

The main activity during the project was to realize the 2D models using CAD software for the patterns used depending on the shape of the steering wheel.

Results:

2D – CAD models for patterns that can be linked to a sewing machine.

Fields of interest: Automotive

Financed through/by: TRW Automotive

Research team:

Codrean Cosmin, Opreș Carmen, Uțu Dragoș

Research centre:

Research Centre for Processing and Characterization of Advanced Materials

Aplicability and transferability of the results:

The technical documentation of this project allows the implementation in each TRW factory all over the world.

Contact information:

e-mail: cosmin.codrean@mec.upt.ro

Goal of the project:

The project goal was to upgrade the TRW working stations for dressing steering wheels in order to increase productivity and profitability.

Short description of the project:

The project consisted in designing a working cell for dressing steering wheels which included one positioning, three sewing, one finishing and one drying workstations, two carts (one for undressed and one for finished steering wheels) and a board to keep track.

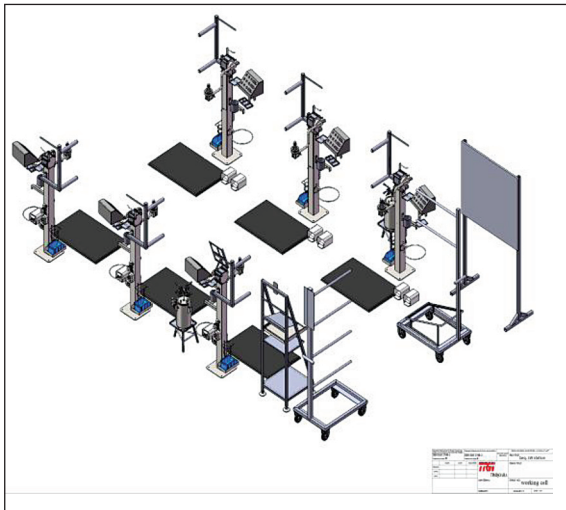

Project implemented by:

TRW Automotive

Implementation period:

June 2012– July 2012

Main activities:

The main activity during the project was to design using CAD software each workstation and their accessories and to select the optimal materials.

Results:

An optimal working cell for dressing steering wheels.

Fields of interest:

Automotive industry

Financed by:

TRW Automotive

Research team:

Codrean Cosmin
Opriș Carmen
Uțu Dragoș
Cioană Cristian

Research centre:

Research Centre for Processing and Characterization of Advanced Materials

Applicability and transferability of the results:

The technical documentation of this project allows the implementation of this working cell in each TRW factory all over the world.

Contact information:

E-mail: cosmin.codrean@mec.upt.ro

Goal of the project:

To improve the quality and dimensional accuracy of injected plastic parts used, especially, in the automotive industry.

Short description of the project:

In this research the 3D inspection of the injected plastic parts has done on a CMM with contact sensors.

For each plastic parts studied, used in the automotive industry, is developed its own strategy for measuring according to the characteristics of the part, shape, accuracy and the quality of the real part.

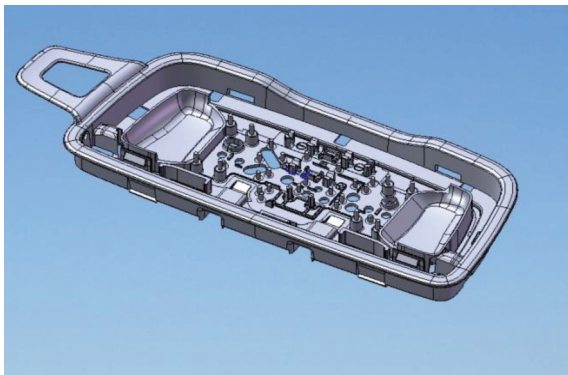

Project implemented by:

S.C. Elbromplast S.A. Timișoara, Romania

Implementation period:

July 2012– July 2013

Main activities:

- study the real plastic parts and their drawings;
- 3D measuring program conception;
- 3D measure of the plastic parts;
- analysing the measuring results;
- interpretation of the results and conclusions.

Results:

Different types of plastic parts regarding the dimensions, shape and accuracy. For each plastic part studied were formulated conclusions regarding the actual dimensions and shape.

Fields of interest:

3D measuring on Coordinate Measuring Machines, mold design, injection process, quality assurance for plastic parts used in the automotive industry and for different other plastic parts.

Financed through/by:

S.C. Elbromplast S.A. Timișoara, Romania

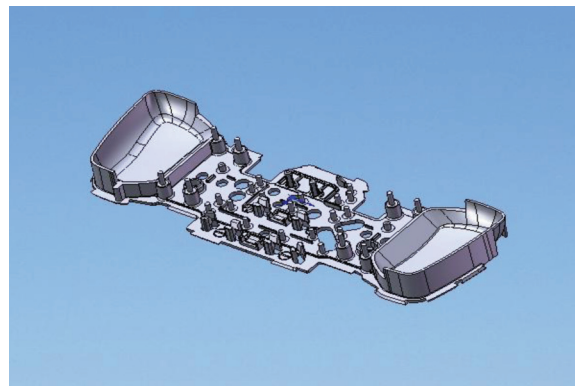

Research team:

Assoc. Prof. Dr. Eng. Tulcan Aurel
 Assoc. Prof. Dr. Eng. Stan Daniel
 Assist. Prof. Dr. Eng. Tulcan Liliana

Research centre:

Research Centre for Integrated Engineering

Aplicability and transferability of the results:

All the research results are transfered to the company. Based on these results, in the mold testing phase, some corrections at the injection mold can be made. During the part production period the results could be used to change the injection process parameters in order to fit the part in the technical specifications.

Contact information:

Email: atulcan@eng.upt.ro
dstan@eng.upt.ro
liliana.tulcan@mec.upt.ro

Goal of the project:

The determination of stress-strain characteristics for type 170AL0/28 MEHST aluminum-steel electrical conductors, designed for high-voltage aerial transportation lines.

Short description of the project:

The project consists of experimental determination of stress-strain characteristics of aluminum-steel conductors. The conductors are subjected to uniaxial traction. The test specimen's length is 11 m. First, the UTS is determined, then the stress-strain curve is constructed.

Project implemented by:

„Politehnica” University of Timișoara and ICME ECAB S.A. București

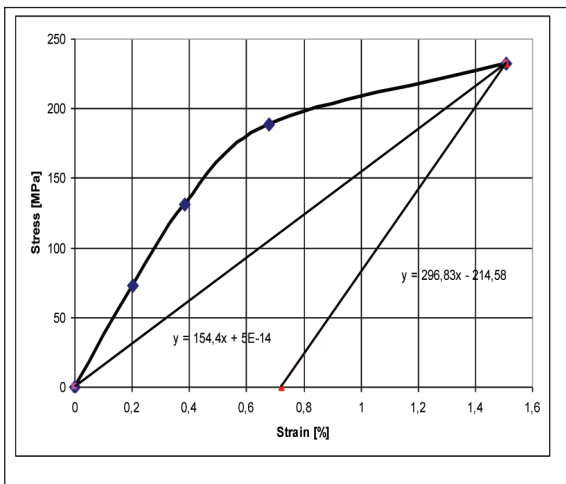

Implementation period:

March 2012– March 2013

Main activities:

First, the test specimens must be prepared. They must be cut to size and installed. The UTS is then determined. After validating the conductor's Ultimate Tensile Strength (UTS), a special test is performed (called stress-strain test). The test simulates the

strain accumulated during the life span of the conductor. The results must be evaluated and the stress-strain curve can be constructed. The total strain could not be determined (the elongation was larger than the testing machine's travel). For the same reason, the Young's modulus was smaller than the one prescribed in the normative.

Results:

The results showed excessive deformations under load. Furthermore, although the UTS was bigger than the minimal value presented in the standard, the total strain could not be determined (the elongation was larger than the testing machine's travel). For the same reason, the Young's modulus was smaller than the one prescribed in the normative.

Fields of interest:

Electrical conductor manufacturing and testing, high-voltage transportation lines.

Financed through/by:

ICME ECAB S.A. București.

Research team:

Dr. Eng. Cristian-Sorin Neș (head of project);
 Dr. Eng. Anghel Cernescu;
 Dr. Eng. Emanoil Linul;
 Ph.D. Stud. Lorand Kun;
 Ph.D. Stud. Lucian Bogdan.

Research centre:

Research Centre for Processing and Characterization of Advanced Materials

Applicability and transferability of the results:

The tests were performed in order to certify a new product of ICME ECAB. The results are used for the improvement and development of the new product.

Contact information:

E-mail: cristian.nes@mec.upt.ro

Goal of the project:

The determination of stress-strain characteristics for type TA2X (FL)2Y-OL aluminum and steel electrical conductors, designed for high-voltage aerial transportation lines.

Short description of the project:

The project consists of experimental determinations of stress-strain characteristics of aluminum and steel components of the conductors. The conductors are subjected to uniaxial traction. The test specimen's length is 11 m.



Project implemented by:

„Politehnica” University of Timișoara and S.C. PRYSMIAN Cabluri și Sisteme S.A. Slatina.

Implementation period:

July 2012– July 2013

Main activities:

First, the test specimens must be prepared. They must be cut to size and installed. The UTS and the elongation to break are

then determined and validated. The tests were performed both on the aluminum conductors and the steel support wire.

The results were combined and used for the global evaluation of the whole composite cable (consisting of 3 aluminum conductors and 1 steel support wire).

Results:

The tests produced excellent results for both the aluminum and the steel cables, which certificate the good quality of the cable and conformity with the normatives.

Fields of interest:

Electrical conductor manufacturing and testing, high-voltage transportation lines.

Financed through/by:

S.C. PRYSMIAN Cabluri și Sisteme S.A. Slatina

Research team:

Dr. Eng. Cristian-Sorin Neș (head of project);
Dr. Eng. Emanoil Linul;
Ph.D. Stud. Lorand Kun;
Ph.D. Stud. Lucian Bogdan;
Ph.D. Stud. Sergiu Galatanu;
Ph.D. Stud. Mihaela Amarandei.

Research centre:

Research Centre for Processing and Characterization of Advanced Materials

Applicability and transferability of the results:

The tests were performed in order to certify a new product of S.C. PRYSMIAN Cables and Systems S.A. Slatina.

Contact information:

E-mail: cristian.nes@mec.upt.ro

Goal of the project:

The project had two main objectives:

- Determination of the quality characteristics of refractory products used in steel industry;
- Statistical analysis and modeling of the quality characteristics of refractory products.

Short description of the project:

The refractory materials used in steel are in a wide range, both in terms of chemical composition and geometric shapes. Thus it is interesting to establish the interdependency relations of chemical and physical, thermal properties of the refractory products on the behavior of qualitative in the industrial practice.

Project implemented by:

Faculty of Engineering of Hunedoara

Implementation period:

September 2012- December 2012

Main activities:

- Determination of the quality characteristics of refractory products;
- The substantiating of solutions of the material on the use of refractory products in steel industry;
- Implementing the program using the Matlab software, to determine statistical analysis of parameters involved in the analysis of refractory products.

Results:

The program enable determination of the optimal variation of the parameters analyzed (the chemical and physical, thermal proprieties).

Fields of interest:

Steel industry
Refractory products

Financed through/by:

S.C. Centre for research, design and production refractory S.A , Alba Iulia, Al. I. Cuza Str., No. 23, Alba

Research team:

Assistant Professor PhD Stoica Diana, Associate Professor PhD Socalici Ana Virginia, Assistant Professor Lemle Dan

Research centre:

Research Centre for Processing and Characterization of Advanced Materials

Aplicability and transferability of the results:

The results were delivered to the beneficiary and are implemented in practice in the Centre for research, design and production refractory, Alba Iulia, (in micro-production hall).

Contact information:

E-mail: stoica.diana@fh.upt.ro



Goal of the project:

Determination of gaseous and solid pollutants resulted from production, in special points.

Short description of the project:

The product of the research activity for the client is the measurements on line & conceiving of an appropriate resulted analysis report. The quality of this report is given by the quality of the recorded information and accuracy of the used instruments, all having metrological control and working according standardized EU procedures. For this reason, the precision of the experimental data as being an important requirement is achieved. The accuracy of the report is based on indicated precision and errors. The instruments used for measurements are: TESTA FID 123, STROHLEIN STE4 analyzer and TESTO 350XL analyzer.



TESTA FID 123 analyzer

Project implemented by:

LaCIEDiN - Laboratory for Fuel Analyses, Ecological Investigations and Pollutant Dispersion

Implementation period:

April 2012- April 2013

Main activities:

Project steps: measurements in situ / phase, results processing, data interpretation and preparation of analysis bulletin/report.

Results:

- Particles concentrations;
- NO, NO₂ and NO_x concentrations;
- VOC concentrations from gaseous effluent; indicated as TOC (from emission).

Fields of interest:

The LaCIEDiN-Laboratory acts according standard SR EN ISO/CEI 17025:2005 and it is RENAR accredited with certificate no. LI 787 from 22.06.2009.

Financed through/by:

S.C. ALU METALL GUSS SRL

Research team:

Prof. dr. eng. Ioana Ionel, Assist. Prof. dr. eng. Francisc Popescu, Dr. eng. Nicolae Lontis, Assist. Prof. dr. eng. Luisa Dungan, Assist. dr. eng. Gavrilă Trif – Tordai

Research centre:

Research Centre for Thermal Machines and Equipments, Transportation and Environmental Pollution Control

Applicability and transferability of the results:

On customer request, results are confidential.

Contact information:

E-mail: ioana.ionel@mec.upt.ro
Web: <http://mettcp.mec.upt.ro/>

Goal of the project:

Determination of pollutant emissions from exhaust stacks and air quality in the vicinity for particles concentration.

Short description of the project:

The product of the research activity for the client consists of several on line measuring campaigns and conceiving in accordance of this representative data basis of an analysis report. The quality of this report is given by the quality of the information it contains. For this reason, the precision of the experimental data is an important requirement. The accuracy of the report is based on this precision. The instruments used for measurements are: STROHLEIN STE4 analyzer and LSV3 analyzer.



STROHLEIN STE4 analyzer

Project implemented by:

LaCIEDiN - Laboratory for Fuel Analyses, Ecological Investigations and Pollutant Dispersion

Implementation period:

February 2012- December 2012

Main activities:

Project steps: measurements in situ / phase, results processing, data interpretation and preparation of analysis bulletin/report.

Results:

- Particles concentrations (from imission);
- Particles concentrations (from emission)..

Fields of interest:

The LaCIEDiN-Laboratory acts according standard SR EN ISO/CEI 17025:2005 and it is RENAR accredited with certificate no. LI 787 from 22.06.2009.

Financed through/by:

S.C. CONFORT SA

Research team:

Prof. Dr. Eng. Ioana Ionel, Assist. Prof. Dr. Eng. Francisc Popescu, Dr. Eng. Nicolae Lontis, Assist. Prof. Dr. Eng. Luisa Dungan, Assist. Dr. Eng. Gavrilă Trif – Tordai

Research centre:

Research Centre for Thermal Machines and Equipments, Transportation and Environmental Pollution Control

Applicability and transferability of the results:

On customer request all results are confidential.

Contact information:

E-mail: ioana.ionel@mec.upt.ro

Web: <http://mettcp.mec.upt.ro/>

Goal of the project:

Determination of gaseous and solid emission pollutants' concentrations from indicated (selected) exhaust sources as well as PM10 imission from the vicinity all concerning the unit area Continental Automotive Products SRL in Timisoara.

Short description of the project:

The product of the research activity for the client is the data report. The quality of this report is given by the quality of the information it contains. For this reason, the precision of the experimental data is an important requirement. The accuracy of the report is based on this precision. The instruments used for measurements are: TESTA FID 123, analyzer 3180 GMH manometer, STROHLEIN STE4, LSV3 analyzer and TESTO 350XL analyzer, all working according EU standardized methods.

Project implemented by:

LaCIEDI^N - Laboratory for Fuel Analyses, Ecological Investigations and Pollutant Dispersion

Main activities:

Measurements in situ/phase, results processing, data interpretation and preparation of the analysis bulletin/report.

Results:

- CO, NO₂, SO (emission) concentrations;
- Particles (emission) concentrations;
- VOC from gaseous effluent indicated as TOC (emission) concentrations;

•PM10 (imission), as air quality indicator in the proximate vicinity.

Fields of interest:

The LaCIEDI^N-Laboratory acts according standard SR EN ISO/CEI 17025:2005 and it is RENAR accredited with certificate no. LI 787 from 22.06.2009.

Implementation period:

January 2012- January 2013

Financed through/by:

SCCONTINENTALAUTOMOTIVEPRODUCTS SRL

Research team:

Prof. Dr. Eng. Ioana Ionel, Assist. Prof. Dr. Eng. Francisc Popescu, Dr. Eng. Nicolae Lontis, Assist. Prof. Dr. Eng. Luisa Dungan, Assist. Dr. Eng. Gavrilă Trif – Tordai

Research centre:

Research Centre for Thermal Machines and Equipments, Transportation and Environmental Pollution Control

Applicability and transferability of the results:

On customer request, the results are confidential.

Contact information:

E-mail: ioana.ionel@mec.upt.ro
 Web: <http://mettcp.mec.upt.ro/>

Goal of the project:

Determination of gaseous and solid pollutants on stacks and air quality (immissions) in the vicinity of the company.

Short description of the project:

The product of the research activity for the client is the analysis report. Thus the quality of this report is resulting from the quality of the information/data basis accomplished through on line measurements. The precision of the experimental data is an important requirement, being thus the basis of the accuracy of the report. The instruments used for measurements are: TESTA FID 123, STROHLEIN STE4, LSV3 analyzer, TESTO 350XL analyzer, analyzer 3180 GMH manometer and mobile laboratory.

Project implemented by:

LaCIEDIIn- Laboratory for Fuel Analyses, Ecological Investigations and Pollutant Dispersion

Implementation period:

July 2012- July 2013

Research centre:

Research Centre for Thermal Machines and Equipments, Transportation and Environmental Pollution Control

Applicability and transferability of the results:

On customer request, the results reports are confidential.

Main activities:

Measurements in situ/phase, results processing, data interpretation and preparation of analysis bulletin/report.

Results:

- VOC from gaseous effluent, indicated as TOC (emission);
- Measurement concentration of the NO, NO₂, NO_x, CO, SO₂ and particles (emission);
- Thermodynamic parameters (pressure);
- Measurement concentration of the CO, NO, NO₂, NO_x, SO₂, CH₄, VOC, TOC, O₃ and PM10 air quality concentrations (immission in the vicinity).

Fields of interest:

The LaCIEDIIn-Laboratory acts according standard SR EN ISO/CEI 17025:2005 and it is RENAR accredited with certificate no. LI 787 from 22.06.2009.

Financed through/by:

SC CONTITECH ROMANIA SRL

Research team:

Prof. Dr. Eng. Ioana Ionel, Assist. Prof. Dr. Eng. Francisc Popescu, Dr. Eng. Nicolae Lontis, Assist. Prof. Dr. Eng. Luisa Dungan, Assist. Dr. Eng. Gavrilă Trif – Tordai

Contact information:

E-mail: ioana.ionel@mec.upt.ro
Web: <http://mettcp.mec.upt.ro/>

Goal of the project:

Determination of gaseous and solid pollutants from the lacquering process of the company.

Short description of the project:

The result of the research activity consists of an attested analysis technical bulletin, accomplished according Romanian legislation necessities. The quality of the report is given by the quality of the information it contains that is recorded in a data base by the instruments and a PC. For this reason, the precision of the experimental data is an important requirement. The accuracy of the report is based on this precision. The instruments used for measurements are: TESTA FID 123 analyzer 3180 GMH micro-manometer and TESTO 350XL analyzer.



TESTO 350XL analyzer

Project implemented by:

LaCIEDiN- Laboratory for Fuel Analyses, Ecological Investigations and Pollutant Dispersion

Implementation period:

December 2011- December 2012

Main activities:

Measurements insitu, database generation, results processing, data interpretation and preparation of the analysis bulletin/report, quality control.

Results:

- CO, NOx, SO₂, O₂, CO₂, HC, concentrations from flue gases;
- VOC from gaseous effluent, indicated as TOC.

Fields of interest:

The LaCIEDiN-Laboratory acts according standard SR EN ISO/CEI 17025:2005 and it is RENAR accredited with certificate no. LI 787 from 22.06.2009.

Financed through/by:

SC ELBA SA, Timisoara

Research team:

Prof. Dr. Eng. Ioana Ionel, Assist. Prof. Dr. Eng. Francisc Popescu, Dr. Eng. Nicolae Lontis, Assist. Prof. Dr. Eng. Luisa Dungan, Assist. Dr. Eng. Gavrilă Trif – Tordai

Research centre:

Research Centre for Thermal Machines and Equipments, Transportation and Environmental Pollution Control

Applicability and transferability of the results:

On customer request, the results reports are confidential.

Contact information:

E-mail: ioana.ionel@mec.upt.ro
Web: <http://mettcp.mec.upt.ro/>

Goal of the project:

Determination of emitted gaseous and solid pollutants' concentration generated by manufacturing processes.

Short description of the project:

The product of the research activity for the client is the analysis report, based on a best practice and measurement procedure, according standardized measuring methods (CEN). The quality of this report is given by the quality of the information it contains. For this reason, the precision of the experimental data is an important requirement and was fully applied. The accuracy of the report is based on the precision of the instrument and on selection of a best location for selecting representative probes. The instruments used for measurements are: TESTA FID 123 analyzer, STROHLEIN STE4 analyzer and TESTO 350XL analyzer.

Project implemented by:

LaCIEDiN- Laboratory for Fuel Analyses, Ecological Investigations and Pollutant Dispersion

Implementation period:

November 2012- November 2013

Fields of interest:

The LaCIEDiN-Laboratory acts according standard SR EN ISO/CEI 17025:2005 and it is RENAR accredited with certificate no. LI 787 from 22.06.2009.

Main activities:

Project steps: measurements in situ / phase, results processing, data interpretation and preparation of analysis bulletin/report.

Results:

- CO, NO_x, SO₂, thermodynamic parameters;
- Particulate;
- VOC from gaseous effluent, indicated as TOC.

Financed through/by:

SC HELLA SA, Timisoara

Research team:

Prof. Dr. Eng. Ioana Ionel, Dr. Eng. Nicolae Lontis, Dr. Eng. Tenchea Adrian, Assist. Prof. Dr. Eng. Luisa Dungan

Research centre:

Research Centre for Thermal Machines and Equipments, Transportation and Environmental Pollution Control

Aplicability and transferability of the results:

For details & references, contact directly our client, the data are confidential.

Contact information:

E-mail: ioana.ionel@mec.upt.ro

Web: <http://mettcp.mec.upt.ro/>

Goal of the project:

Determination in real time of gaseous and solid pollutants emitted from selected points of the unit.

Short description of the project:

The product of the research activity for the client is the analysis report. The quality of this report is given by the quality of the information it contains. For this reason, the precision of the experimental data is an important requirement. The accuracy of the report is based on this precision. The instruments used for measurements are: TESTA FID 123, STROHLEIN STE4 analyzer, TESTO 350XL analyzer and 3180 GMH manometer analyzer. All are quality controlled by the national standard institutions.

Project implemented by:

LaCIEDiN - Laboratory for Fuel Analyses, Ecological Investigations and Pollutant Dispersion

Implementation period:

May 2012- May 2013

Aplicability and transferability of the results:

On customer request the analysis reports are confidential.

Financed through/by:

S.C. HONEYWELL LIFE SAFETY ROMANIA SRL

Main activities:

Measurements in situ, results processing, data interpretation and preparation of analysis bulletin/report, quality control.

Results:

- Particles concentrations;
- CO, NOx and SO₂, CO₂ and O₂ concentrations;
- VOC from gaseous effluent, indicated as TOC (from emission), concentrations.

Fields of interest:

The LaCIEDiN- Laboratory acts according standard SR EN ISO/CEI 17025:2005 and it is RENAR accredited with certificate no. LI 787 from 22.06.2009.

Research team:

Prof. Dr. Eng. Ioana Ionel
Assist. Prof. Dr. Eng. Francisc Popescu
Dr. Eng. Nicolae Lontis
Assist. Dr. Eng. Gavrilă Trif – Tordai

Research centre:

Research Centre for Thermal Machines and Equipments, Transportation and Environmental Pollution Control

Contact information:

E-mail: ioana.ionel@mec.upt.ro
Web: <http://mettcp.mec.upt.ro/>

Goal of the project:

Determination of gaseous and solid pollutants from measuring the emission and immission.

Short description of the project:

The result of the contract for the client is the analysis report. The quality of this report is based on the quality of the information that is monitored. For this reason, the precision of the experimental data and instruments involved is an important requirement. The accuracy of the report is based on this precision. The instruments used for measurements are: TESTA FID 123 analyzer, STROHLEIN STE4 analyzer and TESTO 350XL analyzer (emission) and mobile laboratory (air quality).



Mobile laboratory

Project implemented by:

LaCIEDiN - Laboratory for Fuel Analyses, Ecological Investigations and Pollutant Dispersion

Implementation period:

November 2012- November 2014

Main activities:

Project steps: planning of the campaigns,

measurements in situ, result processing, data interpretation and preparation of analysis bulletin/report.

Results:

- CO, CO2, O2, NO, NO2, NOx, SO2, CH4 (from emissions);
- Particulate (emission);
- NO, NO2, NOx, SO2 CO, PM10, O3, CH4, VOC, TOC and meteorological parameters (air quality).

Fields of interest:

The LaCIEDiN- Laboratory acts according standard SR EN ISO/CEI 17025:2005 and it is RENAR accredited with certificate no. LI 787 from 22.06.2009.

Financed through/by:

SC SMITHFIELD PROD SRL

Research team:

Prof. Dr. Eng. Ioana Ionel,
Dr. Eng. Nicolae Lontis,
Dr. Eng. Tenchea Adrian

Research centre:

Research Centre for Thermal Machines and Equipments, Transportation and Environmental Pollution Control

Aplicability and transferability of the results:

On customer request, the results are confidential, thus at request the client directly can offer them.

Contact information:

E-mail: ioana.ionel@mec.upt.ro
Web: <http://mettcp.mec.upt.ro/>

Goal of the project:

Determination of gaseous and solid pollutants from indicated working point inside and outside the unit.

Short description of the project:

The product of the research activity for the client is the analysis report. The quality of the report is connected to the quality of the information it contains. For this reason, the precision of detecting the experimental data is an important requirement. The accuracy of the report is based on this precision. The instruments used for measurements are: TESTA FID 123, TESTO 350XL analyzer and LSV3 analyzer, all being metrological controlled and working according EU methods.

Project implemented by:

LaCIEDIⁿ - Laboratory for Fuel Analyses, Ecological Investigations and Pollutant Dispersion

Main activities:

Project steps: organizing of the relevant measuring sites, measurements in situ, results processing, data interpretation and preparation of analysis bulletin, quality control.

Financed through/by:

S.C. TMD FRICTION ROMANIA SRL

Results:

- PM10 concentrations (environmental air);
- CO, CO₂, NO, NO₂, NO_x and SO₂ concentrations (from emission);

- VOC from gaseous effluent, indicated as TOC (from emission).

Fields of interest:

The LaCIEDIⁿ- Laboratory acts according standard SR EN ISO/CEI 17025:2005 and it is RENAR accredited with certificate no. LI 787 from 22.06.2009.

Research team:

Prof. Dr. Eng. Ioana Ionel, Assist. Prof. Dr. Eng. Francisc Popescu, Dr. Eng. Nicolae Lontis, Assist. Dr. Eng. Gavrilă Trif – Tordai

Research centre:

Research Centre for Thermal Machines and Equipments, Transportation and Environmental Pollution Control

Aplicability and transferability of the results:

On customer request, the analysis reports are confidential. Questions and information should be addressed directly to the customer.

Implementation period:

May 2012- December 2012

Contact information:

E-mail: ioana.ionel@mec.upt.ro

Web: <http://mettcp.mec.upt.ro/>

Goal of the project:

Determination of gaseous and solid pollutants exhausted from selected working point.

Short description of the project:

The product of the research activity for the client is the analysis report. The quality of this report is given by the quality of the information it contains. For this reason, the precision of the experimental data is an important requirement. The accuracy of the report is based on this precision. The instruments used for measurements are: TESTA FID 123, STROHLEIN STE4 analyzer and TESTO 350XL analyzer.

Project implemented by:

LaCIEDIIN - Laboratory for Fuel Analyses, Ecological Investigations and Pollutant Dispersion

Implementation period:

April 2012- December 2012

Main activities:

Measurements in situ, results processing, data interpretation and preparation of analysis bulletin/report, quality check.

Fields of interest:

The LaCIEDIIN- Laboratory acts according standard SR EN ISO/CEI 17025:2005 and it is RENAR accredited with certificate no. LI 787 from 22.06.2009.

Results:

- Particulate concentrations;
- CO, NOx and SO₂ concentrations;
- VOC from gaseous effluent, indicated as TOC (from emission), concentrations.

Financed through/by:

S.C. TRW AUTOMOTIVE SAFETY SYSTEMS SRL

Research team:

Prof. Dr. Eng. Ioana Ionel, Assist. Prof. Dr. Eng. Francisc Popescu, Dr. Eng. Nicolae Lontis, Assist. Prof. Dr. Eng. Luisa Dungan, Assist. Dr. Eng. Gavrilă Trif – Tordai

Research centre:

Research Centre for Thermal Machines and Equipments, Transportation and Environmental Pollution Control

Applicability and transferability of the results:

On customer request, the data reports are confidential and might be offered only directly.

Contact information:

E-mail: ioana.ionel@mec.upt.ro

Web: <http://mettcp.mec.upt.ro/>



Goal of the project:

Determination of gaseous and solid pollutants from working point.

Short description of the project:

The product of the research activity for the customer is given by the analysis report and further the quality of this report is given by the quality of the information it contains. For this reason, the precision of the experimental data is an important requirement and is checked with appropriate standardized and legal advice. The accuracy of the report is based on the precision of the process instruments and data selection, not mentioning the working place organization. The instruments used for measurements are: TESTA FID 123 (emission), and Analyzer LSV3 and mobile laboratory (air quality).

Project implemented by:

LaCIEDIⁿ - Laboratory for Fuel Analyses, Ecological Investigations and Pollutant Dispersion

Implementation period:

April 2012- December 2012

Research centre:

Research Centre for Thermal Machines and Equipments, Transportation and Environmental Pollution Control

Main activities:

Organization management, quality control, measurements in situ, results processing, data interpretation and preparation of analysis bulletin/report.

Results:

- CO, NO, NO₂, NO_x, SO₂, CH₄, VOC, TOC, O₃ and PM10 concentrations (air quality).
- VOC from gaseous effluent, indicated as TOC (from emission).

Fields of interest:

The LaCIEDIⁿ-Laboratory acts according standard SR EN ISO/CEI 17025:2005 and it is RENAR accredited with certificate no. LI 787-22.06.2009.

Financed through/by:

S.C. TRW AUTOMOTIVE SAFETY SYSTEMS SRL

Research team:

Prof. Dr. Eng. Ioana Ionel, Assist. Prof. Dr. Eng. Francisc Popescu, Dr. Eng. Nicolae Lontis, Assist. Prof. Dr. Eng. Luisa Dungan, Assist. Dr. Eng. Gavrilă Trif – Tordai

Applicability and transferability of the results:

On customer request, the results are confidential.

Contact information:

E-mail: ioana.ionel@mec.upt.ro

Web: <http://mettcp.mec.upt.ro/>

Goal of the project:

Determination of concentration of Volatile Organic (VOC), expressed Total Organic Carbon (TOC) from manufacturing processes.

Short description of the project:

The product of the research activity for the client is the analysis report. The quality of this report is given by the quality of the information it contains. For this reason, the precision of the experimental data is an important requirement. The accuracy of the report is based on this precision. The instrument used for measurements is TESTA FID 123 analyzer.

Project implemented by:

LaCIEDiN - Laboratory for Fuel Analyses, Ecological Investigations and Pollutant Dispersion

Implementation period:

August 2012- December 2012

Financed through/by:

SC ZOPPAS INDUSTRIES ROMANIA SRL

Aplicability and transferability of the results:

On customer request, the analysis reports are confidential.

Main activities:

Project steps: measurements in situ, results processing, data interpretation and preparation of analysis bulletin/report, quality check, management of resources.

Results:

•VOC from gaseous effluent concentrations, indicated as TOC.

Fields of interest:

The LaCIEDiN-Laboratory acts according standard SR EN ISO/CEI 17025:2005 and it is RENAR accredited with certificate no. LI 787 from 22.06.2009.

Research team:

Prof. Dr. Eng. Ioana Ionel, Assist. Prof. Dr. Eng. Luisa Dungan, Dr. Eng. Nicolae Lontis, Dr. Eng. Tenchea Adrian

Research centre:

Research Centre for Thermal Machines and Equipments, Transportation and Environmental Pollution Control

Contact information:

E-mail: ioana.ionel@mec.upt.ro

Web: <http://mettcp.mec.upt.ro/>

Goal of the project:

Identification, evaluation and monitoring of air pollutants, NO, NO₂, NO_x, CO, CO₂, O₂, NH₃, VOC, Zn, particles and thermodynamic parameters from several sources at Berg Banat Fagaras zinc plating plant.

Short description of the project:

The project consists in quarterly measurements of air pollutants resulted from the zinc plating main activity of the BERG BANAT Fagaras branch plant. Thru these measurements the plant operator tunes its equipments both for productivity and quality of its products and environmental protection.



Project implemented by:

Faculty of Mechanical Engineering, Department of Mechanical Machines, Equipment and Transportation

Implementation period:

February 2012 – December 2013

Main activities:

Quarterly measurements episodes for air pollutants NO, NO₂, NO_x, CO, CO₂, O₂, NH₃, VOC, Zn, particles. Thermodynamics parameters of flue gases and residuals are also monitored to optimize the zinc plating procedures.

Results:

An extensive database for main air pollutants for large zinc plating plants.

Fields of interest:

Zinc Plating emissions, Thermodynamics, Environmental engineering, Environmental protection, Combustion.

Financed through/by:

BERG BANAT, Fagaras brach

Research team:

Francisc Popescu, Ioana Ionel, Nicolae Lontis, Gavrilă Trif-Tordai, Luisa Dungan

Research centre:

Research Centre for Thermal Machines and Equipments, Transportation and Environmental Pollution Control

Aplicability and transferability of the results:

Through this research typical air pollutant concentrations were identified and measured, and the results are applicable to any large zinc plating facility.

Contact information:

E-mail: francisc.popescu@mec.upt.ro

Web: <http://mmut.mec.upt.ro/>

Goal of the project:

It is developed a new methodology for two-dimensional axi-symmetric swirling flow computation downstream the Francis runners in order to optimize the draft tube performances within an operating range.

Short description of the project:

The investigation in the current project is focused on developing a computer code for evaluating the swirling flow downstream the Francis runners. Such that we accommodate an inlet section as close as possible to the blade trailing edge, while extending the computational domain in the discharge cone.

Project implemented by:

ALSTOM HYDRO FRANCE and „Politehnica” University of Timisoara – National Centre for Engineering of Systems with Complex Fluids and Hydraulic Machinery Department

Implementation period:

September 2012- March 2013

Main activities:

Analysis of the 2D swirling flow downstream a Francis runner within the discharge cone.

Development of a 2D swirling flow code and code validation within a large operating range.

Results:

Susan-Resiga R.F., Muntean S., Ciocan T., Joubarne E., Leroy P., Bornard L., *Influence of the velocity field at the inlet of a Francis turbine draft tube on performance over an operating range*, IoP Conf. Series: Earth and Environ. Science, 15.03.2008.
(<http://iopscience.iop.org/1755-3/032008>)

Fields of interest:

Optimization in Hydro Turbines

Financed through/by:

ALSTOM HYDRO FRANCE

Research team:

Prof. Dr. Eng. Susan-Resiga Romeo, Dr. Eng. Muntean Sebastian - CS I, Dr. Eng. Anton Alin Adrian, Eng. Ciocan Tiberiu PhD student, Eng. Ighișan Cosmin PhD student

Research centre:

Research Centre for Complex Fluid Systems Engineering

Aplicability and transferability of the results:

The new methodology will be applied in the early design stage of the Francis runners in order to extend the operating range as well as to improve the energy behaviour.

Contact information:

E-mail: resiga@mh.mec.upt.ro



Goal of the project:

Through this paper the premises to advance a report to state institutions for including the TIA in the investment programme for the following timespan were created, which has already been materialized.

Short description of the project:

The project involved analysing and improving the development plan of the "Traian Vuia" Timișoara International Airport SA starting out from the new social, economic and political conditions existent in the year 2012.

Project implemented by:

Prof. Eng. dr. ec. Mocan Marian – Project Manager and the team members who were: Conf. dr. Eng. Pugna Adrian, Conf. dr. arh. Radoslav Radu, Drd. Eng. Maistor Sorin.

Implementation period:

May 2012– September 2012

Main activities:

Current activity analysis, interviews with the main decision factors from within the TIA, analysis of the socioeconomic status in Romania and the European Union, elaborating scenarios and forecasted budgets, calculation of indicators.

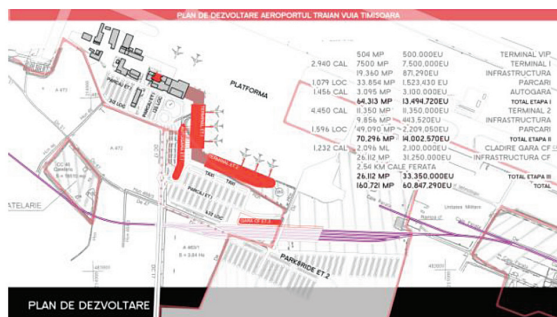

Results: Traffic results and general financial results of the TIA are good so far, air-station

spaces for passengers (public areas and terminals), parking and cargo facilities tend to become insufficient from the point of view of the usable space that it offers for the fluent processing of passenger and luggage flows, Platforms for airship stationing are crowded and, consequently, the number of stationing positions tends to become insufficient for a safe and fluent handling of this activity, the runway needs modernising, A concrete integration of TIA activities with those of nearby logistics centres does not exist, an entry in TIA shareholdership of the County Councils from the West region for an easier access to funds is being proposed.

Fields of interest:

Economics, entrepreneurship, leadership, logistics

Financed through/by:

"Traian Vuia" Timișoara International Airport

Research team:

Prof. Dr. Eng. Ec. Mocan Marian, Assoc. Prof. Dr. Eng. Pugna Adrian, Assoc. Prof. Dr. Arh. Radoslav Radu, Eng. Maistor Sorin PhD student, Dr. Eng. Bătea Alin, Ec. Duran Irina Daniela PhD student, Eng. Mircea Negrut PhD student, Student Danciu Mihai, Dr. mat. Pater Liliana

Research centre:

Research Centre for Engineering and Management.

Aplicability and transferability of the results:

The study can also be applied to other similar economical entities from Romania.

Contact information:

Email: marian.mocan@mpt.upt.ro

Goal of the project:

This project has as main goal to increase the visibility of the Guban brand in Romania.

Short description of the project:

A three year research undertaken regarding the consumer behavior has shown that brand equity can be reached through “prosumer” creative engagement. The innovative approach of the “prosumer” concept was defined by the research team as an active consumer who becomes a participant in corporate activities, providing value to the company in an open innovation approach. Therefore this project has presented four prosumer oriented marketing strategies for value co-creation and visibility in the market. From those four only the ones that perfectly fit the Romania marketplace have been selected for implementation by the project’s recipient.

Main activities:

After a complex SWOT analysis, a quantitative market study, and a competitive analysis, two of the four prosumer oriented strategies have been selected for implementation: a product customization service (Company + nCompany for Client) and a crowdsourcing campaign (Company + nProsumer) developed through several creative contests which will involve the brand consumers (prosumers). The two strategies are designed using Design for Six Sigma methodology.

Results:

The consumer requirements for the two services have been established through Kano questionnaires. We are now developing test pilots for a step by step implementation.

Fields of interest:

Marketing, Strategic Management, Consumer behavior, Innovation

Financed through/by:

S.C. GP& COMPANY SA

Research team:

Prof. Dr. Eng. Monica Izvercianu
PhD Student Sabina Alina Șeran

Research centre:

Research Centre for Engineering and Management

Aplicability and transferability of the results:

The results are implemented by S.C. GP&COMPANY SA in their intent to increase the visibility of the Guban brand in Romania. The dissemination of results will be made in high quality publications.

Contact information:

E- mail: seran.sabina@yahoo.com

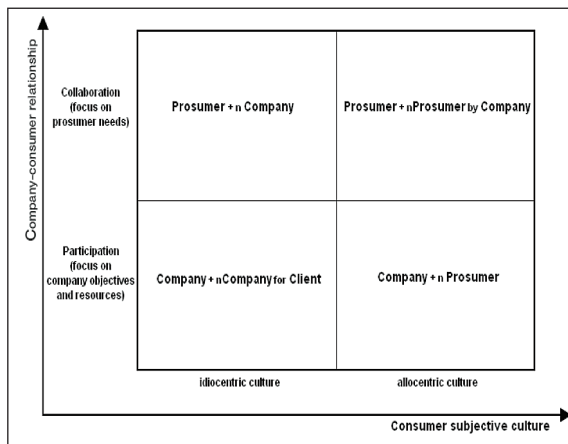

Project implemented by:

Politehnica University of Timisoara

Implementation period:

December 2012– June 2013

Patents granted in 2012 – holder UPT**1. Amorphous alloy magnetic screening product and the procedure for obtaining it**

Inventors: Șerban V. A., Codrean C., Buzdugan D., Uțu I. D.

Patent no. 126021/2012

2. Flat cam steering mechanism

Inventors: Cipleu A., Draghici A., Ciodaru G., Lovasz E. C.

Patent no. 123472/2012

3. Inductor for joining by brazing, soldering or welding of steel tubes and profiles

Inventors: Nicoară M., Răduță A., Șerban V.

Patent no. 125284/2012

4. Hot channel mold

Inventors: Iclănzan T., Stan D., Tulcan A., Seiculescu V., Cosma C.

Patent no. 123400/2012

5. Construction of biogas from biodegradable municipal waste

Inventors: Savu Al., Ionel I., Fluturaș M., Savu B., Popescu F., Loniș N., Cioabla A., Matei A., Barboni V.

Patent no. 125718/2012

Patent applications in 2012 – holder UPT**1. Tracking method of fingers and means of human-computer communication**

Inventors: Gui V., Alexa F., Căleanu C., Popa Gh., David C., Simion G.

Application no. A /00126/27.02.2012

2. Rotators with ultrasonic activation for machining, abrasives and ultrasonic erosion

Inventors: Turc C., Stan D., Tulcan A., Oanca O.

Application no. A /00780/01.11.2012

3. Thermomagnetic control actuator

Inventors: Crăciunescu C., Budău V., Mitelea I.

Application no. A/00861/23.11.2012

4. Bilayer Actuator

Inventors: Crăciunescu C., Budău V., Mitelea I.

Application no. A/00862/23.11.2012

5. Process for rapid electrochemical detection of arsenic in aqueous solutions

Inventors: Manea F., Pop A., Remeș A., Baci A.

Application no. A/00555/25.07.2012

6. Procedures for obtaining and reconditioning quartz crucibles for developing amorphous metal alloys

Inventors: Șerban V., Codrean C., Buzdugan D., Cornea F., Laza I.

Application no. A/00885/26.11.2012

7. Multicava cylindrical lighter produced from pulverulent and shredded ferrous waste with granulation under 2 mm

Inventors: Heput T., Crișan E., Ardelean E., Socalici A., Ardelean M.

Application no. A/00130/28.02.2012

Patent applications in 2012 - holder other than UPT, inventors of UPT

1. Method and system to detect 3D compatible frames

Inventors: Micea M.

Application no. A/00376/29.05.2012

Patent holder : S.C. MOVIDIUS SRL, Timișoara

2. Solar irrigation system

Inventors: Nanu S., Șumălan R.

Application no. A/00954/05.12.2012

Patent holder: Cluster ROSENC

3. Wind turbine with vertical axis

Inventors: Ciurdar O., Ciupe V.

Application no. MU00071/12.12.2012

Patent holders: Ciurdar Ovidiu, Ciupe Valentin

**Doctor Honoris Causa
Prof. Branislav TODOROVIC – Belgrade University**

Scientific personality widely recognized in the HVAC (Heating Ventilation and Air Conditioning) field, Professor at Belgrade University and at South-East University in Nanjing (permanent visiting professor), editor of the Energy and Buildings Journal published by Elsevier and of Serbian HVAC, and member of other several professional and international associations. He received prizes and medals awarded by the Yugoslav Government, Belgrade City Hall, Fulbright Association, ASHRAE, HERVA, and AHR Timisoara. Professor Branislav Todorovic was conferred the title of *Doctor Honoris Causa* by "Politehnica" University of Timisoara on the 22nd of November 2012.



**Honorary Professor
Dr. Christian von ALBRICHSFELD
General Manager Continental Automotive România**

Dr. Christian von Albrichsfeld played a special role in the relation university – industry, this collaboration having an important scientific component, reflected in designing research, and an institutional one, as well, mirrored in the improvement of the academic education and its adaptation to the European standards. Dr. Christian von Albrichsfeld has been offering "Politehnica" University of Timisoara continuous support for the organization of various events. Dr. Christian von Albrichsfeld was awarded the title of *Honorary Professor* by "Politehnica" University of Timisoara on the 13th of September 2012.



Shape Memory Alloys Engineered from the Macro to the Nano Realm
Author: Corneliu – Marius CRĂCIUNESCU

Abstract: The Habilitation Thesis “Shape Memory Alloys Engineered from the Macro to the Nano Realm” reflects the activity of the author, performed between 1997 and 2012, on the development of shape memory alloys. It is based on original contributions performed during research activities financed by “Politehnica” University of Timisoara, University of Maryland at College Park, Centre for European Studies and Research Bonn and Universidade Nova de Lisboa.

The first part of the thesis details the oriented research focused on the identification of new shape memory alloy systems, on the transfer of properties at micro and nanoscale and the development of investigation tools for cost-efficient exploration of new functional and multifunctional alloy systems in compositional spreads. Co-Ni-Ga is the main system discussed, based on experimental observations, belonging to the ferromagnetic shape memory alloys group.

The second part highlights the original contribution to the structural control of shape memory alloys within the micro and nanocrystalline range and the resulting influence on particular functionalities, by means of severe plastic deformation, rapid solidification of bulk or ribbons and films deposited by sputtering and laser ablation, respectively microengineered transitions in shape memory alloys films are the subject of the third part focused on the ways to control the phase transformations that develops under thermoelastic constraints, in order to tune the actuation of bimorph and trimorph-type actuators.

The challenges in shape memory alloy welding have been addressed by identifying methods that could lead to



minimal changes in the composition, microstructure and functionality, as well as on the interaction between laser beam and new shape memory alloys belonging to the ferromagnetic group.

The plan for advancement and career development is based on the proven skills to conduct and coordinate high-level research and teaching activities at academic level and to initiate successful international collaborations in the field of advanced materials. The plan is structured on several interrelated activities - design, fabrication, implementation, education and training in the field of advanced materials - that fully complement each other in the same directions, and aims to:

The full abstract at: <http://www.cnatdcu.ro/wp-content/uploads/2012/06/Rezumatul-Tezei-de-abilitare.pdf>

Habilitation Commission:

Prof. Gunther EGGELER,
Ruhr University of Bochum, Germany;
Prof. Leandru BUJOREANU
“Gh. Asachi” Technical University of Iași,
România;
Prof. Traian PETRIȘOR
Technical University of Cluj-Napoca,
România.

Abstract: In a society characterized by frequent changes, software must evolve at the same pace. To be able to evolve and adapt to new requirements, software has to be prepared for changes, which in return require high design and implementation quality. This habilitation thesis is the summary of the research that we performed during the last ten years on the assessment and improvement of design quality in object-oriented systems. This research direction has grown significantly over the last years due to the exponential increase of large-scale object-oriented systems. In such systems integration or bug fixing become so unpredictable that it becomes more cost-effective to rewrite the system.

However, the cause of such situations is less visible: the internal quality of the system's design is declining; and duplicated code, overly complex methods or non-cohesive classes are just a few signs of this decline. These, and many others, are usually the symptoms of higher-level design problems, which are usually known as design flaws. In software engineering, measurement is essential, as otherwise we risk losing control due to excessive complexity. Consequently, software metrics are the foundation of our research.

Thus, we start the thesis by describing our approach to defining metrics in a way that is both accurate and easy to understand, and to establishing meaning full metrics thresholds. In the context of metrics we also introduce the Overview Pyramid, an integrated, metrics-based visualization aimed to characterize the complexity, coupling and inheritance usage in object-oriented system.

While metrics are needed for the assessment of software design, we argue that isolated metrics cannot serve this goal in a way that leads to improvement actions. Going from abnormal numbers to the recognition of design flaws is impossible because the interpretation of individual metrics is too fine grained to indicate real design flaws.



The full abstract at:

<http://www.cnatdclu.ro/wp-content/uploads/2012/06/Teza-de-abilitare3.pdf>

Habilitation Commission:

Prof. Sergiu NEDEVSCI

Technical University of Cluj-Napoca,
România;

Prof. Bazil PARV

Babeş Bolyai University, Cluj-Napoca,
România;

Prof. Adrian MARCUS

Wayne State University, Detroit, USA.

Abstract: The research activity and achievements presented here are developed in two main thematic directions. The first one is “Thin-walled cold-formed steel members”, which continues and diversify with new subjects, the topic of the PhD Thesis. It should be noted that the activity of the candidate in the field of thin-walled cold-formed steel structures (18 years of research in this field), from the beginning, from November 1994, until the defending of PhD Thesis, and for the post-thesis period, is in line with the fields of research of Steel Structures Research School of Timișoara. It may be underlined the long tradition of the Timișoara School in the field of thin-walled cold-formed steel structures – more than 40 years of activity. The new subjects of research in the post-thesis period can be divided in two big classes, each of them related to the following aspects:

Theoretical contributions:

- Post-elastic strength of thin-walled cold-formed steel members. Plastic mechanisms for members in compression and bending;
- Behavior of multi-span cold-formed Z-purlins with bolted lapped connections;
- Ultimate design capacity of pitch-roof portal frames made by thin-walled cold-formed steel members;
- Behavior of cold-formed steel perforated pallet rack sections in compression.

Innovative structural systems:

- Wall Stud Modular System (WSMS) – Bungalow type buildings used as shops, offices, for industrial purposes, for housing or school facilities;
- Hall Type Framed Structure (HTFS) – are

used as small and medium size single storey industrial buildings and storehouses;

- Penthouse Framed Structure (PFS) – for refurbishment and restructuring by vertical addition of new storey the existing buildings;
- Affordable Houses (AH).

For these innovative structural systems both technical and environmental performances have been studied.

The main achievements and results are presented in detail in Chapter (b-i): Scientific, professional and academic achievements.



The full abstract at:

<http://www.cnatdclu.ro/wp-content/uploads/2012/06/Teza-de-abilitare3.pdf>

Habilitation Commission:

Prof. Raffaele LANDOLFO
University Federico II of Napoli, Italy;

Prof. Dinar CAMOTIM
University of Lisabona, Portugal;

Prof. Cosmin CHIOREAN
Technical University of Cluj-Napoca,
România.

Abstract: Since the PhD thesis elaborated in 1997 the professional activities in the field of research and education had the topics related to thermal engineering. Until 2002 the topics were mostly in the field of compact heat exchangers and numerical modeling of thermal phenomena. In 2002 research activities were performed at the University Of Tokyo Institute Of Industrial Science through the project made in Prof. Shigefumi Nishio laboratory with the following title: Study of Micro-channel Heat Sinks for LSI Chip Cooling. Considering, at that time the available results about experimental research on micro-channel heat transfer and fluid flow characteristics, one can conclude that there were a large scattering in the obtained results. This was especially serious in the case of the heat transfer results. For example, there is an optimum size of channels in the so-called micro-channel heat sink and the result of optimization depends strongly on the heat transfer characteristics in micro-channels. So, this was the reason for making the experimental research on single-phase micro tube heat transfer. The research report was published in the International Journal of Heat and Mass Transfer [24] that was cited 93 times since 2005. After that, the research activities in the field of micro-channel heat transfer and fluid flow were further developed at the *Politehnica* University of Timisoara and Laboratory for numerical simulations in thermal engineering. The issues that were considered were related to influence of fluid properties, wall axial conduction, partial heating and viscous heating on heat transfer and fluid flow behavior in micro-channels. It has to be state that for these phenomena the proper numerical

codes were developed based on finite volume method considering microtubes and micro-channel heat sinks.

Moreover, in order to optimize the micro scale thermal devices the various flow configurations were considered. The new concept of micro-channel heat sink with tangential impingement jet at the inlet cross section was proposed.



The full abstract at:

http://www.cnatdcu.ro/wp-content/uploads/2012/06/teza_abilitare_Lelea.pdf

Habilitation Commission:

Prof. Veturia CHIROIU
Institute of Solid Mechanics of the
Romanian Academy;

Prof. Corneliu BĂLAN
Politehnica University of București,
România;

Prof. Mihai ARGHIR
University of Poitiers, France.

Computers and Information Technology

Mihaela-Marcella VIDA

Supervisor prof. L. Stoicu-Tivadar

Contribuții asupra interoperabilității sistemelor informatice medicale aplicate în sisteme de evidență electronică a stării de sănătate a pacientului

(Contributions on Medical Information Systems Interoperability Demonstrated at Electronic Healthcare Records Systems)

Gabriel GÎRBAN

Supervisor prof. M. Popa

Monitorizarea sarcinii disponibile în nodurile rețelelor de senzori fără fir prin determinarea consumului de energie cu metode online și offline

(State of Charge Monitoring in WSN Nodes Using Online and Offline Methods to Obtain the Energy Consumption)

Liviu AGNOLA

Supervisor prof. M. Vlăduțiu

Self Adaptive Cache Memories

Patrik-Emanuel MEZO

Supervisor prof. M. Vlăduțiu

Distributed Mailing System

Septimiu-Fabian MARE

Supervisor prof. M. Vlăduțiu

Advanced Steganographic Algorithms and Architectures

Andrei LIHU

Supervisor prof. S. Holban

Diferendul - un nou concept social în inteligență colectivă și calculul evoluționist

(Disagreements - a New Social Concept in Swarm Intelligence and Evolutionary Computation)

Norbert GAL

Supervisor prof. V. Stoicu-Tivadar

Contribuții la utilizarea tehnicilor fuzzy în analiza imaginilor medicale

(Contributions to Fuzzy Techniques in Medical Image Analysis)

Claudiu-Raul ROBU

Supervisor prof. V. Stoicu-Tivadar

Contribuții la îmbunătățirea tehnologiei de clasificare a datelor

(Contributions to Improving Data Classification Technology)

Valentin-Sergiu GOMOI

Supervisor prof. V. Stoicu-Tivadar

Interoperability of Heterogeneous Sources of Patient

Clinical Data and Sources of Patients Clinical Practice Guidelines Formalisms to Leverage Computerized Decision Support

Mihai FĂGĂDAR-COSMA

Supervisor prof. V. Crețu

Foreground Extraction in Video Conferences Using Motion Flow Analysis

Systems Engineering

Alina-Mădălina LONEA
Supervisor prof. O. Proștean
Supervisor prof. H. Tianfild
Security Solutions for Cloud Computing

Cosmin KOCH-CIOBOTARU
Supervisor prof. O. Proștean
Voltage Control and Optimization of Energy Consumption in a Microgrid

Flavius-Maxim PETCUȚ
Supervisor prof. T. L. Dragomir
Supervisor prof. R. Băncilă
Modele matematice pentru dispozitive fotovoltaice și utilizarea lor în sisteme de conducere automată
(Mathematical Models for Photovoltaic Devices and Their Use in Automatic Control)

Mihai IACOB
Supervisor prof. G.D. Andreescu
Control Solutions with Hardware in the Loop and SCADA System for Drum Boiler Turbine Process in Thermal Power Plants

Electrical Engineering

Iulia CĂȚA
Supervisor prof. D. Toader
Analiza influenței parametrilor liniilor electrice aeriene asupra regimurilor tranzitorii provocate de avarii în subsistemele electroenergetice
(The Influence of the Parameters of the Overhead Lines on the Transient Caused by Faults)

Beatrice ARVINTI
Supervisor prof. D. Toader
Contribuții la monitorizarea de la distanță a activității electrice a inimii
(Contributions to Remote Monitoring of the Electrical Activity of the Heart)

Ion-Petru RUȘEȚ
Supervisor prof. C. Șora
Optimizarea regimului de funcționare a rețelelor de medie tensiune având neutrul tratat cu bobina de compensare
(Optimization of Operation G Mode of the Medium Voltage Power Networks with Resonant Earthed Neutral)

Daniela-Claudia VESA
Supervisor prof. C. Șora
Cercetări privind forțele exercitate de câmpul magnetic macroscopic asupra lichidelor magnetice
(Researches About the Forces Exerted by the Macroscopic Magnetic Field on Magnetic Liquids)

Ana Adela MOLDOVAN
Supervisor prof. I. Boldea
Active Flux Based V/F with Stabilizing Loops Versus Vector Control of IPMSM

Anamaria UNGUREAN
Supervisor prof. I. Boldeanu
An Automotive Air Conditioning Compressor Electric Motor Drive

Vlad-Nicolae GRĂDINARU
Supervisor prof. I. Boldea
High Speed Brushless DC PMSM Drives: Optimal Design and Control Contributions

Electronics and Telecommunication Engineering

Cristina-Laura STOLOJESCU
Supervisor prof. A. Isar
Supervisor prof. P. Lenca
A Wavelets Based Approach for Time Series Mining

Teodor PETRIȚA
Supervisor prof. A. Ignea
Contribuții la modelarea unor caracteristici ale antenelor
(Contributions to the Modelling of Some Characteristics of Antennas)

Adrian MIHĂIUȚI
Supervisor prof. A. Ignea
Contribuții la Modelarea Propagării Undelor-Radi
(Contributions to Radio Wave Propagation Modelling)

Liliana STOICA
Supervisor prof. A. Ignea
Contribuții la prelucrarea numerică a semnalelor cu funcții spline
(Contributions to Digital Signal Processing with Spline Functions)

Cora IFTODE
Supervisor prof. A. Ignea
Contribuții la dozimetria de radiofrecvență în expunerile controlate ale probelor biologice
(Contributions to Radiofrequency Dosimetry in Controlled Biological Exposures)

Silvana-Oana POPESCU
Supervisor prof. A. Gontean
Contributions To FPGA-Based Digital
(Modulation/Demodulation Techniques)

Ruxandra-Ioana RUSNAC
Supervisor prof. A. Gontean
Contributions to Target Detection in Wireless Sensor Networks

Tatiana HODOROGEA
Supervisor prof. C. I. Toma
Modern Technologies Used for Secure Data Communications

Romulus REIZ
Supervisor prof. I. Naforniță
Contribuții la estimarea frecvenței instantanee utilizând reprezentări timp-frecvență
(Contributions to Instantaneous Frequency Estimation Using Time- Frequency Representations)

Ion-Cosmin DIȚĂ
Supervisor prof. M. Oteșteanu
Optimizarea recunoașterii codurilor data matrix în mediul industrial
(Optimization of Recognition of the Industrial Data Matrix Codes)

Vasile-Horia MUNTEAN
Supervisor prof. M. Oteșteanu
Dynamic Adaptation Algorithm for Multimedia Delivery in Wireless Networks

Wolfgang PROSS
Supervisor prof. M. Oteșteanu
Supervisor prof. F. Quint
Design of Robust 2D Barcodes for Industrial Environments

Sorin POPA
Supervisor prof. M. Naforniță
Contribuții la implementarea și optimizarea rețelelor de comunicații mobile celulare
(Contributions to the Implementation and Optimization of Mobile Cellular Networks)

Marin MANGRI
Supervisor prof. M. Naforniță
Tracing Optimization of Real Time Protocols in IMS IP-Multimedia Subsystems

Bogdan DRĂGULESCU
Supervisor prof. R. Vasiu
Tehnologiile web-ului semantic în mediul educațional
(Semantic Web Technologies in Educational Context)

Petru PAPAȘIAN
Supervisor prof. T. Mureșan
Optimizarea conducerii proceselor tehnologice prin utilizarea de subsisteme inteligente
(Technological Process Control Optimization Using Intelligent Subsystems)

Florin PRUTIANU
Supervisor prof. V. Popescu
Contribuții privind structurile de testare automată cu aplicații în automotive
(Contributions Brought to Automated Testing Systems With Applicability in Automotive)

Mihai-Emanuel BASCH
Supervisor prof. V. Tîponuț
Bio-Inspired Obstacle Detection System

Chemistry

Paulina VLĂZAN
Supervisor prof. M. Ștefănescu
Ferite de cobalt nanocristaline, obținute prin metode alternative. Structura, proprietăți și aplicații potențiale
(Nanocrystalline Cobalt Ferrite Obtained by Alternative Methods Structure. Properties and Potential Applications)

Mirela-Ionela BARBU
Supervisor prof. M. Ștefănescu
Noi metode de Sinteză a Nanomaterialelor pe Bază de $MnCr_2O_4$
(New Methods for the Synthesis of $MnCr_2O_4$ Nanomaterials)

Adina-Elena AVACOVICI
Supervisor prof. Z. Gârban
Investigarea metaboliților purinici și ionilor metalici specifici în biogeneza uroconcrementelor litiazice
(Investigation of Specific Purinic Metabolites and Metal Ions in the Biogenesis of Lithiasic Uroconcrements)

Chemical Engineering

Marilena FAIER-CRIVINEANU

Supervisor prof. D. M. Perju

Studiul proceselor de emisie a metalelor grele în ape curgătoare utilizând tehnici de modelare matematică

(Study of Heavy Metals Emissions in Rivers Using Mathematical Models)

Monica-Cristina CARA

Supervisor prof. D. M. Perju

Contribuții la studiul îmbunătățirii indicatorilor de calitate ai mierii de albine

(Contributions to the Study of Improving Honey Quality Indicators Using Mathematical Models)

Anca URSOIU

Supervisor prof. F. Peter

Creșterea eficienței catalitice și stabilității operaționale și termice a lipazelor prin imobilizare, folosind metode bazate pe tehnica sol-gel

(Increasing the Catalytic Efficiency, Operational and Thermal Stability of Lipases by Immobilization Using Sol-Gel Techniques)

Anamaria-Simona SCHEAU (BACIU)

Supervisor prof. G. Burtică

Electrochemical Detection of Certain Specific Pollutants from Water Using Nanostructured Carbon-Based Composite Electrodes

Sorina MOȚOC

Supervisor prof. G. Burtică

Electrochemical Degradation and Detection Methods of Pharmaceuticals from Water Using Carbon Based Electrodes

Adriana-Ileana REMEȘ

Supervisor prof. G. Burtică

Multi-Wall Carbon Nanotubes-Based Composite Electrodes for Electroanalysis Applications

Liliana-Marinela ȘTEFAN

Supervisor prof. L.M. Rusnac

Polimeri biodegradabili pe bază de monozaharide

(Contributions to Target Detection in Wireless Sensor Networks)

Liliana-Andreea COLAR

Supervisor prof. R. Pode

Utilizarea unor catalizatori de tip zeolitic pentru epurarea avansată a unor efluenți industriali

(Zeolitic Type Catalysts Used in the Advanced Treatment of some Industrial Effluents)

Alina-Ramona CROITORU

Supervisor prof. C. Davidescu

Utilizarea lipazelor imobilizate pentru sinteza esterilor de oligo- și polizaharide

(Application of Immobilized Lipases in the Synthesis of Oligo- and Polysaccharide Esters)

Civil Engineering

Tamas DENCSAK

Supervisor prof. C. Bob

Sustainability of Constructions. Special Aspects of Concrete Structures

Oliver PFANN

Supervisor prof. G. Crețu

Cercetări privind captarea emisiilor și impactul acestora asupra apelor de suprafață

(Researches Concerning the Capturing of Emissions and Their Impact on Surface Water)

Adrian RITI

Supervisor prof. G. Crețu

Contribuții la diminuarea impactului amenajărilor în ecosistemele din zonele miniere

(Contributions in Diminishing the Arrangements Impact Upon Mining Areas Ecosystems)

Laura ALEXOAI

Supervisor prof. G. Crețu

Studiul privind integrarea zonelor umede în managementul inundațiilor

(Research Concerning the Integration of Wetlands Into Flood Management)

Laura-Ioana PĂRCĂLAB

Supervisor prof. G. Rogobete

Sociologia dezastrelor și metode ingineresti pentru diminuarea impactului în zonele miniere abandonate din Banat

(Disaster Sociology and Engineering Methods to Reduce the Impact in Abandoned Mining Areas From Banat)

Lucreția BOCIORT

Supervisor prof. G. Popa

Studiul tranzitării debitelor de apă pe râurile îndiguite cu acumulări laterale

(Study of Flow Dynamics on Rivers with Lateral Storage Capacity)

Sebastian DORHOI

Supervisor prof. I. Borza

Contribuții privind studiul teoretic și practic corelat cu modelarea parametrilor de confort din clădirile de învățământ climatizate

(Theoretical and Practical Contributions Correlated with Modelling the Indoor Comfort Parameters in Educational Buildings with Air Conditioning System)

Loredana BALIGA

Supervisor prof. I. David

Studiul reducerii poluării acviferelor prin integrarea proceselor de atenuare naturală

(Study of Groundwater Pollution Reduction by Integrating Natural Attenuation Processes)

Maria-Roberta GRIDAN

Supervisor prof. M. Marin

Folosirea metodelor moderne de topografie pentru urmărirea comportării construcțiilor speciale

(Monitoring Special Constructions Behaviour Using Topographical Modern Methods)

Vinicius PRECUPAȘ
Supervisor prof. M. Ivan
Analiza comportării neliniare a cupolelor metalice
(Nonlinear Behaviour Analysis of Steel Domes)

Silvia-Mihaela ROMINU
Supervisor prof. R. Băncilă
Contribuții pentru îmbunătățirea robusteții structurilor în proiectarea și reabilitarea construcțiilor
(Contributions Regarding the Improvement of the Robustness in the Design and Rehabilitation of Structures)

Gabriela GHERMAN
Supervisor prof. T. E. Man
Aspecte actuale și de perspectivă ale dezvoltării rurale durabile a comunei Sasca Montană, Județul Caraș-Severin
(Current Issues and Perspectives of Sustainable Rural Development of Sasca Montana Commune, Caraș-Severin County)

Alina GABOR
Supervisor prof. T. E. Man
Eficiențizarea și re tehnologizarea sistemului de irigații Fântânele-Șag Arad
(The Optimisation and Etechnologization of Fantanele-Șag Arad Irrigation System)

Alexandru-Adrian FABIAN
Supervisor prof. V. Stoian
Study on the Performances of Composite Steel Concrete Structural Shear Walls Under Lateral Loads

Lucian-Attila BLAGA
Supervisor prof. R. Băncilă
Innovating Materials in Bridge Constructions Contribution to Constructions with Composite Fiber-Reinforced Materials

Industrial Engineering

Ramona-Cristina LASLĂU
Supervisor prof. A. Nichici
Investigarea proceselor de tăiere laser nd:YAG a materialelor compozite cu matrice polimerică
(Investigation on the Polymer Matrix Composite Materials Nd: YAG Laser Cutting Processes)

Aurel-Valentin BIRDEANU
Supervisor prof. D. Dehelean
Dezvoltarea procedului de sudare hibrid LASER-(micro).WIG pulsat
(The Development of the Pulsed Laser-(Micro). Tig Hybrid Welding Process)

Grigore SEBEȘ
Supervisor prof. D. Dehelean
Dezvoltarea microîmbinărilor pentru fabricarea dispozitivelor electromecanice MEMS
(Development of Microjoining Processes for the Manufacturing of Micro Electromechanical Devices)

Ioan-Dorian ȘTEF
Supervisor prof. G. Drăghici
Dezvoltarea produsului în contextul fabricii digitale
(Product Development in the Context of Digital Factory)

Adrian ORIȚA

Supervisor prof. G. Drăghici

Metodologie de concepție integrată a produselor în context PLM
(Integrated Product Design Methodology in PLM Context)

Adrian BIRLAN

Supervisor prof. M. Jădăneanț

Studiul proceselor de ambutisare adâncă utilizând metode numerice
(Study of the Deep Drawing Using Numeric Methods)

Cristian CIOANĂ

Supervisor prof. T. Iclănzan

Metode de integrare a tehnicii Reverse Engineering în concepția, fabricația și controlul dimensional al pieselor injectate din materiale polimerice
(Methods of Integrating Reverse Engineering in Design, Manufacturing and Dimensional Control of Molded Polymer Parts)

Iancu-Serban ȘERBAN

Supervisor prof. T. Iclănzan

Studiul activării ultrasonice a proceselor de curgere a materialelor polimerice termoplastice cu aplicare la procedeele de microinjectare și injectare a pieselor cu pereți subțiri
(Ultrasonic Activation Study of Thermoplastic Polymers' Flow Process in Microinjection Molding and Injection of Thin Walled Parts)

Sebastian CAPOTESCU

Supervisor prof. C.D. Dumitrescu

Influența facilităților asupra performanțelor în spațiile destinate birourilor
(The Influence of Facilities on Office Performance)

Mechanical Engineering

Mihai VOINESCU

Supervisor prof. A. Davidescu Supervisor prof. G. Savi

Contribuții la creșterea performanțelor protezelor transtibiale
(Contributions to Increasing the Performances of Transtibial Prostheses)

Raluca-Elena SOFRONIA

Supervisor prof. A. Davidescu

Supervisor prof. G. Savi

Contribuții la utilizarea dispozitivelor haptice în aplicațiile biomedicale
(Contributions to the Use of Haptic Devices in Biomedical Application)

Marian DOBRIN

Supervisor prof. C. Ungureanu

Supervisor prof. I. Ionel

Cercetări privind elaborarea unui model pentru restructurarea durabilă a sectorului de producere a energiei electrice
(Research Activities Regarding the Sustainable Restructuring Model of the Electricity Generation Sector)

Ioan-Dumitru HITICAȘ

Supervisor prof. D. Iorga

Studii și cercetări privind efectele reglajelor unui motor cu injecție de benzină, asupra performanțelor energetice și a poluării mediului

(Studies and Researches Regarding the Adjustment Effects of a Gasoline Injection Engine on Energy Performance and Environmental Pollution)

Todor NICHIFOR

Supervisor prof. F. Gyiulai

Adaptarea agregatelor aeroelectrice de mică putere la oferta amplasamentului
(The Adaptation of Small Power Wind Turbines to the Offer of the Site)

Alin-Dan JURCHELA

Supervisor prof. I. Bordeășu

Supervisor prof. I. Mitelea

Cercetări asupra eroziunii produse prin cavitație vibratorie la oțelurile inoxidabile cu conținut constant în crom și variabil în nichel

(Research on Erosion Produced by Vibratory Cavitation to Stainless Steels with Constant Chromium Content and Variable Nickel Content)

Marilena-Georgeta TĂRBAȚ

Supervisor prof. I. Nicoară

Supervisor prof. I. Grozescu

Contribuții privind proiectarea științifică a experimentelor de sinteza a nanocristalelor (TiO₂)

(Contributions Regarding the Scientific Design of Testing Synthesis a Nanocrystals (TiO₂))

Florin-Mihai IACOBESCU

Supervisor prof. I. Ionel

Cercetări teoretice și experimentale privind cogenerarea cu motor cu aprindere prin scânteie, funcționând cu GPL

(Theoretical and Experimental Research Regarding Combined Heat and Power (CHP) on an Ignition Engine Running With LPG)

Delia-Gabriela CĂLINOIU

Supervisor prof. I. Ionel

Cercetări privind influența aerosolilor asupra potențialului energetic solar prin investigarea transferului radiativ în atmosferă

(Research Regarding the Influence of Aerosols Upon Solar Energy Potential by Applying the Atmospheric Radiative Transfer)

Gheorghe-Cătălin NISULESCU

Supervisor prof. I. Ionel

Cercetări aplicând spectrometria și termografia pentru determinarea concentrațiilor de SO₂ emise de centralele funcționând pe cărbune

(Research by Applying Spectroscopy and Thermography for the Determination of the SO₂ concentrations Emitted by Coal Power Plants)

Lorand KUN

Supervisor prof. I. Dumitru

Modelări și simulări în oboseală multiaxială

(Modeling and Simulation of Multiaxial Fatigue)

Teodora-Georgiana IOANOVICI

Supervisor prof. L. Betreteu

Supervisor prof. P. Hivart

Supervisor prof. F. Monchau

Contribuții la sinteza de hidroxiapatită dopată cu magneziu și cercetări asupra proprietăților mecanice în vederea utilizării ei în implanturi osoase

(Contributions to Magnesium Substituted Hydroxyapatite Synthesis and Analysis of its Mechanical Properties for Bone Implants Applications)

Cristian SAFTESCU-JESCU

Supervisor prof. L. Bereteu

Studiul implanturilor de coloana vertebrală lombară, în vederea integrării anatomice prin metode și tehnologii moderne

(On the Study of Lumbar Spine Implants for Anatomical Integration Through Modern Technologies)

Dan-Andrei ȘERBAN

Supervisor prof. L. Marșavina

Experimental Investigations and Numerical Simulations of the Mechanical Behaviour of Polyamides

Gheorghică GÎNGA

Supervisor prof. L. E. Anton

Analiza experimentală și numerică a funcționării pompelor centrifuge de acumulare
(Experimental and Numerical Investigations on Storage Pump Operation)

Mihaela-Elena BUCULEI

Supervisor prof. M. Nagi

Studii și cercetări privind pregătirea termică a combustibilului lichid neconventional pentru folosirea la motoare cu aprindere prin comprimare cu injecție directă

(Studies and Researches Regarding the Use of Unconventional Biofuel for Diesel Engines)

Ioan-Daniel CĂRĂBAȘ

Supervisor prof. M. Nagi

Studii și cercetări privind performanțele termice și fluidodinamice ale schimbatoarelor de caldură cu nervuri discontinue, dispuse alternant

(Studies and Research Regarding Thermal and Fluid Dynamics Performance of Heat Exchangers with Alternately Displaced, Discontinuous Wavy Fins)

Constantin TĂNASĂ

Supervisor prof. R. Susan-Resiga

Flow-feedback pentru reducerea fluctuațiilor de presiune în difuzorul conic al turbinelor hidraulice

(Flow-Feedback for Mitigation of Pressure Fluctuations in the Conical Diffuser of Hydraulic Turbines)

Hannelore-Elfride RUS

Supervisor prof. T. D. Babeu

Investigarea ruperii fragile în modul mixt pe materiale poliuretanic

(Investigation of Mixed Mode Fracture on Polyurethane Materials)

Mihaela-TILNEAC

Supervisor prof. V. Dolga

Contribuții la utilizarea roboților în agricultură pentru aplicații de combatere a buruienilor

(Contributions on Using Robots in Agriculture for Weed Control Applications)

Mihai-Alin BÎTEA

Supervisor prof. V. Dolga

Analiza și sinteza teoretică și experimentală a unui mecatronic autonom mobil

(Theoretical and Experimental Analysis and Synthesis of a Mechatronic Mobile Autonomous System)

Materials Engineering

Sanjay KUMAR

Supervisor prof. I. Grozescu

Synthesis and Characterization of ACRO₂ (A=Cu, Ag) Delafossite Compounds

Iasmina MIRON

Supervisor prof. I. Grozescu

Sinteza și caracterizarea aluminatului de zinc nedopat și dopat cu ioni ai metalelor de tranziție și ai pământurilor rare

(Synthesis and Characterization of Inc Aluminate Undoped and Doped with Transition Metal and Rare Earth Ions)

Kiran-Kumar BOKINALA

Supervisor prof. I. Grozescu

Synthesis and Characterizations of Layered Cobalt Oxides ACOO₂ (A= Na, Li, Pt and Pd) for Thermoelectric Applica

Cristina CIOBANU

Supervisor prof. I. Grozescu

Studii privind rolul și mecanismul de acțiune al aditivilor reținători de apă din mortarele uscate

(Studies on the Role and Action Mechanism of Water Retention Additives in Dry Mortars)

Nicolaie VĂRZARU

Supervisor prof. I. Mitelea

Studii și cercetări asupra procesului de sudare în curenți de înaltă frecvență a unor polimeri

(Studies and Researches of the High Frequency Welding Process for the Polymers)

Marcela-Elena DIMIAN

Supervisor prof. I. Mitelea

Supervisor prof. I. Bordeășu

Cercetări asupra rezistenței la cavitație a aliajelor de titan cu structură bifazică

(Research on the Cavitation Resistance of Titanium Alloys with Biphasic Structure)

Claudia-Mariana DOROHAI

Supervisor prof. I. Mitelea Supervisor prof. V.A. Șerban

Cercetări asupra procesului de sudare electrică prin presiune a aliajelor cu memorie a formei din familia FeMnSi și CuZnAl

(Researches on the Welding Pressure Process of the FeMnSi and CuZnAl Shape Memory Alloys)

Cristian FĂNICĂ

Supervisor prof. I. Ilca

Influența structurii arborilor cotiți de dimensiuni mari, asupra durabilității lor în exploatare

(The Influence of Large Crankshafts Structure Upon Their Endurance in Operation)

Mariana SUBA

Supervisor prof. P. Krawczak Supervisor prof. I. Lazău

Sinteza aluminatilor și feritaluminatilor alcalino-pământoși prin metoda combustie

(Alkaline-Earth Aluminates and Feritte-Aluminates Synthesis by Combustion Method)

Florin-Viorel DRĂGOI

Supervisor prof. T. Heput

Cercetări privind reducerea conținutului de gaze din oțelurile elaborate și tratate pe fluxul tehnologic E.B.T.- L.F.

(Researches Regarding the Reduction of the Gas Content from the Steels Produced and Treated on the E.B.T.- L.F. Technological Flow)

Dragoș BUZDUGAN

Supervisor prof. V.A. Șerban

Aliaje amorfe feromagnetice masive cu aplicabilitate la realizarea ecranelor magnetice

(Ferromagnetic Bulk Amorphous Alloys with Magnetic Shielding Applicability)

Ioan-Florin SECOȘAN

Supervisor prof. V.A. Șerban

Supervisor prof. W. Brandi

Wear and Corrosion Behaviour of HVOF Cermets Coatings Sprayed on Inner Cylindrical Surfaces

Scientific conferences held in 2012

- *International Symposium on Electronics and Telecommunications - ETC 2012 (tenth edition)*

Organizers: Faculty of Electronics and Telecommunications Engineering

<http://www.etc.upt.ro/isetc2012/home.php>

- *Conference on Motor Vehicle & Transportation - MVT 2012*

Organizers: Department of Mechanical Machines, Equipment and Transportation

<http://www.arupt.ro/mvt>

- *XIII-th International Conference of Mathematics and its Applications*

Organizers: Department of Mathematics

<http://www.mat.upt.ro/ICMA2012/index.htm>

- *REHVA Annual Conference and Meeting on Technology and Energy Retrofitting*

Organizers: Faculty of Civil Engineering

<http://www.dosetimpex.ro/rehva-am2012/>

- *International Conference "Building Services and Ambient Comfort"*

Organizers: Department of Civil Engineering and Equipment

<http://www.ct.upt.ro/avizier.htm>

- *SACI 2012 IEE 7th International Symposium on Applied Computational Intelligence and Informatics*

Organizers: Faculty of Automation and Computer Science

<http://conf.uni-obuda.hu/saci2012/>

- *13th International Conference on Optimization of Electrical and Electronic Equipment*

Organizers: Faculty of Electrical and Power Engineering

<http://www.info-optim.ro/index.php>

Events related to the research field held in 2012

- *International Symposium on "Poverty - A Challenge for Sustainable Development"*
Organizers: Faculty of Architecture
- *Symposium on "Education in the future tense" (VII-th edition)*
Organizers: Department of Teacher Training
- *International Symposium on "Environmental Protection & Ecological Education"*
Organizers: Faculty of Chemistry and Environmental Engineering
- *Student Symposium "Challenges of the teaching profession" (second edition)*
Organizers: Department of Teacher Training
- *Virtual enterprise, entrepreneurship exercise tool*
Organizers: Faculty of Engineering in Hunedoara
- *Strategy and achievements for the creation of motorways in Romania*
Organizers: Department of Overland Communication Ways, Foundations and Cadastral Survey
- *CONNECTIONS VII - 7th International Workshop on connections in Steel Structures*
Organizers: Department of Steel Structures and Structural Mechanics
- *Timsoara's Academic Days "Hydrotechnical Engineering in Theory and Practice"*
Organizers: Department of Hydrotechnical Engineering
- *International Roundtable "Formation Professionnelle a distance dans l'archeologie industrielle"*
Organizers: Faculty of Architecture
- *Academic and professional translation*
Organizers: Faculty of Communication Sciences
- *Implementation of new techniques to support geodetic education. Importance of MEDIA laboratories*
Organizers: Department of Overland Communication Ways, Foundations and Cadastral Survey
- *Communication between the real and virtual*
Organizers: Faculty of Communication Sciences and E-Learning Centre

Transaction on Automatic Control and Computer Science, Issue 1, 2, 3, 4
<http://www.ac.upt.ro/journal/>

Transaction on Chemistry and Environmental Engineering, Issue 1
www.chemicalbulletin.ro

Transaction on Electronics and Communications, Issue 1, 2
<http://www.tc.etc.upt.ro/bulletin/>

Transaction on Electrical Engineering, Issue 1, 2, 3, 4
<http://www.jee.ro/index.php>

Transaction on Hydrotehnics, Issue 1, 2
<http://www.ct.upt.ro/buletinhidro/index.htm>

Transaction on Physical Education and Sport, Issue 1, 2
http://www.efs.upt.ro/buletin_stiintific.php

Transaction on Modern Languages, Issue 1, 2
<http://www.cls.upt.ro/cercetare/buletinul-stiintific>

Transaction on Mathematics and Physics, Issue 1, 2
http://www.upt.ro/cercetare/mate_fizica.php

Transaction on Mechanics, Issue 1, 2 and Special Issue 1
<http://eng.upt.ro/buletin/issuesphp.html>

Annals of Faculty Engineering Hunedoara
International Journal of Engineering, Issue 1, 2, 3
<http://annals.fih.upt.ro/issues.html>

ACTA Technica Corviniensis, Tome V, Issue 1, 2, 3, 4
<http://acta.fih.upt.ro/>

Academic Journal of Manufacturing and Engineering, Tome 10, Issue 1, 2, 3, 4
<http://eng.upt.ro/auif/journal.html>

1. S. C., Agarlita; I., Boldea; F., Blabjerg; *High-Frequency-Injection-Assisted "Active-Flux"-Based Sensorless Vector Control of Reluctance Synchronous Motors, with Experiments from Zero Speed*, IEEE Transactions on Industry Applications, vol. 48, no. 6, pp. 1931-1939, 2012;
2. A., Amaricai; O., Boncalo; *Implementation of Very High Radix Division in FPGAs*, Electronics Letters, vol. 48, no. 18, pp. 1107-1108, 2012;
3. A., Anastasiadis; M., Moșoarca; V., Gioncu; *Prediction of Available Rotation Capacity and Ductility of Wide-Flange Beams: Part 2: Applications*, Journal of Constructional Steel Research, vol. 68, no. 1, pp. 176-191, 2012;
4. C., Andronache; A., Socalici; T., Heput; E., Popa; *Research on the Influence of Steel Ingot Solidification Process Control on the Tenacity Characteristics*, Metalurgia International, vol. 17, no. 9, pp. 234-238, 2012;
5. C. P., Arieșanu; *A Hamilton-Poisson Model of the Chen-Lee System*, Journal of Applied Mathematics, 2012;
6. C. P., Arieșanu; *An Underactuated Drift-Free Left Invariant Control System on a Specific Lie Group*, Journal of Applied Mathematics, 2012;
7. M. Averyanova; E. Cicala; P. Bertrand; D., Grevey; *Experimental Design Approach to Optimize Selective Laser Melting of Martensitic 17-4 Ph Powder; Part I - Single Laser Tracks and First Layer*, Rapid Prototyping Journal, vol. 18, no. 1, pp. 28-37, 2012;
8. S., Babeti; *Black Holes and Other Solutions in Commutative and Noncommutative Gauge Theory of Gravitation*, Romanian Journal of Physics, vol. 57, no. 5, pp. 785-792, 2012;
9. A., Baciu; A., Remeș; E., Ilinoiu; F., Manea; S. J., Picken; J., Schoonman; *Carbon Nanotubes Composite for Environmentally Friendly Sensing*, Environmental Engineering and Management Journal, vol. 11, no. 2, pp. 239-246, 2012;
10. A. C., Bala; C., Grecea; F. M., Brebu; V., David; C. I., Bota; *Monitoring Mining Dumps in Relation With Environmental Protection*, Journal of Environmental Protection and Ecology, vol. 13, no. 4, pp. 2433-2438, 2012;
11. C., Bandas; C., Lazau; P., Sfirloaga; F., Manea; R., Pode; *Microwave-Assisted Hydrothermal Synthesis of Composite Materials Based on Zeolite-TiO₂ Nanocrystals*, Environmental Engineering and Management Journal, vol. 11, no. 3, pp. 511-516, 2012;
12. M., Barbu; M., Stefanescu; M., Stoia; G., Vlase; P., Barvinschi; *New Synthesis Method for M(II) Chromites/Silica Nanocomposites by Thermal Decomposition of Some Precursors Formed Inside the Silica Gels*, Journal of Thermal Analysis and Calorimetry, vol. 108, no. 3, pp. 1059-1066, 2012;
13. A., Bej; I., Bordeășu; T., Milos; R., Badarau; *Considerations Concerning the Mechanical Strength of Wind Turbine Blades Made of Fiberglass Reinforced Polyester*, Materiale Plastice, vol. 49, no. 3, pp. 212-218, 2012;
14. D., Belega; D., Dallet; D., Petri; *Accuracy of the Normalized Frequency Estimation of a Discrete-Time Sine-Wave by the Energy-Based Method*, IEEE Transactions on Instrumentation and Measurement, vol. 61, no. 1, pp. 111-121, 2012;

- 15.** D., Belega; D., Dallet; D., Petri; *Statistical Description of the Sine-Wave Frequency Estimator Provided by the Interpolated DFT Method*, Measurement, vol. 45, no. 1, pp. 109-117, 2012;
- 16.** D., Belega; D., Petri; *Accuracy Analysis of the Amplitude Estimation of a Sine-Wave by the Energy-Based Method Using the Direct and Indirect Procedures*, Measurement, vol. 45, no. 9, pp. 2264-2274, 2012;
- 17.** D., Belega; D., Petri; D., Dallet, *Noise Power Estimation by the Three-Parameter and Four-Parameter Sine-Fit Algorithms*, IEEE Transactions on Instrumentation and Measurement, vol. 61, no. 12, pp. 3234-3240, 2012;
- 18.** V. N., Bercean; V., Badea; C., Deleanu; A., Nicolescu, *New 1h-1-alkyl-6-methyl-3-phenyl-7-phenylazo-pyrazolo[5,1-C][1,2,4]triazoles through regioselective alkylation of ih-6-methyl-3-phenyl-7-*, Central European Journal of Chemistry, vol. 10, no. 2, pp. 373-379, 2012
- 19.** A. V., Birdeanu; C., Ciuca; A., Puicea; *Pulsed Laser-(Micro) Tig Hybrid Welding: Process Characteristics*, Journal of Materials Processing Technology, vol. 212, no. 4, pp. 890-902, 2012;
- 20.** A., Birlan; *The Study of Dynamic State of Deformation During a Cold Plastic Deformation Process in the Case of Deep-Drawing*, Metalurgia International, vol. 17, no. 4, pp. 132-135, 2012;
- 21.** A., Birlan, *Dynamic Stress Study During Deep-Drawing Process*, Metalurgia International, vol. 17, no. 4, pp. 86-89, 2012;
- 22.** C., Bob; T., Dencsak; C., Tanasie; I., Balcu, *Contributions Regarding the Evaluation of the Ability of Concrete to Bind CO₂ by Carbonation*, Revista Română de Materiale - Romanian Journal of Materials, vol. 42, no. 4, pp. 370-380, 2012;
- 23.** F., Borcan; C., Bolcu; N., Filimon; G., Bandur; *The Synthesis and Characterization of the Polyurethanes with Antimicrobial Properties*, E-Polymers, vol. 2012 no. 080, pp. 1-8, 2012;
- 24.** S., Borcanescu; I., Lazau; C., Pacurariu; A., Jurca; *Mullite Synthesis by Unconventional Methods*, Revista Română de Materiale - Romanian Journal of Materials, vol. 42, no. 4, pp. 364-369, 2012;
- 25.** C. M., Bortun; A., Cernescu; L., Ardelean, *Mechanical Properties of Some Dental Resins in Wet and Dry Conditions*, Materiale Plastice, vol. 49, no. 1, pp. 5-8, 2012;
- 26.** A. I., Bosioc; R., Susan-Resiga; S., Muntean; C., Tanasa, *Unsteady Pressure Analysis of a Swirling Flow with Vortex Rope and Axial Water Injection in a Discharge Cone*, Journal of Fluids Engineering Transactions of the ASME, vol. 134, no. 8, 2012;
- 27.** C., Bratu; A., Ogodescu; L., Ardelean; C., Sinescu; C., Matei; M., Tampa; D., Dodenciu; G., Drăgănescu; L. C., Rusu; *Laser Micro Spectral Investigation of the Orthodontic Attachments*, Revista de Chimie, vol. 63, no. 3, pp. 272-274, 2012;
- 28.** F. M., Brebu; M., Marin; A.C., Bala, *Monitoring of the Building Energy in Connection with the Requirements of the Sustainable Urban Development and of the Environmental Protection*, Journal of Environmental Protection and Ecology, vol. 13, no. 4, pp. 2439-2444, 2012;
- 29.** L., Bukkosi; G., Thalmaier; C., Codrean; P., Pascuta; I., Vida-Simiti, *Obtaining and Characterization of Ni-Zr Type Amorphous Tapes*, Optoelectronics and Advanced Materials-Rapid Communications, vol. 6, no. 9, pp. 814-817, 2012;
- 30.** A., But; J., Le Notre; E. L., Scott; R., Wever; J. P. M., Sanders, *Selective Oxidative Decarboxylation of Amino Acidst to Produce Industrially Relevant Nitriles by Vanadium Chloroperoxidase*, Chemsuschem, vol. 5, no. 7, pp. 1199-1202, 2012;

- 31.** L., Cadariu; L., Gavruța; P., Gavruța, *Fixed Point and Generalized Hyers-Ulam Stability*, Abstract and Applied Analysis, 2012;
- 32.** L., Cadariu; Gavruța; P., Gavruța, *Weighted Space Method For the Stability of Some Nonlinear Equations*, Applicable Analysis and Discrete Mathematics, vol.6, no.1, pp.126-139, 2012;
- 33.** L., Cadariu; V., Radu, *A General Fixed Point Method for the Stability of the Monomial Functional Equation*, Carpathian Journal of Mathematics, vol. 28, no. 1, pp. 25-36, 2012;
- 34.** L., Calin; I., Ionel; F., Popescu; N., Lontis, *Impact Studies of the Air-Flue Gases Mixture in the Corn Drying Process*, Journal of Environmental Protection and Ecology, vol. 13, no. 2, pp. 435-441, 2012;
- 35.** D., Calinoiu; I., Ionel; G., Trif-Tordai, *Research Regarding Aerosol Properties of the Grimsvotn Ash by Applying Sun Photometry*, Revista de Chimie, vol. 63, no. 8, pp. 846-850, 2012;
- 36.** M. C., Cara; G. A., Dumitrel; M., Glevitzky; D., Perju, *Stability of Tetracycline Residues in Honey*, Journal of the Serbian Chemical Society, vol. 77, no. 7, pp. 879-886, 2012;
- 37.** B., Căruntu; C., Bota, *Approximate Polynomial Solutions for Nonlinear Heat Transfer Problems Using the Squared Remainder Minimization Method*, International Communications in Heat and Mass Transfer, vol. 39, no. 9, pp. 1336-1341, 2012;
- 38.** V., Cebrucean; I., Ionel, *CO₂ Capture from Flue Gas with Monoethanolamine*, Revista de Chimie, vol. 63, no. 7, pp. 678-681, 2012;
- 39.** A. E., Cioabla; I., Ionel; G. A., Dumitrel; P., Negrea; V., Pode, *Biogas Production Through Anaerobic Digestion of Some Agro-Industrial Residues*, Revista de Chimie, vol. 63, no. 6, pp. 629-632, 2012;
- 40.** A.E., Cioabla; I., Ionel; G.A., Dumitrel; F., Popescu, *Comparative Study on Factors Affecting Anaerobic Digestion of Agricultural Vegetal Residues*, Biotechnology for Biofuels, vol.2012, no.5, pp. 39, format electronic, 2012;
- 41.** A. E., Cioabla; I., Ionel; F., Popescu, *Comparative Results in Biogas Production Using Municipal Biodegradable Waste for Green Gas Emissions Reduction*, Journal of Optoelectronics and Advanced Materials, vol. 14, no. 03, pp. 329-335, 2012;
- 42.** A. E., Cioabla; G.D., Tordai; P., Rotaru; M., Socaciu; I., Ionel, *Experimental Approach of Co-Firing and Anaerobic Fermentation of Biomass and Coal, and Their Thermochemical Properties*, Journal of Thermal Analysis and Calorimetry, vol. 110, no. 1, pp. 395-403, 2012;
- 43.** M., Ciopec; C. M., Davidescu; A., Negrea; I., Grozav; L., Lupa; C., Muntean; P., Negrea; A., Popa; *Statistical Optimization of Chromium Ions Adsorption on Dehpa-Impregnated Amberlite Xad7*, Environmental Engineering and Management Journal, vol. 11, no. 3, pp. 525-531, 2012;
- 44.** M., Ciopec; C. M., Davidescu; A., Negrea; I., Grozav; L., Lupa; P., Negrea; A., Popa; *Adsorption Studies of Cr(III) Ions From Aqueous Solutions by Dehpa Impregnated onto Amberlite Xad7-Factorial Design Analysis*, Chemical Engineering Research & Design, vol. 90, no. 10, pp. 1660-1670, 2012;
- 45.** L. A., Colar; L., Cocheci; E. C., Ilinoiu; F., Manea; C., Orha; R., Pode; *Adsorption of Ry 125 Dye from Aqueous Solution on a Silver Doped TiO₂ Modified Clinoptilolite*, Environmental Engineering and Management Journal, vol. 11, no. 8, pp. 1375-1381, 2012;
- 46.** L. A., Colar; E. C., Ilinoiu; F., Manea; R., Pode; C., Lazau; *Photocatalytic Activity of a Silver Doped Tio₂ Modified Zeolite in the Degradation of Reactive Yellow 125 Azo Dye*, Environmental Engineering and Management Journal, vol. 11, no. 1, pp. 61-68, 2012;

- 47.** D., Crăciun; L., Pitulice; A., Ciorsac; V., Ostafe; A., Isvoran; *Proteins Surface Roughness Analysis. Comparison of Crystallographic and Nmr Structures*, Romanian Reports in Physics, vol. 64, no. 1, pp. 116-126, 2012;
- 48.** C. M., Craciunescu; F. M. B., Fernandes; *Graded Transitions in Ni-Ti Shape Memory Alloys Processed by Severe Plastic Deformation*, Functional Materials Letters, vol. 5, no. 4, 2012;
- 49.** A., Crișan; V., Ungureanu; D., Dubina; *Behaviour of Cold-Formed Steel Perforated Sections in Compression. Part 1-Experimental Investigations*, Thin-Walled Structures, vol. 61, no. 45, pp. 86-96, 2012;
- 50.** A., Crișan; V., Ungureanu; D., Dubina; *Behaviour of Cold-Formed Steel Perforated Sections in Compression: Part 2-Numerical Investigations and Design Considerations*, Thin-Walled Structures, vol. 61, pp. 97-105, 2012;
- 51.** E., Crișan; L., Vilceanu; V., Putan; M., Ardelean; *Experiments Regarding to Crushing and Fissuring Resistance for Briquettes from Various Type of Pulverous Ferrous Waste*, Metalurgia International, vol. 17, no. 10, pp. 80-87, 2012;
- 52.** M. M., Crișan; D., Ioan; *Current Status of Groundwater Monitoring and Its Future in Arad*, Journal of Environmental Protection and Ecology, vol. 13, no. 4, pp. 2104-2111, 2012;
- 53.** D. G., Cristea; M. E., Basch; H., Ben-Yoav; V., Tiponut; Y., Shacham-Diamand; *Universal Signal Conditioning System For Amperometric Sensors*, Advances in Electrical and Computer Engineering, vol. 12, no. 15, pp. 19-24, 2012;
- 54.** M. F., Crivineanu; G. A., Dumitrel; D. S., Perju; C., Jinescu; A., Negrea; *The Influence of Environmental Factors on Sedimentation Dynamics of Heavy Metals in Surface Waters*, Revista de Chimie, vol. 63, no. 10, pp. 1051-1055, 2012;
- 55.** M. F., Crivineanu; D., Perju; G. A., Dumitrel; D. S. Perju; *Mathematical Models Describing the Emission and Distribution of Heavy Metals in Surface Waters*, Revista de Chimie, vol. 63, no. 4, pp. 435-439, 2012;
- 56.** R., Croitoru; F., Fitigau; L. A. M., Van Den Broek; A. E., Frissen; C. M., Davidescu; C. G., Boeriu; E., Peter, *Biocatalytic Acylation of Sugar Alcohols by 3-(4-Hydroxyphenyl) Propionic Acid*, Process Biochemistry, vol. 47, no. 12, pp. 1894-1902, 2012;
- 57.** D. I., Curiac; C., Volosencu; *Chaotic Trajectory Design for Monitoring an Arbitrary Number of Specified Locations Using Points of Interest*, Mathematical Problems in Engineering, 2012;
- 58.** D. I., Curiac; C., Volosencu, *Ensemble Based Sensing Anomaly Detection in Wireless Sensor Networks*, Expert Systems with Applications, vol. 39, no. 10, pp. 9087- 9096, 2012;
- 59.** D., Dan, *Experimental Testson Seismically Damaged Composite Steel Concrete Walls Retrofitted with Cfrp Composites*, Engineering Structures, vol. 45, pp. 338- 348, 2012;
- 60.** I., David; M., Pișleaga; M., Vișescu; C., Ștefanescu; C., Iliuță; *Numerical Experiment to Determine the Influence of the Particle Number of the Random Walk Simulation Method for Heat and Pollutant Transport in the Aquifer*, Journal of Environmental Protection and Ecology, vol. 13, no. 3A, pp. 1989-1996, 2012;
- 61.** V., David; *Generation of Digital Terrain Model for a Flood Area*, Journal of Environmental Protection and Ecology, vol. 13, no. 2A, pp. 1124-1130, 2012;
- 62.** V., David; *Hazard Mapping for the Natural Disasters*, Journal of Environmental Protection and Ecology, vol. 13, no. 2A, pp. 913-919, 2012;
- 63.** V., David; M., Sturza; A. C., Bala; *Creation of Geodatabase on the Implementation Iacs-Lpis in Romania*, Journal of Environmental Protection and Ecology, vol. 13, no. 3A, pp. 2035-2039, 2012;

- 64.** A., De Sabata; L. Matekovits; *Electromagnetic Bandgap Solution for Mitigation of Parallel-Plate Noise in Power Distribution Networks*, Microwave and Optical Technology Letters, vol. 54, no. 7, pp. 1689-1692, 2012;
- 65.** A., De Sabata; L. Matekovits; *Reduced Complexity Biasing Solution for Switched Parallel Plate Waveguide with Embedded Active Metamaterial Layer*, Journal of Electromagnetic Waves and Applications, vol. 26, no. 14-15, pp. 1828-1836, 2012;
- 66.** A., De Sabata; L. Matekovits; *Unit-Cell Geometry in Stripline Technology Featuring Sequential Band-Gaps Between Every Two Consecutive Modes*, IEEE Antennas and Wireless Propagation Letters, vol. 11, pp. 97-100, 2012;
- 67.** B., Demetrescu; R. D. Radu; R. Radu; *Division Spatial Urban Planning of an Area. Case Study - the Sport and Recreation Facilities in Timișoara*, Journal of Environmental Protection and Ecology, vol. 13, no. 4, pp. 2371-2379, 2012;
- 68.** A., Diaconu; W., Russ; B., Klitzing; I., Ionel; *A New Way for Energy Supplying in the Beer Industry*, Journal of Environmental Protection and Ecology, vol. 13, no. 4, pp. 2331-2337, 2012;
- 69.** W. H., Diao; X. Mao; H. C., Zheng; Z. I., Xue; V., Gui; *Image Sequence Measures for Automatic Target Tracking*, Progress in Electromagnetics Research - PIER, vol. 130, pp. 447-472, 2012;
- 70.** M., Dobrin; C. E., Tomescu; I., Ionel; C., Florescu; *Make-up Water Treatment Within the Water Circuit of the Thermal Power Plants*, Revista de Chimie, vol. 63, no. 8, pp. 839-842, 2012;
- 71.** S., Dorhoi; I., Borza; M. I. Cinca; *Thermal Sensation in Wintertime for Faculty Classrooms. Distribution of Air Parameters for Two Type of Heating Systems*, Metalurgia International, vol. 17, no. 11, pp. 58-66, 2012;
- 72.** M. A., Dungan; L. I., Dungan; *Improvement of the Comfort of the Passengers in an Uic Passenger Car Type B-11 Using Basaltic Fibres Cloth Like Insulation Material on Ceiling*, Journal of Environmental Protection and Ecology, vol. 13, no. 4, pp. 2291-2301, 2012;
- 73.** G. Z., Eskandani; P., Gavruta; G.H., Kim;; *On the Stability Problem in Fuzzy Banach Space*, Abstract and Applied Analysis, 2012;
- 74.** E., Fagadar-Cosma; G., Fagadar-Cosma; M., Vasile; C., Enache; *Synthesis, Spectroscopic and Self-Assembling Characterization of Novel Photoactive Mixed Aryl-Substituted Porphyrin*, Current Organic Chemistry, vol. 16, no. 7, pp. 931-941, 2012;
- 75.** M., Fagadar-Cosma; M., Nouri; V. I., Crețu; M. V., Micea; *A Combined Optical Flow and Graph Cut Approach for Foreground Extraction in Videoconference Applications*, Studies in Informatics and Control, vol. 21, no. 4, pp. 413-422, 2012;
- 76.** C., Fănica; I., Ilca; *Considerationson Forging with Continuous Fibrous Structure and the Determination of Large Crankshafts Fatigue Strength*, Metalurgia International, vol. 17, no. 6, pp. 94-97, 2012;
- 77.** C., Fănica; I., Ilca; N., Potoceanu; *Considerationson Stress Modeling in the Crankshafts Through Finite Element Method*, Metalurgia International, vol. 17, no. 6, pp. 86-93, 2012;
- 78.** S., Fara; L., Fara; I., Luminosu; *Environmental Control in Isolated Mountain Area by Stand-Along PV System*, Journal of Environmental Protection and Ecology, vol. 13, no. 2A, pp. 821-826, 2012;
- 79.** I., Gavruta; *Frames for Operators*, Applied and Computational Harmonic Analysis, vol. 32, no. 1, pp. 139-144, 2012;

- 80.** C., Ghergheles; V., Ghergheles; T., Romocea; M. A., Roman; E., Pantea; M., Ion; A., Iovi; *Softening of Waste Geothermal Water Using Ion Exchange Resins for Environment Protection*, Journal of Environmental Protection and Ecology, vol. 13, no. 3, pp. 1553-1559, 2012;
- 81.** G., Gherman; A., Negrea; M., Ciopec; T. E., Man; M., Motoc; *Studies Concerning the Stabilization by Phytoremediation of Soils Degraded by Mining Activities*, Revista de Chimie, vol. 63, no. 3, pp. 324-329, 2012;
- 82.** E., Ghița; M., Nagy; I. D., Carabas; *Analysis Regarding the State of Thermal Stresses at Wheel-Rail Contact in the Railway Transport*, Journal of Environmental Protection and Ecology, vol. 13, no. 4, pp. 2140-2144, 2012;
- 83.** A., Ghosal; D., Iercan; C. M., Kirsch; T. A., Henzinger; Sangiovanni-Vincentelli, A; *Separate Compilation of Hierarchical Real-Time Programs Into Linear-Bounded Embedded Machine Code*, Science of Computer Programming, vol. 77, no. 2, pp. 96-112, 2012;
- 84.** V., Gioncu; M., Moșoarcă; A., Anastasiadis; *Prediction of Available Rotation Capacity and Ductility of Wide-Flange Beams: Part 1: Ductrot-M Computer Program*, Journal of Constructional Steel Research, vol. 69, no. 1, pp. 8-19, 2012;
- 85.** A., Girban; G., Girban; *On the Kinetic Equations of a Lithium-Ion Battery Model*, Comptes Rendus Mathematique, vol. 350, no. 19-20, pp. 917-920, 2012;
- 86.** C., Grecea; I., Ienciu, L., Dimen; A. C., Bala; L., Oprea; *Cadastral Support for an Efficient Town Planning in Timișoara, Romania*, Journal of Environmental Protection and Ecology, vol. 13, no. 2A, pp. 1099-1106, 2012;
- 87.** C., Grecea; I., Ienciu; L., Dimen; A. C., Bala; L., Oprea; *Impact of Surveying Engineering on the Environmental Protection Problems*, Journal of Environmental Protection and Ecology, vol. 13, no. 1, pp. 352-360, 2012;
- 88.** M. R., Gridan; S. F., Jianu; C., Grecea; *Implication of Forestry Cadastre in the National Strategy of Environmental Protection*, Journal of Environmental Protection and Ecology, vol. 13, no. 4, pp. 2283-2290, 2012;
- 89.** B., Groza; M., Minea; M., Cristea; P. S., Murvay; M., Iacob; *Protocol Vulnerabilities in Practice: Causes, Modeling and Automatic Detection*, Proceedings of the Romanian Academy Series A-Mathematics Physics Technical Sciences Information Science, vol. 13, no. 2, pp. 167-174, 2012;
- 90.** A., Grozav; Gh., Rogobete; *Environmental Effects of Exploitation of Iron Ore Deposit Boul Peak-the Poiana Rusca Mountains*, Journal of Environmental Protection and Ecology, vol. 13, no. 4, pp. 2130-2139, 2012;
- 91.** C. M., Gruescu; C. L., Ionescu; I., Nicoara; A., Lovasz; *Experimental Optimization of Process Parameters in Laser Cutting of Polycarbonate Gears*, Mechanika, no. 2, pp. 233-238, 2012;
- 92.** D. I., Hadaruga; N. G., Hadaruga; G. N., Bandur; H. D., Isengard, *Water Content of Flavonoid/ Cyclodextrin Nanoparticles: Relationship with the Structural Descriptors of Biologically Active Compounds*, Food Chemistry, vol. 132, no. 4, pp. 1651-1659, 2012;
- 93.** N. G., Hadaruga; D. I., Hadaruga; H. D., Isengard; *Water Content of Natural Cyclodextrins and Their Essential Oil Complexes: a Comparative Study Between Karl Fischer Titration and Thermal Methods*, Food Chemistry, vol. 132, no. 4, pp. 1741-1748, 2012;
- 94.** T., Haidegger; L., Kovacs; R. E., Precup; B., Benyo; Z., Benyo; S., Preitl; *Simulation and Control for Telerobots in Space Medicine*, Acta Astronautica, vol. 81, pp. 390-402, 2012;
- 95.** R., Halbac-Cotoara-Zamfir; *The Romanian Banat Region Challenging Climatic Changes*, Journal of Environmental Protection and Ecology, vol. 13, no. 8, pp. 128-134, 2012;
- 96.** I. M., Haragos; C., Cernazanu-Glavan; *Modeling Road Traffic Using Service Centre*, Advances in Electrical and Computer Engineering, vol. 12, no. 2, pp. 75-80, 2012;

- 97.** C., Hedrea; R., Negrea; I., Zaharie; *The $1/2$ Correction Forms in Geometric Quantization of the Symmetric Free Rigid Body*, International Journal of Geometric Methods in Modern Physics, vol. 9, no. 7, 2012;
- 98.** T, Heinosaari; M. A. D., Jivulescu, M., Reeb; M., Wolf; *Extending Quantum Operations*, Journal of Mathematical Physics, vol. 53, no. 10, 2012;
- 99.** I. S., Herban; C., Grecea; C. C., Mușat; *Using a Geographic Information System (Gis) to Model, Manage and Develop Urban Data of the Timișoara City*, Journal of Environmental Protection and Ecology, vol. 13, no. 3, pp. 1616-1624, 2012;
- 100.** I. S., Herban; C.C., Mușat; *Measuring and Determining the Dynamic Deformation of Constructions Using Modern Technologies and Techniques*, Journal of Environmental Protection and Ecology, vol.13, no.2A, pp.1200-1207, 2012;
- 101.** N., Herisanu; V., Marinca; *An Optimal Approach to Study the Nonlinear Behaviour of a Rotating Electrical Machine*, Journal of Applied Mathematics, 2012;
- 102.** N., Herisanu; V., Marinca; *Optimal Homotopy Perturbation Method for a Non-Conservative Dynamical System of a Rotating Electrical Machine*, Zeitschrift fur Naturforschung Section A-A Journal of Physical Sciences, vol. 67, no. 08, pp. 509-516, 2012;
- 103.** I., Hulka; V. A., Serban; I., Secosan; P., Vuoristo; K., Niemi; *Wear Properties of CrC-37WC-18M Coatings Deposited by HVOF and HVAF Spraying Processes*, Surface & Coatings Technology, vol. 210, pp. 15-20, 2012;
- 104.** R., Ianos; R., Lazau; I., Lazau; C., Pacurariu; *Chemical Oxidation of Residual Carbon From ZnAl₂O₄ Powders Prepared by Combustion Synthesis*, Journal of the European Ceramic Society, vol. 32, no. 8, pp. 1605-1611, 2012;
- 105.** R., Ianos; A., Taculescu; C., Pacurariu; I., Lazau; *Solution Combustion Synthesis and Characterization of Magnetite, Fe₃O₄, Nanopowders*, Journal of the American Ceramic Society, vol. 95, no. 7, pp. 2236-2240, 2012;
- 106.** I., Ienciu; L., Dimen; N., Ludusan; C., Grecea; T., Borsan; L., Oprea; *Dynamics of the Rill and Gully Erosion Using Gis Technologies*, Journal of Environmental Protection and Ecology, vol. 13, no. 1, pp. 345-351, 2012;
- 107.** L. I., Iepure; I., Boldea; F., Blaabjerg, I. F.; *Hybrid; Starting and Observer-Based Sensorless Control of Single-Phase BLDC-PM Motor Drives*, IEEE Transactionson Industrial Electronics, vol. 59, no. 9, pp. 3436-3444, 2012;
- 108.** C., Iftode; S., Miclaus; *Design and Validation of a Tem Cell Used for Radiofrequency Dosimetric Studies*, Progress in Electromagnetics Research - PIER, vol. 132, pp. 369-388, 2012;
- 109.** M., Ihos; A., Remes; F., Manea; *Electrochemical Determination of Diclofenac Using Boron-Doped Diamond Electrode*, Journal of Environmental Protection and Ecology, vol. 13, no. 4, pp. 2096-2103, 2012;
- 110.** S., Iliescu; M. G., Augusti; E., Fagadar-Cosma; N., Plesu; G., Fagadar-Cosma; L., Macarie; A., Popa; G., Ilia; *Synthesis of New Phosphorus-Containing (Co) Polyesters Using Solid-Liquid Phase Transfer Catalysis and Product Characterization*, MOLECULES, vol. 17, no. 8, pp. 9090-9103, 2012;
- 111.** G. L., Ioanas; *Modeling, Identification and Prediction of Inherent Quasi-Stationary Pressure Dynamics of a Common-Rail System Using Neuro-Fuzzy Structures With Local Linear arx Models*, Control Engineering and Applied Informatics, vol. 14, no. 3, pp. 61-70, 2012;
- 112.** I., Ionel; M., Dobrin; V., Cebrucean; *Potential of Short Rotation Coppice as Renewable Energy Source. Examples from Romanian Practice*, Journal of Environmental Protection and Ecology, vol. 13, no. 3, pp. 1503-1512, 2012;

- 113.** R., Ionel; G., Vasii; S., Mischie; *GPRS Based Data Acquisition and Analysis System with Mobile Phone Control*, Measurement, vol. 45, no. 6, pp. 1462-1470, 2012;
- 114.** A., Irimescu; *Performance and Fuel Conversion Efficiency of a Spark Ignition Engine Fueled with ISO-Butanol*, Applied Energy, vol. 96, pp. 477-483, 2012;
- 115.** A., Irimescu; D., Iorga; L., Mihon; R., Hentiu; *Emissions Model for Spark Ignition Engines Fuelled with Gasoline-Bioethanol Blends*, Journal of Environmental Protection and Ecology, vol. 13, no. 1, pp. 9-16, 2012;
- 116.** A., Ivan; M., Ivan; V., Precupas; *The Stability Analysis of a Spherical Dome with Arches and Rings*, Metalurgia International, vol. 17, no. 12, pp. 65-72, 2012;
- 117.** C., Ivan; F., Popescu; *Simple Design Equation to Quantify Indoor Air Quality*, Journal of Environmental Protection and Ecology, vol. 13, no. 2, pp. 420-425, 2012;
- 118.** S., Jafarzadeh; C., Lascu; M. S., Fadali; *State Estimation of Induction Motor Drives Using the Unscented Kalman Filter*, IEEE Transactions on Industrial Electronics, vol. 59, no. 11, pp. 4207-4216, 2012;
- 119.** A., Jakab; L. A., Colar; R., Pode; L., Cocheci; F., Manea; *Catalytic Photodegradation and Mineralization of Cationic Dye Methylene Blue from Aqueous Solution onto Copper Doped Zeolite*, Revista de Chimie, vol. 63, no. 10, pp. 1016-1022, 2012;
- 120.** A., Juratoni; F., Pater; O., Bundau; *Operator Representations of Logmodular Algebras Which Admit Gamma-Spectral Rho-Dilations*, Electronic Research Announcements in Mathematical Sciences, vol. 19, pp. 49-57, 2012;
- 121.** A., Kellenberger; E., Dmitrieva; I., Dunsch; *Structure Dependence of Charged States in "Linear" Polyaniline as Studied by in Situ ATR-FTIR Spectroelectrochemistry*, Journal of physical chemistry b, vol. 116, no. 14, pp. 4377-4385, 2012;
- 122.** I. Kiss; *Investigations Upon the Indefinite Rolls Quality Assurance in Multiple Regression Analysis*, Revista de Metalurgia, vol. 48, no. 2, pp. 85-96, 2012;
- 123.** A. S. R., Kuramoto; F., Ciriaco; T., Abrao; P.J.E., Jeszensky; *Sequence Design for MPG QS-CDMA Systems Based on Heuristic Combinatorial Optimization*, Wireless Communications & Mobile Computing, vol. 12, no. 3, pp. 236-247, 2012;
- 124.** R. C., Laslau; A., Nichici; *Factors Affecting the Energy Consumption in Pulsed ND:Yag Laser Cutting of Glass Fiber/Epoxy Composite*, Materiale Plastice, vol. 49, no. 4, pp. 260-265, 2012;
- 125.** I. C., Lazar, *Discrete Morse Theory, Simplicial Nonpositive Curvature, and Simplicial Collapsibility*, Balkan Journal of Geometry and Its Applications, vol. 17, no. 1, pp. 58-69, 2012;
- 126.** I., Lazau; C., Vancea, *Foam Glass as an Alternative for Glass Wastes Recycling*, Revista Romana de Materiale-Romanian Journal of Materials, vol. 42, no. 3, pp. 270-275, 2012;
- 127.** C., Lazureanu; T., Binzar, *On the Symmetries of a Rikitake Type System*, Comptes Rendus Mathematique, vol. 350, no.09, pp. 529-533, 2012;
- 128.** C., Lazureanu; T., Binzar, *On a Hamiltonian Version of Controls Dynamic for a Drift-Free Left Invariant Control System on G(4)*, International Journal of Geometric Methods in Modern Physics, vol. 9, no. 8, 2012;
- 129.** C., Lazureanu; T., Binzar, *A Rikitake Type System with Quadratic C Control*, International Journal of Bifurcation and Chaos, vol. 22, no. 11, 2012;

- 130.** D., Lelea, *The Tangential Micro-Heat Sink with Multiple Fluid Inlets*, International Communications in Heat and Mass Transfer, vol. 39, no. 2, pp. 190-195, 2012;
- 131.** I., Luminosu; A., De Sabata; C., De Sabata; T., Jurca, *Solar Collectors from Recyclable Materials*, Journal of Environmental Protection and Ecology, vol. 13, no. 1, pp. 300-306, 2012;
- 132.** I., Luminosu; L., Fara; N., Pop; M., Costache; S., Far, *Exergy Analysis of the Air Solar Collector Based on Experimental Data*, Environmental Engineering and Management Journal, vol. 11, no. 8, pp. 1367-1374, 2012;
- 133.** C. A., Macarie; A. E., Segneanu; I., Balcu; R., Pop; G., Burtica; M., Ungurean; I., Grozescu, *Use of Alkaline Lyophilization Process for Lignocellulosic Biomass Pretreatment*, Digest Journal of Nanomaterials and Biostructures, vol. 7, no. 4, pp. 1577-1586, 2012;
- 134.** F., Manea; S., Motoc; A., Pop; A., Remes; J., Schoonman, *Silver-functionalized Carbon Nanofiber Composite Electrodes for Ibuprofen Detection*, Nanoscale Research Letters, vol. 7, 2012;
- 135.** M., Manole; C., Sinescu; C. A., Dughir; A., De Sabata; M. L., Negrutiu; C., Bratu; L., Ardelean; L. C., Rusu; S., Stratul; M., Rominu; D., Dudea, *Holographic Methods for the Evaluation of Gingival Margins Retractions*, Revista de Chimie, vol. 63, no. 6, pp. 626-628, 2012;
- 136.** G., Marginean; D., Utu, *Cyclic Oxidation Behaviour of Different Treated Conicraly Coatings*, Applied Surface Science, vol. 258, no. 20, pp. 8307-8311, 2012;
- 137.** V., Marinca; N., Herisanu, *An Optimal Iteration Method for Strongly Nonlinear Oscillators*, Journal of Applied Mathematics, 2012;
- 138.** V., Marinca; N., Herisanu, *Optimal Parametric Iteration Method for Solding Multispecies Lotka-Volterra Equation*, Discrete Dinamics in Nature Acold Societz, 2012.
- 139.** S., Masu; L. N., Jurj, *Studies to Limit Bioaccumulation of Heavy Metals in Biomass Grownon Lignite Fly Ash Deposits*, Revista de Chimie, vol. 63, no. 12, pp. 1306-1311, 2012;
- 140.** M. C., Matei; C. S., Nes, *Extensive Use of the Railway System-an Efficient Way of Reducing CO2 Emissions in the Transportation Sector*, Journal of Environmental Protection and Ecology, vol. 13, no. 2A, pp. 844-851, 2012;
- 141.** C. A., Mazilescu; S., Abdellaoui; B., Gangloff, *Assessing the Social Value of Personality Information*, Revista de Cercetare și Intervenție Socială, vol. 38, pp. 91-106, 2012;
- 142.** M., Miclău; D., Ursu; S., Kumar; I., Grozescu, *Hexagonal Polytype of CuCrO₂ Nanocrystals Obtained by Hydrothermal Method*, Journal of Nanoparticle Research, vol. 14, no. 9, 2012;
- 143.** N., Minculete; C., Pozna; R. E., Precup, *A Refinement of Sandor-Tth's Inequality*, Journal of Inequalities and Applications, 2012;
- 144.** I., Miron; C., Enache; A., Dabici; I., Grozescu, *Characterization and Luminescence Properties of ZnAl₂O₄:Tb³⁺ (2.5%) Phosphor*, Journal of Optoelectronics and Advanced Materials, vol. 14, no. 9, pp. 820-825, 2012;
- 145.** I., Miron; C., Enache; I., Grozescu, *Doped Zinc Aluminate Spinel Synthesized by Hydrothermal Method*, Digest Journal of Nanomaterials and Biostructures, vol. 7, no. 3, pp. 967-972, 2012;
- 146.** I., Miron; C., Enache; M., Vasile; I., Grozescu, *Optical Properties of ZnAl₂O₄ Nanomaterials Obtained by the Hydrothermal Method*, Physica scripta, vol. T149, 2012;
- 147.** I., Miron; I., Grozescu, *Cobalt-Doped Gahnite Synthesized by Hydrothermal Method*, Optoelectronics and Advanced Materials-Rapid Communications, vol. 6, no. 9, pp. 931-934, 2012;

- 148.** I., Miron; I., Grozescu, *Hydrothermal Synthesis of ZnAl₂O₄: Cr³⁺ Nanocrystals*, Optoelectronics and Advanced Materials-Rapid Communications, vol. 6, no. 9, pp. 673-675, 2012;
- 149.** I., Miron; D. H., Ursu; M., Miclau; I., Grozescu, *Sn/SiO₂ Single Crystals Growth by the Hydrothermal Method at High Temperatures and Pressures*, Physica scripta, vol. T149, 2012;
- 150.** G., Mircea; M., Neamtu; O., Bundau; D., Opris, *Uncertain and Stochastic Financial Models with Multiple Delays*, International Journal of Bifurcation and Chaos, vol. 22, no. 26, 2012;
- 151.** M., Mirea; C. O., Voicu, *Aspects Concerning the Use of the Geosynthetics in Settling Ponds*, Metalurgia International, vol. 17, no. 3, pp. 44-46, 2012;
- 152.** R., Mirsu; S., Micut; C., Căleanu; D. B., Mirsu, *Optimized Simulation Framework for Spiking Neural Networks Using Gpu's*, Advances in Electrical and Computer Engineering, vol. 12, no. 23, pp. 61-68, 2012;
- 153.** I., Mitelea; V., Budau; C., Craciunescu, *Dissimilar Friction Welding of Induction Surface-Hardened Steels and Thermochemically Treated Steels*, Journal of Materials Processing Technology, vol. 212, no. 9, pp. 1892-1899, 2012;
- 154.** G. E., Mocuta, *Noise Pollution Emitted as a Consequence of the Urban Transport Development*, Journal of Environmental Protection and Ecology, vol. 13, no. 2A, pp. 852-861, 2012;
- 155.** G. A., Mosoarca; A., Negrea, *Studies Regarding the Effects of Settling Tanks Sludge Recycling on Organic Matter Concentration from Treated Water*, Journal of Environmental Protection and Ecology, vol. 13, no. 1, pp. 198-202, 2012;
- 156.** S., Motoc; F., Manea; A., Pop; R., Pode; C., Teodosiu, *Electrochemical Degradation of Pharmaceutical Effluents on Carbon-Based Electrodes*, Environmental Engineering and Management Journal, vol. 11, no. 3, pp. 627-634, 2012;
- 157.** P. S., Murvay; I., Silea, *A Survey on Gas Leak Detection and Localization Techniques*, Journal of Loss Prevention in the Process Industries, vol. 25, no. 6, pp. 966-973, 2012;
- 158.** C. C., Musat; I. S., Herban, *Study on Reverse Engineering of Historical Architecture in Timișoara Based on 3D Laser Point Technologies*, Journal of Environmental Protection and Ecology, vol. 13, no. 2A, pp. 1107-1116, 2012;
- 159.** M., Nagi; I. D., Carabas; P., Ilies; E., Ghita, *Experimental Determination of Exploitation Feature and Efficiency of Compact Heat Exchangers with Wavy Fins*, Journal of Environmental Protection and Ecology, vol. 13, no. 2A, pp. 1942-1947, 2012;
- 160.** T., Nagy-Gyorgy; G., Sas; A. C., Daescu; J. A. O., Barros; V., Stoian, *Experimental and Numerical Assessment of the Effectiveness of FRP-Based Strengthening Configurations for Dapped-End RC Beams*, Engineering Structures, vol. 44, pp. 291-303, 2012;
- 161.** A., Negoitescu; A., Tokar, *Water Disinfection and the Implementation of Modern Technologies at Potable Water Treatment Station*, Revista de Chimie, vol. 63, no. 10, pp. 1079-1083, 2012;
- 162.** G. C., Nisulescu; I., Ionel; B., Malan; M., Dobrin, *Remote SO₂ Monitoring with UV Cameras for Stack Emissions*, Revista de Chimie, vol. 63, no. 9, pp. 940-944, 2012;
- 163.** G. C., Nisulescu; I., Ionel; F., Popescu, *Research Concerning Emissions Monitoring by Means of Uv Cameras*, Optoelectronics and Advanced Materials-Rapid Communications, vol. 6, no. 9, pp. 935-940, 2012;

- 164.** S., Novaconi; R., Banica; N., Vaszilcsin, *Influence of Hydrochloric Acid on Response Time and Photoelectric Performance of Dye-Sensitized Solar Cells Under Chopping Light*, Optoelectronics and Advanced Materials-Rapid Communications, vol. 6, no. 11, pp. 1185-1188, 2012;
- 165.** N. V., Olarescu; S., Musuroi; C., Sorandaru; F. M., Frigura-Iliasa, *Scalar Control Systems with Permanent Magnet Synchronous Motors with Sinusoidal Current Control. Calculation of Speed Controller Parameters*, Revue Roumaine Des Sciences Techniques-Serie Electrotechnique Et Energetique, vol. 57, no. 1, pp. 70-79, 2012;
- 166.** C., Orha; A., Pop; C., Lazau; L., Grozescu; V., Tiponut; F., Manea, *Silver Doped Natural and Synthetic Zeolites for Removal of Humic Acid from Water*, Environmental Engineering and Management Journal, vol. 11, no. 3, pp. 641-649, 2012;
- 167.** G., Padure; A., Irimescu; L., Calin; G., Trif-Tordai; A. E., Cioabla; I., Vetres, *Theoretical Study of Emissions for Stationary Spark Ignition Engines Fuelled with Biogas*, Journal of Environmental Protection and Ecology, vol. 13, no. 2A, pp. 1047-1052, 2012;
- 168.** G., Padure; A., Irimescu; L., Calin; G., Trif-Tordai; A. E., Cioabla; I., Vetres, *Initial Theoretical Development of an Isobutanol-Methane Dual Fuel System for a Spark Ignition Engine*, Journal of Environmental Protection and Ecology, vol. 13, no. 2A, pp. 1053-1060, 2012;
- 169.** A. M., Pana; V., Gherman; P., Sfirloaga; G., Bandur; L. M., Stefan; M., Popa; L. M., Rusnac, *Thermal Stability and Biodegradation of Novel D-mannose Based Glycopolymers*, Polymer Testing, vol. 31, no. 3, pp. 384-392, 2012;
- 170.** P., Papaphilippou; M., Christodoulou; O. M., Marinica; A., Taculescu; L., Vekas; K., Chrissafis; T., Krasia-Christoforou, *Multiresponsive Polymer Conetworks Capable of Responding to Changes in pH, Temperature, and Magnetic Field: Synthesis, Characterization and Evaluation of Their Ability for Controlled Uptake and Release of Solutes*, ACS Applied Materials & Interfaces, vol. 4, no. 4, pp. 2139-2147, 2012;
- 171.** M. C., Pascariu; L. M., Rusnac; A. M., Macsim, *Tethered Glycoderivatives with Unsaturated Spacer: Synthesis and Characterization*, Synthetic Communications, vol. 42, no. 17, pp. 2503-2511, 2012;
- 172.** E., Paulescu; N., Stefu; P., Gravila; R. S., Boata; N., Pop; M., Paulescu, *Procedure of Embedding Biological Action Functions Into the Atmospheric Transmittance*, Theoretical and Applied Climatology, vol. 109, no. 3, pp. 323-332, 2012;
- 173.** C., Păcurariu; I., Lazau, *Non-Isothermal Crystallization Kinetics of Some Glass-Ceramics with Pyroxene Structure*, Journal of Non-Crystalline Solids, vol. 358, no. 54, pp. 3332-3337, 2012;
- 174.** C. A., Pepa, *Assessment of the Water Framework Directive Implementation in Romania: Case Study of Bega Catchment*, Environmental Engineering and Management Journal, vol. 11, no. 5, pp. 945-952, 2012;
- 175.** V. E., Petrova; L., Marsavina; T., Sadowski, *Revisit of Compact Mode II Crack Specimen: Analysis and Fracture Interpretation*, Theoretical and Applied Fracture Mechanics, vol. 59, no. 1, pp. 41-48, 2012;
- 176.** C., Pompermaier; K. F. R., Haddad; A., Zambonetti; M. V. R., Da Luz; I., Boldea, *Small Linear Pm Oscillatory Motor: Magnetic Circuit Modeling Corrected by Axisymmetric 2-D Fem and Experimental Characterization*, IEEE Transactions on Industrial Electronics, vol. 59, no. 3, pp. 1389-1396, 2012;
- 177.** A., Pop; F., Manea; C., Orha; S., Motoc; E., Ilinoiu; N., Vaszilcsin; J., Schoonman, *Copper-Decorated Carbon Nanotubes-Based Composite Electrodes for Nonenzymatic Detection of Glucose*, Nanoscale Research Letters, vol. 7, pp. 266, 2012;

- 178.** A., Pop; F., Manea; C., Radovan; D., Dascalu; N., Vaszilcsin; J., Schoonman, *Non-Enzymatic Electrochemical Detection of Glycerol on Boron-Doped Diamond Electrode*, *Analyst*, vol. 137, no. 3, pp. 641-647, 2012;
- 179.** R., Pop; M. N., Stefanut; A., Cata; C., Tanasie; M., Medeleanu, *Ab Initio Study Regarding the Evaluation of the Antioxidant Character of Cyanidin, Delphinidin and Malvidin*, *Central European Journal of Chemistry*, vol. 10, no. 1, pp. 180-186, 2012;
- 180.** M., Popa; M., Glevitzky; D., Popa; S., Varvara; G. A., Dumitrel, *Study on Soil Pollution with Heavy Metals Near the River Ampoi, the Alba County*, *Journal of Environmental Protection and Ecology*, vol. 13, no. 4, pp. 2123-2129, 2012;
- 181.** M., Popescu; G. E., Mocuta; A., Raduta; A., Magda, *Safely Cmt Welding Case Study*, *Journal of Environmental Protection and Ecology*, vol. 13, no. 2A, pp. 1038-1046, 2012;
- 182.** D. M., Poyatos; R., Carbonell; I., Palomeras; J. F., Simancas; P., Ayarza; D., Marti; A., Azor; A., Jabaloy; P. G., Cuadra; R., Tejero; L. M. M., Parra; J., Matas; F. G., Lodeiro; A., Perez-Estaun; J. L. G., Lobon; L., Mansilla, *Imaging the Crustal Structure of the Central Iberian Zone (Variscan Belt) the Alcudia Deep Seismic Reflection Transect*, *Tectonics*, vol. 31, 2012;
- 183.** C., Pozna; N., Minculete; R. E., Precup; L. T., Koczy; A., Ballagi, *Signatures: Definitions, Operators and Applications to Fuzzy Modelling*, *Fuzzy Sets and Systems*, vol. 2012, pp. 86-104, 2012;
- 184.** C., Pozna; R. E., Precup, *Aspects Concerning the Observation Process Modelling in the Framework of Cognition Processes*, *Acta Polytechnica Hungarica*, vol. 9, no. 1, pp. 203-223, 2012;
- 185.** R. E., Precup; R. C., David; E. M., Petriu; S., Preitl; M. B., Radac, *Fuzzy Control Systems with Reduced Parametric Sensitivity Based on Simulated Annealing*, *IEEE Transactionson Industrial Electronics*, vol. 59, no. 8, pp. 3049-3061, 2012;
- 186.** R. E., Precup; R. C., David; E. M., Petriu; S., Preitl; M. B., Radac, *Novel Adaptive Gravitational Search Algorithm for Fuzzy Controlled Servo Systems*, *IEEE Transactionson Industrial Informatics*, vol. 8, no. 4, pp. 791-800, 2012;
- 187.** R. E., Precup; C. A., Dragos; S., Preitl; M. B., Radac; E. M., Petriu, *Novel Tensor Product Models for Automatic Transmission System Control*, *IEEE Systems Journal*, vol. 6, no. 3, pp. 488-498, 2012;
- 188.** R. E., Precup; T., Haidegger; S., Preitl; Z., Benyo; A. S., Paul; L., Kovacs, *Fuzzy Control Solution for Telesurgical Applications*, *Applied and Computational Mathematics*, vol. 11, no. 3, pp. 378-397, 2012;
- 189.** R. E., Precup; M. L., Tomescu; E. M., Petriu; S., Preitl; C. A., Dragos, *Stable Design of a Class of Nonlinear Discrete-Time Mimo Fuzzy Control Systems*, *Acta Polytechnica Hungarica*, vol. 9, no. 2, pp. 57-76, 2012;
- 190.** R. E., Precup; M. L., Tomescu; M. B., Radac; E. M., Petriu; S., Preitl; C. A., Dragos, *Iterative Performance Improvement of Fuzzy Control Systems for Three Tank Systems*, *Expert Systems with Applications*, vol. 39, no. 9, pp. 8288-8299, 2012;
- 191.** F., Prutianu; V., Popescu; D., Lascu, *Automated Testing System for a Can Communication Circuit*, *Advances in Electrical and Computer Engineering*, vol. 12, no. 2, pp. 69-74, 2012;
- 192.** R., Radoslav; A. M., Branea; B., Demetrescu, *Resolving Ecological Problems Through a Holistic Vision of Regional Urban Planning*, *Journal of Environmental Protection and Ecology*, vol. 13, no. 4, pp. 2249-2256, 2012;

- 193.** A., Remes; A., Pop; F., Manea; A., Baci; S. J., Picken; J., Schoonman, *Electrochemical Determination of Pentachlorophenol in Water on a Multi-Wall Carbon Nanotubes-Epoxy Composite Electrode*, *Sensors*, vol. 12, no. 6, pp. 7033-7046, 2012;
- 194.** A., Riel; A., Draghici; G., Draghici; D., Grajewski; R., Messnarz, *Process and Product Innovation Needs Integrated Engineering Collaboration Skills*, *Journal of Software-Evolution and Process*, vol. 24, no. 5, pp. 551-560, 2012;
- 195.** A., Ravis; N. G., Hadaruga; Z., Garban; D. I., Hadaruga, *Titanocene/Cyclodextrin Supramolecular Systems: a Theoretical Approach*, *Chemistry Central Journal*, vol. 6., 2012;
- 196.** A., Robu; R., Aldea; O., Munteanu; M., Neagu; L., Stoicu-Tivadar; A., Neagu, *Computer Simulations of in Vitro Morphogenesis*, *Biosystems*, vol. 109, no. 3, pp. 430-443, 2012;
- 197.** C. A., Rosca; G. E., Mocuta; M. I., Popescu., I., Ionel; D. S., Stepan; M., Matei, *Sustainable Development of Transport in the West Region of Romania*, *Journal of Environmental Protection and Ecology*, vol. 13, no. 1, pp. 227-235, 2012;
- 198.** R. A., Rosu; I., Bran; M., Popescu; C., Opris, *In Vitro Characterization of Hydroxyapatite Layers Deposited by APS and Hvf of Thermal Spraying Methods*, *Ceramics-Silikaty*, vol. 56, no. 1, pp. 25-31, 2012;
- 199.** R. A., Rosu; V. A., Serban; A. I., Bucur; U., Dragos, *Deposition of Titanium Nitride and Hydroxyapatite-Based Biocompatible Composite by Reactive Plasma Spraying*, *Applied Surface Science*, vol. 258, no. 8, pp. 3871-3876, 2012;
- 200.** S. F., Rus; P., Vlazan; S., Novaconi; P., Sfirloaga; I., Grozescu, *Synthesis and Characterization CuFe2O4 Nanoparticles Prepared by the Hydrothermal Ultrasonic Assisted Method*, *Journal of Optoelectronics and Advanced Materials*, vol. 14, no. 3, pp. 293-297, 2012;
- 201.** C., Saceanu; R. A., Rosu; D. R., Pascu, *Endurance Evaluation of the Deposited Layers on the Coal Hammers Mills*, *Metalurgia International*, vol. 17, no. 5, pp. 53-58, 2012;
- 202.** C., Saceanu; R. A., Rosu; D. R., Pascu, *Experimental Research Regarding Galvanized Steel Welding by CMT Method*, *Metalurgia International*, vol. 17, no. 1, pp. 33-37, 2012;
- 203.** V. I., Safta, *Global Influence of Constructive and Functional Factors on the Mechanical Characteristics of S235n Steel*, *Metalurgia International*, vol. 17, no. 4, pp. 169-174, 2012;
- 204.** V., Sajfert; N., Pop; M., Duric; D., Popov; C., Hatiegan, *About Some Thermodynamical Properties of Cylindrical Nanorods*, *Romanian Reports in Physics*, vol. 64, no. 4, pp. 1019-1027, 2012;
- 205.** I., Savva; G., Krekos; A., Taculescu; O., Marinica; L., Vekas; T., Krasia-Christoforou, *Fabrication and Characterization of Magnetoresponse Electrospun Nanocomposite Membranes Based on Methacrylic Random Copolymers and Magnetite Nanoparticles*, *Journal of Nanomaterials*, 2012;
- 206.** I. F., Schneider; N., Pop; C., Jungen; *Analytic Three-Channel Model for Resonance-Averaged Direct and Indirect Dissociative Recombination Processes of Molecular Ions*, *Physical Review*, vol. 86, no. 6, 2012;
- 207.** A. E., Segneanu; M., Milea; I., Grozescu, *New Series of Asymmetrical Carbonates Used in Peptide Synthesis*, *Optoelectronics and Advanced Materials-Rapid Communications*, vol. 6, no. 5, pp. 656-659, 2012;
- 208.** V. A., Serban; D., Utu; I., Hulka; C., Opris, *Sliding Wear Behavior of Different Hvf Sprayed Cermet Coatings*, *Optoelectronics and Advanced Materials-Rapid Communications*, vol. 6, no. 7, pp. 746-749, 2012;

- 209.** E., Simion; L., Mihalcea; F., Simion; C., Pacurar, *Evaluation Model of Atmospheric Natural Radioactivity Considering Meteorological Variables*, Revista de Chimie, vol. 63, no. 12, pp. 1251-1256, 2012;
- 210.** C., Sinescu; L., Marsavina; A., Cernescu, *Asymptotic Stress Field for the Interface Between Teeth and Different Restorative Materials*, Computational Materials Science, vol. 59, pp. 57-64, 2012;
- 211.** C., Sinescu; L., Marsavina; M. L., Negrutiu; L. C., Rusu; L., Ardelean; M., Rominu; I., Antoniac; F. I., Topala; C. E., Podoleanu, *New Metallic Nanoparticles Modified Adhesive Used for Time Domain Optical Coherence Tomography Evaluation of Class II Direct Composite Restoration*, Revista de Chimie, vol. 63, no. 4, pp. 380-383, 2012;
- 212.** N., St Lontis; I., Ionel; F., Popescu; F., Iacobescu, *Biofuels Fired in Small-Scale Cogeneration. a New Potential in Greenhouse Gases Reduction*, Journal of Environmental Protection and Ecology, vol. 13, no. 3, pp. 1497-1502, 2012;
- 213.** I. R., Stanciu; G., Ginga; S., Muntean; L. E., Anton, *Low-Speed-Small-Load Direct Torque Control Ripples Filtering*, Proceedings of the Romanian Academy Series a-Mathematics Physics Technical Sciences Information Science, vol. 13, no. 2, pp. 125-132, 2012;
- 214.** I. R., Stanciu; F., Molnar-Matei, *Detecting Power Voltage Dips Using Tracking Filters-A Comparison Against Kalman*, Advances in Electrical and Computer Engineering, vol. 12, no. 4, pp. 77-82, 2012;
- 215.** O., Stefanescu; M., Stoia Barbu; M., Stefanescu, *Organic-Inorganic Hybrid Gels of Diol-Teos Type. Synthesis and Study on the Chemical Interaction*, Acta Chimica Slovenica, vol. 59, no. 2, pp. 281-288, 2012;
- 216.** L., Stelea; I., Costescu, *Ecologically Sustainable Asphalt Mixtures in the Road Technique*, Journal of Environmental Protection and Ecology, vol. 13, no. 4, pp. 2325-2330, 2012;
- 217.** D., Stepan; I., Ionel; W., Stefanescu; L. I., Dungan, *Noise Control in Railway Vehicles*, Journal of Environmental Protection and Ecology, vol. 13, no. 2, pp. 561-570, 2012;
- 218.** A., Stirban; I., Boldea; G. D., Andreescu, *Motion-Sensorless Control of BLDC-PM Motor with Offline FEM-Information-Assisted Position and Speed Observer*, IEEE Transactions on Industry Applications, vol. 48, no. 6, pp. 1950-1958, 2012;
- 219.** M. Stoia; M., Barbu; M., Stefanescu; P., Barvinschi; L., Barbu-Tudoran, *Synthesis of Nanosized Zinc and Magnesium Chromites Starting from PVA-Metal Nitrate Solutions*, Journal of Thermal Analysis and Calorimetry, vol. 110, no. 1, pp. 85-92, 2012;
- 220.** M. Stoia; P., Barvinschi; L. B., Tudoran; M., Barbu; M., Stefanescu, *Synthesis of Nanocrystalline Nickel Ferrite by Thermal Decomposition of Organic Precursors*, Journal of Thermal Analysis and Calorimetry, vol. 108, no. 3, pp. 1033-1039, 2012;
- 221.** M. Stoia; M., Stefanescu; M., Barbu; P., Barvinschi; L., Barbu-Tudoran, *Studies Regarding the Formation from Metal Nitrates and Diol of (NiM₂O₄)-O-III Spinels, Inside a Silica Matrix*, Journal of Thermal Analysis and Calorimetry, vol. 108, no. 3, pp. 1041-1049, 2012;
- 222.** F. D., Stoian; S., Holotescu, *Experimental Study of Natural Convection Enhancement Using a Fe₃O₄-Water Based Magnetic Nanofluid*, Journal of Nanoscience and Nanotechnology, vol. 12, no. 10, pp. 8211-8214, 2012;
- 223.** D., Stoica; M., Megan, *On Nonuniform Dichotomy for Stochastic Skew-Evolution Semiflows in Hilbert Spaces*, Czechoslovak Mathematical Journal, vol. 62, no. 4, pp. 879-887, 2012;

- 224.** M., Sturza, *Effective Management of Spatial Data in Order to Achieve Urban Planning*, Journal of Environmental Protection and Ecology, vol. 13, no. 3A, pp. 1974-1981, 2012;
- 225.** M., Sturza, *Influence of Deformations in Selecting Cartographic Projections Necessary for Drawing Maps Used in Applications of Environmental Engineering Field*, Journal of Environmental Protection and Ecology, vol. 13, no. 2A, pp. 1192-1199, 2012;
- 226.** M., Suba; I., Lazau; C., Pacurariu, *Behaviour of Alkaline-Earth Metal Nitrate - Fuel Binary Mixtures in Solution Combustion Synthesis*, Environmental Engineering and Management Journal, vol. 11, no. 3, pp. 661-667, 2012;
- 227.** D., Susan-Resiga; V., Socoliuc; T., Boros; T., Borbath; O., Marinica; A., Han; L., Vekas, *The Influence of Particle Clustering on the Rheological Properties of Highly Concentrated Magnetic Nanofluids*, Journal of Colloid and Interface Science, vol. 373, pp. 110-115, 2012;
- 228.** L. M., Suta; L., Vlaia; V., Vlaia; I., Olariu; D. L., Hadaruga; C., Mircioiu, *Study of the Complexation Behavior of Tenoxicam with Cyclodextrins*, Farmacia, vol. 60, no. 4, pp. 475-483, 2012;
- 229.** I., Tatai; I., Zaharie, *The Energy Transfer Between the Ports of an Implemented Gyrator Using Lm13700 Operational Transconductance Amplifier*, Review of Scientific Instruments, vol. 83, no. 11, 2012;
- 230.** M., Tilneac; V., Dolga; S., Grigorescu; M. A., Bitea, *3D Stereo Vision Measurements for Weed-Crop Discrimination*, Elektronika IR Elektrotehnika, vol., no. 7, pp. 9-12, 2012;
- 231.** M., Timko; K., Marton; L., Tomco; J., Kiraly; M., Molcan; M., Rajnak; P., Kopcansky; C., Cimbala; F., Stoian; S., Holotescu; A., Taculescu, *Magneto-Dielectric Properties of Transformer Oil Based Magnetic Fluids in the Frequency Range UP TO 2 MHz*, Magnetohydrodynamics, vol. 48, no. 2, pp. 427-434, 2012;
- 232.** A., Tokar; A., Negoitescu, *Researches on the Chemical Indicators of Discharged Water, Treated by Mechano-Biological Methods*, Revista de Chimie, vol. 63, no. 11, pp. 1181-1186, 2012;
- 233.** C. E., Tomescu; M., Dobrin; I., Ionel, *Critical Analysis of the Main Advanced Post-Combustion CO₂ Capture Technologies Applied in Industrial Power Plants Running on Fossil Fuels*, Revista de Chimie, vol. 63, no. 8, pp. 792-796, 2012;
- 234.** G. I., Trif-Tordai; I., Ionel; A., Cioabla; D., Cebrucean; F., Popescu, *Comparative Results Concerning CO-Firing of Biomass Residues with Pit Coal in a Pilot Plant*, Journal of Environmental Protection and Ecology, vol. 13, no. 2, pp. 700-709, 2012;
- 235.** R. M., Tudoran; A., Girban; *On the Completely Integrable Case of the Rossler System*, Journal of Mathematical Physics, vol. 53, no. 5, 2012;
- 236.** R. M., Tudoran; A., Girban, *On a Hamiltonian Version of a Three-Dimensional Lotka-Volterra System*, Nonlinear Analysis-Real World Applications, vol. 13, no. 5, pp. 2304-2312, 2012;
- 237.** M., Udrescu; L., Prodan; M., Vladutiu, *Simulated Fault Injection Methodology for Gate-Level Quantum Circuit Reliability Assessment*, Simulation Modelling Practice and Theory, vol. 23, no. 28, pp. 60-70, 2012;
- 238.** A., Ursoiu; C., Paul; T., Kurtan; F., Peter, *Sol-Gel Entrapped Candida Antarctica Lipase B - A Biocatalyst with Excellent Stability for Kinetic Resolution of Secondary Alcohols*, Molecules, vol. 17, no. 1, pp. 13045-13061, 2012;

- 239.** C. C., Vaduva; N., Vaszilcsin; A., Kellenberger, *Aromatic Amines as Proton Carriers for Catalytic Enhancement of Hydrogen Evolution Reaction on Copper in Acid Solutions*, International Journal of Hydrogen Energy, vol. 37, no. 17, pp. 12089-12096, 2012;
- 240.** C. C., Vaduva; N., Vaszilcsin; A., Kellenberger; M., Medeleanu, *Inhibition Effect of Some Aromatic Amines on Copper Electrodeposition from Acidic Baths*, Journal of Applied Electrochemistry, vol. 42, no. 4, pp. 217-224, 2012;
- 241.** N., Vaszilcsin; V., Ordodi; A., Borza, *Corrosion Inhibitors from Expired Drugs*, International Journal of Pharmaceutics, vol. 431, no. 1, pp. 241-244, 2012;
- 242.** I., Vetres; I., Ionel; M. M., Cazacu; I., Balin, *Necessity of Complementary Vertically-Resolved Lidar Observation for Ground Air Pollution Analysis in Western Romania*, Journal of Environmental Protection and Ecology, vol. 13, no. 2, pp. 409-419, 2012;
- 243.** A., Visa; M., Mracec; B., Maranescu; V., Maranescu; G., Ilia; A., Popa; M., Mracec; *Structure Simulation Into a Lamellar Supramolecular Network and Calculation of the Metal Ions/Ligands Ratio*, Chemistry Central Journal, vol. 6, 2012;
- 244.** P., Vlazan; M., Stefanescu; P., Barvinschi; M. Stoia, *Study on the Formation of $\text{CoFe}_3\text{-XO}_4$ System Using Two Low Temperature Synthesis Methods*, Materials Research Bulletin, vol. 47, no. 12, pp. 4119-4125, 2012;
- 245.** M., Voinescu; D. P., Soares; R. M. N., Jorge; A., Davidescu; L. J., Machado, *Estimation of the Forces Generated by the Thigh Muscles for Transtibial Amputee Gait*, Journal of Biomechanics, vol. 45, no. 6, pp. 972-977, 2012;
- 246.** R., Zaharia; J. M., Franssen, *Simple Equations for the Calculation of the Temperature within the Cross-Section of Slim Floor Beams Under is Fire*, Steel and Composite Structures, vol. 13, no. 2, pp. 171-185, 2012.



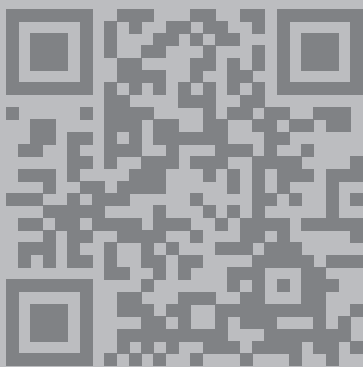

**Universitatea
Politehnica din
Timișoara**

Piața Victoriei Nr. 2
RO - 300006, Timișoara
Tel: +40 256 40 30 00
Fax: +40 256 40 30 21
rector@rektorat.upt.ro



EDITURA POLITEHNICA

www.upt.ro

ISSN 1841-2769